



Article scientifique

Article

2021

Accepted version

Public access

This is an author manuscript post-peer-reviewing (accepted version) of the original publication. The layout of the published version may differ .

---

## Interactional effects between relational and cognitive reserves on decline in executive functioning

---

Sauter, Julia; Widmer, Eric; Baeriswyl, Marie; Ballhausen, Nicola; Vallet, Fanny; Fagot, Delphine;  
Kliegel, Matthias; Ihle, Andreas

### How to cite

SAUTER, Julia et al. Interactional effects between relational and cognitive reserves on decline in executive functioning. In: Journals of Gerontology. B, Psychological Sciences & Social Sciences, 2021, vol. 76, n° 8, p. 1523–1532. doi: 10.1093/geronb/gbaa054

This publication URL: <https://archive-ouverte.unige.ch/unige:144912>

Publication DOI: [10.1093/geronb/gbaa054](https://doi.org/10.1093/geronb/gbaa054)

© This document is protected by copyright. Please refer to copyright holder(s) for terms of use.

Last deposit update in Archive ouverte UNIGE on 16.03.2023 00:23

## **Interactional effects between relational and cognitive reserves on decline in executive functioning**

Julia Sauter<sup>1, 2</sup>, MA

Eric Widmer<sup>2, 3</sup>, PhD

Marie Baeriswyl<sup>1, 2</sup>, PhD

Nicola Ballhausen<sup>1, 2</sup>, PhD

Fanny Vallet<sup>1, 2, 5</sup>, PhD

Delphine Fagot<sup>1, 2, 4</sup>, PhD

Matthias Kliegel<sup>1, 2, 4</sup>, PhD

Andreas Ihle<sup>1, 2, 4</sup>, PhD

<sup>1</sup> Centre for the Interdisciplinary Study of Gerontology and Vulnerability, University of Geneva, Geneva, Switzerland

<sup>2</sup> Swiss National Centre of Competence in Research LIVES – Overcoming vulnerability: Life course perspectives, Lausanne and Geneva, Switzerland

<sup>3</sup> Department of Sociology, University of Geneva, Geneva, Switzerland

<sup>4</sup> Department of Psychology, University of Geneva, Geneva, Switzerland

<sup>5</sup> Groupe de Recherche en Psychologie de la Santé, University of Geneva, Geneva, Switzerland

Correspondence:

Julia Sauter, CIGEV, University of Geneva,

Boulevard du Pont d'Arve 28, 1205 Geneva, Switzerland.

E-mail: Julia.Sauter@unige.ch

Phone: +41 22 37 93764

Word count main text: 4957; Number of references: 50; Number of data elements: 4

## Abstract

*Objectives:* The present study set out to investigate associations of cognitive reserve (as indicated by education) and relational reserve (as indicated by the family network size and indices of emotional support) to decline in executive functioning over six years as measured by changes in Trail Making Test (TMT) completion time in older adults and whether education and network size interacted with age and sex as covariates with respect to this longitudinal association.

*Method:* We analyzed data from 897 participants tested on TMT parts A and B in two waves six years apart. Mean age in the first wave was 74.33 years. Participants reported information on their family networks and their level of education.

*Results:* Latent change score modeling testing for moderation effects revealed a significant interaction of network size in the first wave of data assessment with education. Specifically, for lower levels of cognitive reserve ( $-1$  *SD* of education), the longitudinal association between relational reserve in the first wave and subsequent changes in executive functioning was not significant. In contrast, for higher levels of cognitive reserve ( $+1$  *SD* of education), a higher relational reserve in the first wave significantly predicted a smaller subsequent increase in TMT completion time from the first to the second wave (i.e., a smaller decline in executive functioning).

*Discussion:* The present longitudinal study provides evidence for the interaction between cognitive and relational reserves. This confirms the hypothesis that reserves from different domains are intertwined and their combined effects contribute to less cognitive decline in old age.

*Keywords:* family; life course; longitudinal study

## Introduction

Cognitive functioning is a key determinant of quality of life and the ability to maintain independence in old age (Fratiglioni, Paillard-Borg, & Winblad, 2004; Stern, 2009; Valenzuela, 2008). Although older age is generally associated with an increased risk for declines in cognitive functioning, considerable inter-individual differences in the rate and timing exist (Albert et al., 1995). Efforts to identify the mechanisms that influence these inter-individual differences in cognitive decline have become increasingly important over the past years (Stern, 2013). Therefore, a major purpose in current gerontological neuropsychology is to better understand how inter-individual differences in cognitive health in old age emerge (Opdebeeck, Martyr, & Clare, 2016). In this context, the cognitive reserve concept postulates that lifelong experiences, including educational and occupational attainment, and leisure activities in later life, stimulate brain development. As a consequence, reserve capacity can be increased, which may compensate for brain damage, neurological loss, and pathological decline later on and therefore preserving cognitive functioning in older age. This was hypothesized to take place via a more effective recruitment of neural networks and cognitive processes (Stern, 2009, 2013).

The relevance of cognitive reserve enhancing factors as contributors to for instance decreased dementia risk has emerged from several longitudinal population-based studies (Fratiglioni et al., 2004; Valenzuela, 2008) and has been confirmed by pathological and clinical data (Bennett et al., 2003). Several studies have reported an increased risk of dementia in less educated individuals (Bennett et al., 2003; Meng & D'Arcy, 2012). Higher education may help to build cognitive reserve (De Ronchi et al., 1998; Dekhtyar et al., 2015). In addition to early life contributors, cognitive functioning in older age is promoted by adulthood factors, such as occupational status (Ihle, Oris, Fagot, Maggiori, & Kliegel, 2016), leisure activities (Ihle et al., 2019; Ihle et al., 2017; Sauter, Widmer, Ihle, & Kliegel, 2019), and relational reserve (Ihle, Oris, Sauter, Rimmele, & Kliegel, 2018; Sauter et al., 2019). With

regards to relational reserve, it has been shown that leading a socially active life and being socially engaged (as a result of greater embeddedness in personal networks) is beneficial to buffer cognitive decline and lower risks of dementia (Ellwardt, van Tilburg, Aartsen, Wittek, & Steverink, 2015). The explanation lies in the brain activity that results from the interaction with others, thereby enhancing cognitive functioning (Hultsch, Hertzog, Small, & Dixon, 1999).

In general, ‘reserves’ are defined as resources which are not needed for immediate use but which, when accumulated to a sufficient extent, are available to recover from life shocks and adversity, social or economic stressors, or non-normative transitory periods across the life course (Cullati, Kliegel, & Widmer, 2018). Literature stressed the critical processes of reserve constitution, activation and reconstitution for the understanding of individual resilience against cognitive decline (Ihle, Ghisletta, et al., 2018; Ihle, Oris, Sauter, et al., 2018). With respect to relational reserve, literature stresses that social support and social capital contribute to such resilience (Furstenberg & Kaplan, 2004). They may thus constitute a reserve of their own, relational in nature. Accordingly, we define relational reserve as constituted by pools of significant network members who, because of a history of supportive relationships with the individual, are able to be providers for that individual of e.g. emotional support in order to recover from life shocks and adversity or demanding life transitions (Sauter, Widmer, & Kliegel, under review).

However, few studies have been able to examine the effects of cumulative exposure to different reserve domains and enhancing factors for cognitive and relational reserve across different moments over the lifespan. Exposure to these factors may act alone or interact with other factors, affecting cognitive functioning in later life. Yet, a longitudinal investigation of these patterns with respect to cognitive decline is missing so far.

To address this gap in the literature, we investigated the longitudinal association of cognitive reserve (as indicated by education) and relational reserve (as indicated by the family

network size and indices of emotional support) to subsequent decline in executive functioning over six years as measured through performance changes in the Trail Making Test (TMT). In particular, we examined whether cognitive reserve and relational reserve interacted with respect to this longitudinal association, while taking into account conflict relationships and the age structure of the individuals' social network, as well as individuals' age and sex as covariates. We included the latter covariates as previous studies reported that men had a significantly steeper decline in cognitive functioning than women (Barrett-Connor & Kritz-Silverstein, 1999) and that generally older individuals have worse cognitive performances than their younger counterparts (Barnes et al., 2003; Barrett-Connor & Kritz-Silverstein, 1999; Perls, Morris, Ooi, & Lipsitz, 1993).

## Methods

### Participants

Data for the present study come from the Vivre-Leben-Vivere (VLV) survey which aims to investigate the health and living conditions of older adults (65 years and above) living in Switzerland. Respondents were first interviewed during 2011 (Wave 1; W1) and again in 2017 (Wave 2; W2) using face-to-face computer-assisted personal interviewing (CAPI) and paper-pencil questionnaires. In W1, the survey was carried out in five Swiss cantons (Basel, Bern, Geneva, Valais, and Ticino) representing the three linguistic regions of Switzerland (German-, French-, and Italian-speaking). The initial W1 sample ( $N = 3,080$ ) was randomly selected in the cantonal and national population records and stratified by age (65–69, 70–74, 75–79, 80–84, 85–89, 90 and older), sex, and canton. In W2, a subsample of 1,059 participants from four cantons (Basel, Bern, Geneva, and Valais) was interviewed again. Present analyses were based on 897 individuals who participated in the two waves of the survey and who had completed the Trail-Making-Test A and B, the outcome variables in the present study (Ihle et al., 2015; Ihle, Ghisletta, et al., 2018; Ihle, Oris, Fagot, Maggiori, et al.,

2016; Oris et al., 2016). Mean age of these respondents in W1 was 74.33 years ( $SD = 6.50$ , range 65-96).

Reflecting the longitudinal study design, our sample only contained survivors.<sup>1</sup> Compared to all 3,080 participants initially tested in W1, the 897 participants retained in the present study were younger ( $M = 74.33$  years in W1,  $SD = 6.50$ ) than the 2,183 individuals who were lost at follow-up in W2 ( $M = 80.00$  years in W1,  $SD = 8.60$ ;  $p < .001$ ). Importantly though, our sample still contained a considerable proportion of respondents aged 85 years and older in W2 (24.5% in W2 among the participants who were analyzed in the present study; in comparison, 25.7% in W1 among the participants initially tested in W1). The fraction of male vs. female participants did not differ significantly between our analytical sample and individuals who were lost at follow-up in W2 (51.4% vs 51.9% men,  $p = .811$ ). With respect to network size, the participants retained in the present study had slightly more significant family members in W1 ( $M = 3.75$ ,  $SD = 1.42$ ) than the individuals who were lost at follow-up in W2 ( $M = 3.21$  in W1,  $SD = 1.53$ ;  $p < .001$ ). Yet, our sample still contained a considerable proportion of respondents with relatively small networks of 3 or fewer persons in W2 (49.2% in W2 among the participants who were analyzed in the present study; in comparison, 41.6% in W1 among the participants initially tested in W1). Also, among the participants retained in the present study network size did not change from W1 ( $M = 3.75$ ,  $SD = 1.42$ ) to W2 ( $M = 3.74$ ,  $SD = 1.30$ ;  $p = .832$ ). Moreover, with respect to years of education the participants retained in the present study ( $M = 14.69$ ,  $SD = 5.35$ ) had higher levels of education than the individuals who were lost at follow-up in W2 ( $M = 13.63$ ,  $SD = 5.02$ ;  $p = .034$ ). However, our sample still contained a considerable proportion of respondents with lower educational levels (43.2% individuals with primary school level and lower levels of secondary school as well as vocational degrees among the participants who were analyzed in the present study; in comparison, 53.6% among the participants initially tested in W1). Thus, systematic attrition did not eliminate entire population groups of interest (see e.g. Aartsen, Smits, van Tilburg,

Knipscheer, & Deeg, 2002, for comparable retention patterns over six years in the Longitudinal Aging Study Amsterdam; see e.g. Hultsch, Hertzog, Small, & Dixon, 1999, for a similar follow-up of participants over six years in the Victoria Longitudinal Study; see e.g. Lifshitz-Vahav, Shrira, & Bodner, 2017, for a similar follow-up of participants over four years in the Survey of Health, Ageing and Retirement in Europe).

All participants gave their written informed consent for inclusion in the study before participating. The present study was conducted in accordance with the Declaration of Helsinki, and the study protocol had been approved by the ethics commission of the Faculty of Psychology and Social Sciences of the University of Geneva (project identification codes: CE\_FPSE\_14.10.2010 and CE\_FPSE\_05.04.2017).

## **Materials**

### *Trail Making Test Completion Time*

In both waves, we administered the Trail Making Test part A (TMT A) (Reitan, 1958). After one exercise trail (connecting the numbers from 1 to 8), participants had to connect the numbers from 1 to 25 as fast as possible and without error in ascending order. The TMT A completion time was the time in seconds needed to correctly connect the 25 numbers.<sup>2</sup>

In addition, we administered in both waves the Trail Making Test part B (TMT B). After one exercise trail (connecting 1-A-2-B-3-C-4-D), participants had to connect the numbers 1 to 13 in ascending order and the letters A to L in alphabetic order while alternating between numbers and letters (i.e., 1-A-2-B-3-C ... 12-L-13) as fast as possible and without error. The TMT B completion time was the time in seconds needed to correctly connect the 25 numbers / letters.

### *Relational Reserve*

Following standard measurement of relational reserves stemming from personal networks (Girardin & Widmer, 2015; Girardin et al., 2018), we measured relational reserve by family network size as well as indices regarding quality of relationships in the individual's

network. In accordance with our outlined definition, relational reserve is constituted of significant network members who, because of a history of supportive relationships with the individual, are able to be providers for that individual of e.g. emotional support in order to recover from life shocks and adversity or demanding life transitions (Sauter et al., under review). By applying standard procedures for collecting information on family networks (Widmer, Aeby, & Sapin, 2013), respondents were asked to name their most significant family members in W1. Due to questionnaire lengths, respondents' answers were limited to five family members. To keep responses as close as possible to the individual's understanding of 'family', participants were asked to use their own definition of who is a member of their 'family', which thus is not limited to blood ties or household limits only and could also include e.g. close friends, neighbors, colleagues, etc. (Girardin & Widmer, 2015). Thus, the term 'family' is used in the following with respect to this broader meaning. Participants were told that the term '*significant*' referred to people in their family who have played an either positive or negative role during the past year. This kind of open question allowed to capture supportive but also ambivalent relationships that occur within family networks.

To capture supportive relationships within their family network, participants were asked a set of questions about support among the family members they listed. Emotional support was defined as the ability to provide guidance and moral comfort. It was investigated with the following question: "Who would give emotional support to X [i.e., each individual included in the respondent's family configuration, considered one by one] during routine or minor troubles?". Based on the responses provided, we assessed a variety of network indices to measure relational reserve in egocentric networks. Network size was used as a general indicator of relational reserve, with the greater the number of family members, the higher the potential support providers. Network size measured the number (varying from 0-5) of family members included in the respondent's network. Density and reciprocity are classical indicators for the bonding dimension of relational reserve. Bonding relational reserve refers to

situations in which a majority of network members are interconnected. Such situation enhances expectations, claims, obligations, and trust for the focal individual because of the larger collective nature of normative control and support (Coleman, 1988; Putnam, 2000). Emotional support network density indicated the interconnectivity of all network members with regard to emotional support. This indicator, which varies from 0 to 1, was measured by dividing the number of existing ties providing emotional support by the number of potential ties. A density of 1 indicated that all family network members were interconnected.

Emotional support network reciprocity designated the extent to which emotional support was exchanged reciprocally among network members. Therefore, it referred to the ratio of reciprocal ties providing emotional support to all existing ties between family network members. Like density, this index varies from 0 to 1 with 1 meaning that all ties within the network are reciprocal. Three further indices (in-degree, out-degree, and betweenness centrality) were assessed to measure other dimensions of relational reserve, referring to its bridging potential (Cornwell, 2009, 2011). The emotional support network in-degree and out-degree of respondents were computed to measure the intensity of the emotional support exchanges with its network members. The emotional support network in-degree indicated the number of family members for whom respondents provided emotional support. This index varies from 0 to 5, with 5 indicating that all mentioned network members received emotional support from the respondent. The emotional support network out-degree reflected the number of family members providing the respondent with emotional support. This index captures the capacity of respondents to mobilize emotional support among their network members. Like the in-degree, the out-degree index varies from 0 to 5, with 5 indicating that the respondent received emotional support from all family network members. The emotional support network betweenness centrality indicated whether respondents were intermediaries between their significant family members. This index was computed as the ratio of all the shortest emotional support paths between any two family members that went through the focal

individual (Hanneman & Riddle, 2005). Focal individuals are considered central if they are lying between all, or almost all, of their family members' connections. Betweenness centrality varies from 0 to 1, with 1 indicating that all the family members went through the respondent to reach each other. In summary, these different network indices allowed a multidimensional assessment of relational reserve.

To take ambivalent relationships that may occur within family networks into account, we controlled for network conflict density. Based on lists of significant family members, we investigated density of family conflict with the following question: "Each family has its conflicts and tensions. In your opinion, who makes X (i.e., each individual included in the respondent's family configuration, considered one by one) angry?". Respondents had to evaluate not only their own family relationships but also those among all of their significant family members (Widmer et al., 2013). Network conflict density described the extent to which all family members included were interconnected through conflict. It was measured by the number of conflicting ties divided by the number of potential ties (Hanneman & Riddle, 2005).

In the present study, we also took the network mean age (i.e., the mean age of the individuals' network members) as an indicator of the age structure of the individuals' social network into account.

### *Cognitive Reserve*

Cognitive reserve was measured by using education as a proxy, following other studies on cognitive functioning (Opdebeeck et al., 2016; Stern, 2013). We asked participants to indicate the total time in years they had spent for formal education (comprising formal school education, further formal courses, extended vocational courses, and training courses in adulthood).

## Statistical Analyses

We conducted latent change score modeling (McArdle, 2009) using the R package lavaan (Rosseel, 2012). The specification of our latent change score model is illustrated in Figure 1. Specifically, we modeled latent executive functioning factors of TMT completion time in W1 (constructed from scores in TMT parts A and B in W1) and W2 (constructed from scores in TMT parts A and B in W2) as well as a latent change variable regarding change in TMT completion time from W1 to W2. We enforced strong factorial invariance on the factor loadings, with intercepts of all indicators being fixed to zero to assure that the same executive functioning factor was assessed at both waves (Meredith & Teresi, 2006). We included several covariates that predicted latent change and were correlated with the latent executive functioning factor in W1: network size in W1, emotional support network density in W1, emotional support network reciprocity in W1, emotional support network in-degree in W1, emotional support network out-degree in W1, emotional support network betweenness centrality in W1, network conflict density in W1, network mean age in W1, education, age in W1, sex, and the interaction of the network indices in W1 with education. We also included associations between all covariates to take the dependencies among them into account.

We evaluated model fit as follows: Given that with large study samples the  $\chi^2$  test often indicates a significant deviation of the model matrix from the covariance matrix despite good model fit (Hu & Bentler, 1999), we inspected several additional fit indices. Specifically, we used the following criteria: Comparative Fit Index (good models:  $CFI > .95$ ), Incremental Fit Index (good models:  $IFI > .95$ ), Root Mean Square Error of Approximation (good models:  $RMSEA < .06$ ), and Standardized Root Mean Square Residual (good models:  $SRMR < .08$ ) (Hu & Bentler, 1999).

## Results

### Descriptive Statistics

Table 1 shows descriptive statistics of analyzed measures in terms of means and standard deviations as well as sample proportions. Comparing both waves, there were no statistically significant differences in the average completion time in either TMT A or TMT B ( $ps > .145$ ). The sample included 6.7% of singles, 65.8% of married, 8.7% of divorced, and 18.8% of widowed individuals. 86.7% of participants had at least one child.

### Latent Change Score Modeling

The latent change score model provided a very good statistical account of the data ( $\chi^2 = 21.01, df = 27, p = .786, CFI > .99, IFI > .99, RMSEA < .01, SRMR = .01$ ).

#### *Longitudinal Predictions of Subsequent Change in TMT Completion Time*

Greater emotional support network betweenness centrality in W1 significantly predicted a smaller subsequent increase in TMT completion time from W1 to W2 (i.e., a smaller decline in executive functioning; see upper panel of Table 2). Older individuals' age in W1 significantly predicted a larger subsequent increase in TMT completion time from W1 to W2 (i.e., steeper decline in executive functioning). Network size in W1, emotional support network density in W1, emotional support network reciprocity in W1, emotional support network in-degree in W1, emotional support network out-degree in W1, network conflict density in W1, network mean age in W1, education, and sex did not predict changes in TMT completion time. However, there was a significant interaction of network size in W1 with education. To illustrate this interaction, we estimated in our latent change score model the longitudinal association between network size in W1 and changes in TMT completion time at different values of the continuous variable education. Specifically, for participants with less education ( $-1 SD$ ), the longitudinal association between network size in W1 and subsequent changes in executive functioning was not significant ( $\beta = .01, p = .935$ ). In contrast, for participants with higher education ( $+1 SD$ ), a larger network size in W1 significantly

predicted a smaller subsequent increase in TMT completion time from W1 to W2 (i.e., a smaller decline in executive functioning,  $\beta = -.19, p = .012$ ; cf. Figure 2). Besides that, no other interactions of the network indices in W1 with education on latent changes in TMT completion time were observed.

#### *Cross-Sectional Correlations with TMT Completion Time in W1*

Greater emotional support network in-degree in W1 and higher education significantly correlated with shorter TMT completion time in W1 (i.e., better performance status in executive functioning; see lower panel of Table 2). Older network mean age in W1 and older individuals' age in W1 significantly correlated with longer TMT completion time in W1 (i.e., lower performance status in executive functioning). Network size in W1, emotional support network density in W1, emotional support network reciprocity in W1, emotional support network out-degree in W1, emotional support network betweenness centrality in W1, network conflict density in W1, and sex was not associated with TMT completion time in W1.

#### **Additional Analysis**

In an additional analysis, we tested whether the pattern observed was moderated by network mean age. For this purpose, we additionally entered a two-way interaction between network size in W1 and network mean age in W1, a two-way interaction between emotional support network betweenness centrality in W1 and network mean age in W1, a two-way interaction between education and network mean age in W1, and a three-way interaction between network size in W1, education, and network mean age in W1 in the latent change score model. In this model, all these four interactions with network mean age on changes in TMT completion time were non-significant (all  $ps > .457$ ). Network mean age in W1 did not predict changes in TMT completion time ( $\beta = .01, p = .860$ ). Importantly, with respect to our main study goal, the pattern remained largely unchanged and the interaction of network size in W1 with education on subsequent changes in TMT completion time remained significant ( $\beta = -.10, p = .018$ ).

## Discussion

The purpose of the present study was to investigate the interaction of cognitive reserve and relational reserve in their longitudinal associations to subsequent decline in executive functioning over six years as measured through performance changes in the TMT.

Cross-sectional examinations showed that higher relational reserve (indicated by greater emotional support network in-degree) was positively associated with a higher level of executive functioning (i.e., indicated by shorter TMT completion time). This finding is in line with previous research on the beneficial role of social engagement and contact for cognitive functioning (Ellwardt et al., 2015; Ihle, Oris, Sauter, et al., 2018; Sauter et al., 2019). The most prominent explanation for those findings is that social interactions are stimulating for the brain and contribute to higher levels of cognition. Moreover, we also found a cross-sectional positive association between higher education and higher level of executive functioning, a result which confirms a large body of literature focusing on the positive effect of education on cognitive functioning in older age (Ihle, Oris, Fagot, et al., 2018; Ihle, Oris, Fagot, Maggiori, et al., 2016). It has been documented to a great extent that higher levels of education act as a build-up mechanism of cognitive reserve and is therefore beneficial for cognition in old age (Opdebeeck et al., 2016).

With respect to the longitudinal investigation, higher relational reserve (indicated by greater emotional support network betweenness centrality) in the first wave predicted a smaller subsequent decline in executive functioning (i.e., indicated by a smaller increase in TMT completion time). Besides that, neither of the other relational reserve indicators, nor cognitive reserve, tested individually, had a significant effect on cognitive decline. However, and most interestingly, a joint effect of cognitive and relational reserve (in terms of network size) on cognitive decline was found in the longitudinal analysis. With respect to this interaction, our results show that only those who were able to accumulate higher cognitive reserve via education earlier in the life course benefitted from their relational reserve (in terms

of network size) to buffer cognitive decline. This latter finding suggests that higher cognitive reserve may be a necessary preliminary condition to have a beneficial effect from one's relational reserve later in life. Such joint effect of two different reserve domains, namely cognitive and relational reserves, underlines the importance to go beyond the sole use of markers of cognitive reserve and to consider reserves stemming from other life domains when investigating the inter-individual differences in cognitive decline (Cullati et al., 2018).

From a relational standpoint, these results can be explained by referring to the homophily principle (Burgess & Wallin, 1943; McPherson, Smith-Lovin, & Cook, 2001; Suitor & Keeton, 1997), as it postulates that people's personal networks are homogenous with regard to many sociodemographic, behavioral, and intrapersonal characteristics (Burgess & Wallin, 1943). Homophily limits people's social worlds in a way that has powerful implications for the information they receive, the attitude they form, and the interactions they experience. Accordingly, the family members with whom individuals interact are not chosen randomly. In our case, there was a substantial, positive correlation between respondents' level of education and the average level of education of their family members.<sup>3</sup> As a consequence, the networks in the sample that are composed of highly educated individuals are more likely to share cognitively stimulating exchanges and activities, which then in return reinforces cognitive reserve through these activities. In other words, the relational reserve is likely to multiply, through the educational homogeneity of the network, the impact of the education level of the focal person.

The linked lives principle is another relational principle that is reflected in our results (Bengtson, Elder, & Putney, 2005; Elder, 1998). It emphasizes the interconnectedness of lives, particularly when they are linked across generations by bonds of kinship. This is of particular interest in our study as we investigate family networks and their relational reserve. Indeed, individuals' lives are embedded in relationships with family members and are influenced by them. Complementary to the homophily principle, the linked lives principle

explains how people with similar levels of cognitive reserve are linked to each other, through family ties. Thus, it is not surprising that the respondents with higher cognitive reserve were also able to mobilize in a more efficient manner their relational reserve.

Alternatively, in terms of interpretation of our results one could also argue that the level of education makes only a difference for those who have a large network size. Again, this would be in line with the rationale detailed above with respect to the homophily and linked lives principles. In other words, it seems likely that those individuals with higher relational reserve may be also more able to activate, more efficiently use, or further increase their cognitive reserve. One possible pathway in this explanation could be that in such networks individuals probably share cognitively stimulating exchanges or activities for which a good educational basis is helpful, such as learning a new language that further contributes to the accumulation of cognitive reserve during one's life (Ihle, Oris, Fagot, & Kliegel, 2016). Again, the relational reserve presumably amplifies the impact of the education level of the focal person through the educational homogeneity of the network. Clearly, future research is needed to pin down the underlying mechanisms of the present findings in detail. Besides that, future research might also further disentangle the role of relationship quality, such as emotional support network betweenness centrality in our study (that is indicating whether an individual serves as intermediary between that individual's significant family members), and pure quantitative indicators, such as network size. In this regard, a further avenue for future research will be to further explore the role of relational reserve in terms of received support out of the network versus given support to the network members versus an intermediary supportive role within the social network and its aftereffects on cognitive aging trajectories, depending on individuals' cognitive reserve.

One could argue that 'toxic' relationships in the individuals' network may have a negative influence. Alternatively, it could be possible that negative relationship quality or conflict can be stimulating. Importantly, in our latent change score model we controlled for

network conflict density and took all associations between all variables into account (thus, controlling also for the associations between network conflict density and the network indices). Therefore, we argue that our findings are robust against such potential confounding. Besides that, network conflict density in W1 did neither predict changes in TMT completion time nor was associated with TMT completion time in W1.

One could also argue that the age structure of the individuals' network may have an influence and that thereby it could make a difference if one has more contact with same-age family members or with younger or older ones. Importantly, in our latent change score model we controlled for network mean age (i.e., the mean age of the individuals' network members as an indicator of the age structure of the individuals' social network) and took all associations between all variables into account (thus, controlling also for the associations between network mean age and the network indices). Therefore, we argue that our findings are robust against such potential confounding. Moreover, in an additional analysis, we tested whether the main pattern observed was moderated by network mean age. With regard to our main study goal, this analysis revealed the same pattern of results, and, most importantly, that the observed two-way interaction of network size in W1 with education on latent change in TMT completion time did not vary by network mean age. Thus, it seems likely that present conclusions may hold irrespective of the individuals' network age structure. Yet, future research is needed to further elucidate this issue in more detail.

The present study has several limitations. The first relates to the fact that the name generator applied to gather information on family members was limited to five network members to keep interview times manageable. This limitation could have possibly hindered us from detecting additional effects on change. However, in very large surveys as the present one, it is a common approach to focus on the most significant family members (Marsden, 1987; Perry, 2018). Moreover, we acknowledge that our indices of emotional support are indicators of perceived support only, not actual support. Yet, importantly for our correlational

study that did not focus on the absolute amount of support of a certain individual, but, instead, investigated the role of inter-individual differences in the network indices, prior evidence showed that perceived and actual, received support when it was needed are considerably associated and therefore share a substantial amount of inter-individual differences (Melrose, Brown, & Wood, 2015). Nevertheless, future studies might consider further network indices including actual and perceived support. Second, we are conscious that the present correlational study does not allow drawing causal inferences. Moreover, we are aware that we can only draw conclusions regarding the time period and time scale captured in the present study since inter-individual differences in cognitive performance at any given point in time are the result of previous changes. Thus, we cannot make a deduction regarding a time period or time scale that was not captured in the present study. We acknowledge that therefore future longitudinal studies encompassing much broader phases of individuals' aging trajectories will have to investigate whether present observations hold over a broader time frame.

Furthermore, we recognize that due to the restrictive criteria for the TMT (see Footnote 2), there was a certain selection of the remaining sample. It may be possible that participants who properly did the test had better executive functioning than those who made an error. Thus, future research might investigate whether the present pattern of results holds also for tasks that allow error exclusion on a trial basis. In general, we acknowledge that the current study is limited by a relatively short assessment of cognitive performance. The battery of cognitive tests in the present study contained only a small number of cognitive tests, covering not all dimensions of cognitive functioning. Thus, future studies will have to examine whether the present pattern of results holds also for a larger set of cognitive abilities such as episodic memory, working memory, and a broader range of executive functions and thereby apply to the broader domain of cognitive functioning.

### Footnotes

<sup>1</sup> The major part of the selection occurred through the fact that over six years individuals had died between W1 and W2 ( $N = 501$ ), refused to continue ( $N = 463$ ), or moved away and thus could not be re-contacted ( $N = 451$ ). In addition, a subsample of participants in the canton Ticino that had participated in W1 could not be included in W2 due to funding restrictions ( $N = 606$ ).

<sup>2</sup> We terminated the TMT parts A / B (without any score) when the individual made any error in connecting the 25 numbers/letters in the respective test. We applied these restrictive criteria to be able to directly compare the completion times across individuals (i.e., completion times would be confounded when including participants who made errors and took additional time to correct them).

<sup>3</sup> There was a significant correlation between individuals' level of education and the average level of education of their family members (Spearman's  $\rho = .39$ ,  $p < .001$ ).

### Funding

This work was supported by the Swiss National Centre of Competence in Research LIVES – Overcoming vulnerability: Life course perspectives, which is financed by the Swiss National Science Foundation (grant number: 51NF40-160590).

### Acknowledgements

The authors are grateful to the Swiss National Science Foundation for its financial assistance. The authors also thank the participants of the Vivre-Leben-Vivere (VLV) study, as well as all members of the LIVES project IP213 and LINK institute who contributed to the realization of the VLV study. The data and materials for the current study are available from the corresponding author on request. This study was not preregistered.

### Conflict of interest

We declare that there is no conflict of interest.

## References

- Aartsen, M. J., Smits, C. H., Van Tilburg, T., Knipscheer, K. P., & Deeg, D. J. (2002). Activity in older adults: Cause or consequence of cognitive functioning? A longitudinal study on everyday activities and cognitive performance in older adults. *The Journals of Gerontology Series B: Psychological Sciences and Social Sciences*, *57*(2), P153–P162.
- Albert, M. S., Jones, K., Savage, C. R., Berkman, L., Seeman, T., Blazer, D., & Rowe, J. W. (1995). Predictors of cognitive change in older persons: MacArthur studies of successful aging. *Psychology and Aging*, *10*(4), 578–589.  
<https://doi.org/10.1037/0882-7974.10.4.578>
- Barnes, L. L., Wilson, R. S., Schneider, J. A., Bienias, J. L., Evans, D. A., & Bennett, D. A. (2003). Gender, cognitive decline, and risk of AD in older persons. *Neurology*, *60*(11), 1777. <https://doi.org/10.1212/01.WNL.0000065892.67099.2A>
- Barrett-Connor, E., & Kritz-Silverstein, D. (1999). Gender Differences in Cognitive Function with Age: The Rancho Bernardo Study. *Journal of the American Geriatrics Society*, *47*(2), 159–164. <https://doi.org/10.1111/j.1532-5415.1999.tb04573.x>
- Bengtson, V. L., Elder, G. H., & Putney, N. M. (2005). The life course perspective on ageing: Linked lives, timing, and history. In M. L. Johnson (Ed.), *The Cambridge Handbook of Age and Ageing* (Cambridge University Press, pp. 493–509). New York, NY.
- Bennett, D. A., Wilson, R. S., Schneider, J. A., Evans, D. A., Mendes de Leon, C. F., Arnold, S. E., ... Bienias, J. L. (2003). Education modifies the relation of AD pathology to level of cognitive function in older persons. *Neurology*, *60*(12), 1909.  
<https://doi.org/10.1212/01.WNL.0000069923.64550.9F>
- Burgess, E. W., & Wallin, P. (1943). Homogamy in Social Characteristics. *American Journal of Sociology*, *49*(2), 109–124. <https://doi.org/10.1086/219346>

- Coleman, J. S. (1988). Social Capital in the Creation of Human Capital. *American Journal of Sociology*, *94*, S95–S120. <https://doi.org/10.1086/228943>
- Cornwell, B. (2009). Network Bridging Potential in Later Life: Life-Course Experiences and Social Network Position. *Journal of Aging and Health*, *21*(1), 129–154. <https://doi.org/10.1177/0898264308328649>
- Cornwell, B. (2011). Independence Through Social Networks: Bridging Potential Among Older Women and Men. *The Journals of Gerontology: Series B*, *66B*(6), 782–794. <https://doi.org/10.1093/geronb/gbr111>
- Cullati, S., Kliegel, M., & Widmer, E. (2018). Development of reserves over the life course and onset of vulnerability in later life. *Nature Human Behaviour*, *2*(8), 551–558.
- De Ronchi, D., Fratiglioni, L., Rucci, P., Paternicò, A., Graziani, S., & Dalmonte, E. (1998). The effect of education on dementia occurrence in an Italian population with middle to high socioeconomic status. *Neurology*, *50*(5), 1231. <https://doi.org/10.1212/WNL.50.5.1231>
- Dekhtyar, S., Wang, H.-X., Scott, K., Goodman, A., Koupil, I., & Herlitz, A. (2015). A Life-Course Study of Cognitive Reserve in Dementia—From Childhood to Old Age. *The American Journal of Geriatric Psychiatry*, *23*(9), 885–896. <https://doi.org/10.1016/j.jagp.2015.02.002>
- Elder, G. H. (1998). The Life Course as Developmental Theory. *Child Development*, *69*(1), 1–12. <https://doi.org/10.1111/j.1467-8624.1998.tb06128.x>
- Ellwardt, L., van Tilburg, T., Aartsen, M., Wittek, R., & Steverink, N. (2015). Personal networks and mortality risk in older adults: A twenty-year longitudinal study. *PloS One*, *10*(3), e0116731.
- Fratiglioni, L., Paillard-Borg, S., & Winblad, B. (2004). An active and socially integrated lifestyle in late life might protect against dementia. *The Lancet Neurology*, *3*(6), 343–353. [https://doi.org/10.1016/S1474-4422\(04\)00767-7](https://doi.org/10.1016/S1474-4422(04)00767-7)

- Furstenberg, F. F., & Kaplan, S. B. (2004). Social Capital and the Family. In *The Blackwell Companion to the Sociology of Families* (Jacqueline Scott, Judith Treas, Martin Richards, pp. 218–232). Hoboken, NJ: John Wiley & Sons, Ltd.
- Girardin, M., & Widmer, E. D. (2015). Lay definitions of family and social capital in later life. *Personal Relationships*, 22(4), 712–737. <https://doi.org/10.1111/pere.12107>
- Girardin, M., Widmer, E. D., Connidis, I. A., Castrén, A.-M., Gouveia, R., & Masotti, B. (2018). Ambivalence in Later-Life Family Networks: Beyond Intergenerational Dyads. *Journal of Marriage and Family*, 80(3), 768–784. <https://doi.org/10.1111/jomf.12469>
- Hanneman, R. A., & Riddle, M. (2005). *Introduction to social network methods*. Retrieved from <http://faculty.ucr.edu/~hanneman/>
- Hu, L., & Bentler, P. M. (1999). Cutoff criteria for fit indexes in covariance structure analysis: Conventional criteria versus new alternatives. *Structural Equation Modeling: A Multidisciplinary Journal*, 6(1), 1–55. <https://doi.org/10.1080/10705519909540118>
- Hultsch, D. F., Hertzog, C., Small, B. J., & Dixon, R. A. (1999). Use it or lose it: Engaged lifestyle as a buffer of cognitive decline in aging? *Psychology and Aging*, 14(2), 245–263. <https://doi.org/10.1037/0882-7974.14.2.245>
- Ihle, A., Fagot, D., Vallet, F., Ballhausen, N., Mella, N., Baeriswyl, M., ... Kliegel, M. (2019). Cross-lagged relation of leisure activity participation to trail making test performance 6 years later: Differential patterns in old age and very old age. *Neuropsychology*, 33(2), 234–244. <https://doi.org/10.1037/neu0000497>
- Ihle, A., Gouveia, É. R., Gouveia, B. R., Linden, B. W. A. van der, Sauter, J., Gabriel, R., ... Kliegel, M. (2017). The Role of Leisure Activities in Mediating the Relationship between Physical Health and Well-Being: Differential Patterns in Old and Very Old Age. *Gerontology*, 63(6), 560–571. <https://doi.org/10.1159/000477628>

- Ihle, A., Oris, M., Fagot, D., Baeriswyl, M., Guichard, E., & Kliegel, M. (2015). The Association of Leisure Activities in Middle Adulthood with Cognitive Performance in Old Age: The Moderating Role of Educational Level. *Gerontology, 61*(6), 543–550. <https://doi.org/10.1159/000381311>
- Ihle, A., Ghisletta, P., Ballhausen, N., Fagot, D., Vallet, F., Baeriswyl, M., ... Kliegel, M. (2018). The role of cognitive reserve accumulated in midlife for the relation between chronic diseases and cognitive decline in old age: A longitudinal follow-up across six years. *Neuropsychologia, 121*, 37–46. <https://doi.org/10.1016/j.neuropsychologia.2018.10.013>
- Ihle, A., Oris, M., Fagot, D., Chicherio, C., Linden, B. W. A. van der, Sauter, J., & Kliegel, M. (2018). Associations of educational attainment and cognitive level of job with old age verbal ability and processing speed: The mediating role of chronic diseases. *Applied Neuropsychology: Adult, 25*(4), 356–362. <https://doi.org/10.1080/23279095.2017.1306525>
- Ihle, A., Oris, M., Fagot, D., & Kliegel, M. (2016). The relation of the number of languages spoken to performance in different cognitive abilities in old age. *Journal of Clinical and Experimental Neuropsychology, 38*(10), 1103–1114. <https://doi.org/10.1080/13803395.2016.1197184>
- Ihle, A., Oris, M., Fagot, D., Maggiori, C., & Kliegel, M. (2016). The association of educational attainment, cognitive level of job, and leisure activities during the course of adulthood with cognitive performance in old age: The role of openness to experience. *International Psychogeriatrics, 28*(05), 733–740. <https://doi.org/10.1017/S1041610215001933>
- Ihle, A., Oris, M., Sauter, J., Rimmele, U., & Kliegel, M. (2018). Cognitive Reserve and Social Capital Accrued in Early and Midlife Moderate the Relation of Psychological

- Stress to Cognitive Performance in Old Age. *Dementia and Geriatric Cognitive Disorders*, 45(3–4), 190–197. <https://doi.org/10.1159/000488052>
- Lifshitz-Vahav, H., Shrira, A., & Bodner, E. (2017). The reciprocal relationship between participation in leisure activities and cognitive functioning: The moderating effect of self-rated literacy level. *Aging & Mental Health*, 21(5), 524–531. <https://doi.org/10.1080/13607863.2015.1124838>
- Marsden, P. V. (1987). Core Discussion Networks of Americans. *American Sociological Review*, 52(1), 122–131. <https://doi.org/10.2307/2095397>
- McArdle, J. J. (2009). Latent Variable Modeling of Differences and Changes with Longitudinal Data. *Annual Review of Psychology*, 60(1), 577–605. <https://doi.org/10.1146/annurev.psych.60.110707.163612>
- McPherson, M., Smith-Lovin, L., & Cook, J. M. (2001). Birds of a Feather: Homophily in Social Networks. *Annual Review of Sociology*, 27(1), 415–444. <https://doi.org/10.1146/annurev.soc.27.1.415>
- Melrose, K. L., Brown, G. D. A., & Wood, A. M. (2015). When is received social support related to perceived support and well-being? When it is needed. *Personality and Individual Differences*, 77, 97–105. <https://doi.org/10.1016/j.paid.2014.12.047>
- Meng, X., & D'Arcy, C. (2012). Education and Dementia in the Context of the Cognitive Reserve Hypothesis: A Systematic Review with Meta-Analyses and Qualitative Analyses. *PLOS ONE*, 7(6), e38268. <https://doi.org/10.1371/journal.pone.0038268>
- Meredith, W., & Teresi, J. A. (2006). An Essay on Measurement and Factorial Invariance. *Medical Care*, 44(11), S69–S77. Retrieved from JSTOR.
- Opdebeeck, C., Martyr, A., & Clare, L. (2016). Cognitive reserve and cognitive function in healthy older people: A meta-analysis. *Aging, Neuropsychology, and Cognition*, 23(1), 40–60. <https://doi.org/10.1080/13825585.2015.1041450>

- Oris, M., Guichard, E., Nicolet, M., Gabriel, R., Tholomier, A., Monnot, C., ... Joye, D. (2016). Representation of Vulnerability and the Elderly. A Total Survey Error Perspective on the VLV Survey. In M. Oris, C. Roberts, D. Joye, & M. Ernst Stähli (Eds.), *Surveying Human Vulnerabilities across the Life Course* (pp. 27–64).  
[https://doi.org/10.1007/978-3-319-24157-9\\_2](https://doi.org/10.1007/978-3-319-24157-9_2)
- Perls, T. T., Morris, J. N., Ooi, W. L., & Lipsitz, L. A. (1993). The Relationship between Age, Gender and Cognitive Performance in the Very Old: The Effect of Selective Survival. *Journal of the American Geriatrics Society, 41*(11), 1193–1201.  
<https://doi.org/10.1111/j.1532-5415.1993.tb07302.x>
- Perry, B. L. (2018). *Egocentric network analysis: Foundations, methods, and models*. Retrieved from <http://data.rero.ch/01-R008774168/html>
- Putnam, R. D. (2000). Bowling Alone: America's Declining Social Capital. In *Culture and Politics* (pp. 223–234). [https://doi.org/10.1007/978-1-349-62397-6\\_12](https://doi.org/10.1007/978-1-349-62397-6_12)
- Reitan, R.M. (1958). Validity of the trail making test as an indicator of organic brain damage. *Perceptual and Motor Skills, 8*, 271–276.
- Rosseel, Y. (2012). lavaan: An R Package for Structural Equation Modeling. *Journal of Statistical Software, 48*, 1–36.
- Sauter, J., Widmer, E., Ihle, A., & Kliegel, M. (2019). The association of leisure activities in middle adulthood with cognitive performance in old age: Social capital mediates cognitive reserve effects. *Psychology & Neuroscience, 12*(2), 236–246.  
<https://doi.org/10.1037/pne0000146>
- Sauter, J., Widmer, E., & Kliegel, M. (under review). Changes in family composition and their effects on social capital in old age: Evidence from a longitudinal study conducted in Switzerland. *Ageing & Society*.
- Stern, Y. (2009). Cognitive reserve. *Neuropsychologia, 47*(10), 2015–2028.  
<https://doi.org/10.1016/j.neuropsychologia.2009.03.004>

- Stern, Y. (2013). *Cognitive Reserve: Theory and Applications*. Psychology Press.
- Suitor, J., & Keeton, S. (1997). Once a friend, always a friend? Effects of homophily on women's support networks across a decade. *Social Networks, 19*(1), 51–62. [https://doi.org/10.1016/S0378-8733\(96\)00290-0](https://doi.org/10.1016/S0378-8733(96)00290-0)
- Valenzuela, MJ. (2008). Brain reserve and the prevention of dementia. *Current Opinion in Psychiatry, 21*(3), 296–302. <https://doi.org/10.1097/YCO.0b013e3282f97b1f>
- Widmer, E. D., Aeby, G., & Sapin, M. (2013). Collecting family network data. *International Review of Sociology, 23*(1), 27–46. <https://doi.org/10.1080/03906701.2013.771049>

Table 1

*Descriptive statistics of analyzed measures*

Variable	<i>M (SD) /</i> sample proportions
TMT A completion time (W1) [seconds]	55.23 (24.40)
TMT A completion time (W2) [seconds]	56.03 (24.37)
TMT B completion time (W1) [seconds]	115.13 (44.80)
TMT B completion time (W2) [seconds]	108.90 (45.40)
Network size (W1) [number]	3.75 (1.42)
Network density (W1) [proportion]	0.39 (0.26)
Network reciprocity (W1) [proportion]	0.46 (0.32)
Network in-degree (W1) [number]	2.40 (1.52)
Network out-degree (W1) [number]	1.58 (1.29)
Network centrality (W1) [proportion]	0.15 (0.23)
Network conflict (W1) [proportion]	0.11 (0.18)
Network mean age (W1) [years]	53.16 (12.74)
Education [years]	14.69 (5.35)
Age (W1) [years]	74.33 (6.50)
Sex	men: 51.4% women: 48.6%

*Note:* Descriptive statistics for completion time in Trail Making Test (TMT) parts A and B in Wave 1 (W1) and Wave 2 (W2), network size in W1, emotional support network density in W1, emotional support network reciprocity in W1, emotional support network in-degree in W1, emotional support network out-degree in W1, emotional support network betweenness centrality in W1, network conflict density in W1, network mean age in W1, education, age in W1, and sex in terms of means (standard deviations are given in parentheses) as well as sample proportions.

Table 2

*Latent change score modeling results*

	<i>Estimate</i>
<b>Longitudinal predictions of subsequent change in TMT completion time</b>	
Network size (W1)	-.09 ns
Network density (W1)	.01 ns
Network reciprocity (W1)	-.07 ns
Network in-degree (W1)	.09 ns
Network out-degree (W1)	.08 ns
Network centrality (W1)	-.11*
Network conflict (W1)	-.01 ns
Network mean age (W1)	.01 ns
Education	.03 ns
Age (W1)	.34***
Sex (0 = men; 1 = women)	-.04 ns
Interaction of network size (W1) with education	-.10*
<b>Cross-sectional correlations with TMT completion time in W1</b>	
Network size (W1)	-.08 ns
Network density (W1)	-.05 ns
Network reciprocity (W1)	-.03 ns
Network in-degree (W1)	-.12**
Network out-degree (W1)	-.02 ns
Network centrality (W1)	.04 ns
Network conflict (W1)	-.06 ns
Network mean age (W1)	.11*
Education	-.22***
Age (W1)	.32***
Sex (0 = men; 1 = women)	.00 ns

*Note:* Parameter estimates of latent change score modeling. Upper panel: Longitudinal predictions of subsequent change in Trail Making Test (TMT) completion time from Wave 1 (W1) to Wave 2 (W2). Standardized

estimates  $\beta$  are given. Lower panel: Cross-sectional correlations with TMT completion time in W1. Standardized estimates  $r$  are given.

\*\*\*  $p < .001$ ; \*  $p < .05$ ; ns = non-significant,  $p > .05$ .

*Figure 1.* Specification of the tested latent change score model.  $E_1$  and  $E_2$  represent the latent executive functioning factors of Trail Making Test (TMT) completion time in Wave 1 (W1; constructed from scores in TMT parts A and B in W1) and Wave 2 (W2; constructed from scores in TMT parts A and B in W2), respectively.  $\Delta E$  represents the latent change in executive functioning variable regarding change in TMT completion time from W1 to W2. Note that for clarity purposes the illustration is simplified. We enforced strong factorial invariance on the factor loadings, with intercepts of all indicators being fixed to zero to assure that the same executive functioning factor was assessed at both waves. For simplification purposes, arrows from the triangle to the observed indicator variables (TMT A and B) that would indicate that intercepts of all indicators being fixed to zero are not displayed. cov represents all covariates that predicted latent change and were correlated with the latent executive functioning factor in W1: network size in W1, emotional support network density in W1, emotional support network reciprocity in W1, emotional support network in-degree in W1, emotional support network out-degree in W1, emotional support network betweenness centrality in W1, network conflict density in W1, network mean age in W1, education, age in W1, sex, and the interaction of the network indices in W1 with education (including associations between all covariates, which are not displayed here for a better overview).

*Figure 2.* Illustration of the interaction of network size in Wave 1 (W1) with education on latent change. Estimated mean increase in Trail Making Test (TMT) completion time from W1 to Wave 2 (W2) in seconds (i.e., decline in executive functioning) for a smaller and a larger network size in W1 (i.e., -1 and +1 SD, respectively) as a function of less versus higher education (i.e., -1 and +1 SD, respectively). Bars represent standard errors.

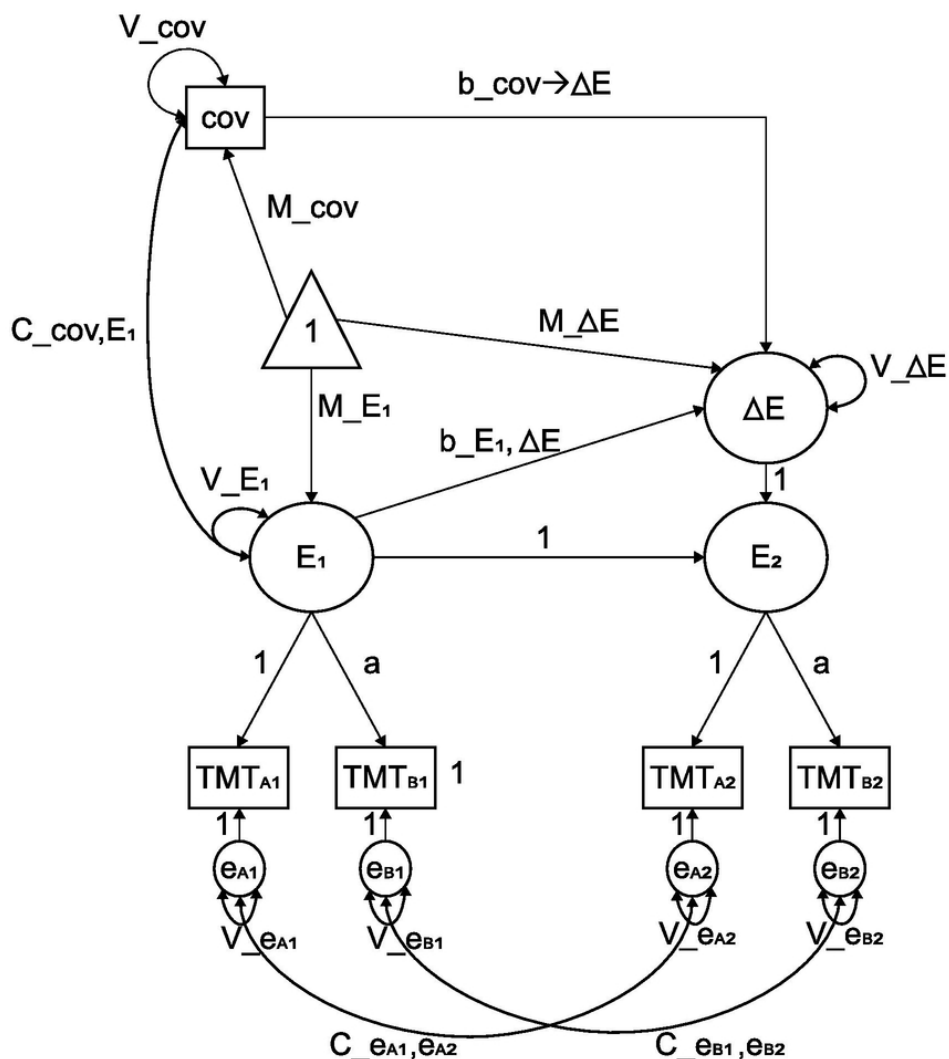

Figure 1. Specification of the tested latent change score model. E1 and E2 represent the latent executive functioning factors of Trail Making Test (TMT) completion time in Wave 1 (W1; constructed from scores in TMT parts A and B in W1) and Wave 2 (W2; constructed from scores in TMT parts A and B in W2), respectively.  $\Delta E$  represents the latent change in executive functioning variable regarding change in TMT completion time from W1 to W2. Note that for clarity purposes the illustration is simplified. We enforced strong factorial invariance on the factor loadings, with intercepts of all indicators being fixed to zero to assure that the same executive functioning factor was assessed at both waves. For simplification purposes, arrows from the triangle to the observed indicator variables (TMT A and B) that would indicate that intercepts of all indicators being fixed to zero are not displayed. cov represents all covariates that predicted latent change and were correlated with the latent executive functioning factor in W1: network size in W1, emotional support network density in W1, emotional support network reciprocity in W1, emotional support network in-degree in W1, emotional support network out-degree in W1, emotional support network betweenness centrality in W1, network conflict density in W1, network mean age in W1, education, age in W1, sex, and the interaction of the network indices in W1 with education (including associations between all covariates, which are not displayed here for a better overview).

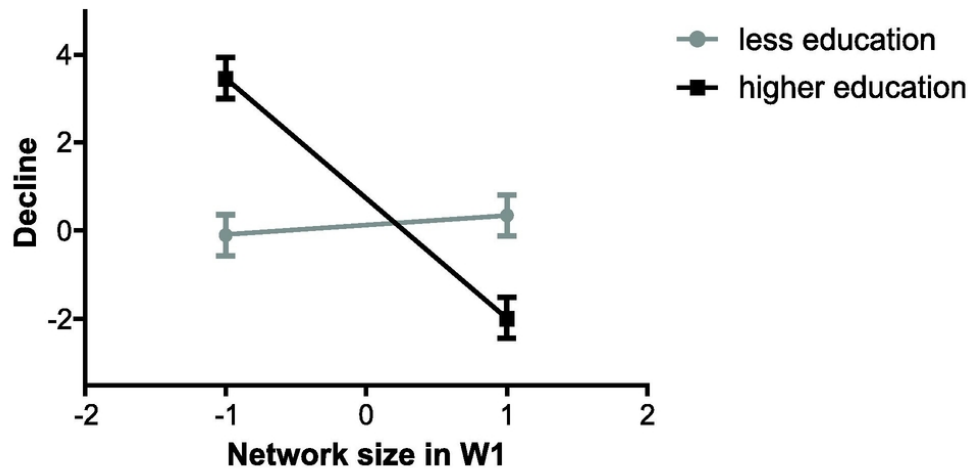

Figure 2. Illustration of the interaction of network size in Wave 1 (W1) with education on latent change. Estimated mean increase in Trail Making Test (TMT) completion time from W1 to Wave 2 (W2) in seconds (i.e., decline in executive functioning) for a smaller and a larger network size in W1 (i.e., -1 and +1 SD, respectively) as a function of less versus higher education (i.e., -1 and +1 SD, respectively). Bars represent standard errors.

82x44mm (300 x 300 DPI)