



Article scientifique

Article

2002

Published version

Public access

This is the published version of the publication, made available in accordance with the publisher's policy.

Stress distribution of inlay-anchored adhesive fixed partial dentures: a finite element analysis of the influence of restorative materials and abutment preparation design

Magne, Pascal; Perakis, Nikolaos; Belser, Urs Christophe; Krejci, Ivo

How to cite

MAGNE, Pascal et al. Stress distribution of inlay-anchored adhesive fixed partial dentures: a finite element analysis of the influence of restorative materials and abutment preparation design. In: The Journal of prosthetic dentistry, 2002, vol. 87, n° 5, p. 516–527. doi: 10.1067/mpr.2002.124367

This publication URL: <https://archive-ouverte.unige.ch/unige:84761>

Publication DOI: [10.1067/mpr.2002.124367](https://doi.org/10.1067/mpr.2002.124367)

© This document is protected by copyright. Please refer to copyright holder(s) for terms of use.

Last deposit update in Archive ouverte UNIGE on 15.03.2023 01:29

Stress distribution of inlay-anchored adhesive fixed partial dentures: A finite element analysis of the influence of restorative materials and abutment preparation design

Pascal Magne, PD, Dr Med Dent,^a Nikolaos Perakis, Dr Med Dent,^b Urs C. Belser, Prof Dr Med Dent,^c and Ivo Krejci, Prof Dr Med Dent^d

School of Dental Medicine, University of Geneva, Geneva, Switzerland

Statement of problem. Indirect composite or ceramic fixed partial dentures (FPDs) have become an alternative to conventional metal-ceramic adhesive fixed partial dentures (AFPDs). Little information about the adequate restorative material and tooth preparation design for inlay-anchored AFPDs is available to the clinician.

Purpose. The purposes of this simulation study were: (1) to use 2-dimensional finite element modeling to simulate stresses at the surface and interface of 3-unit posterior AFPDs made with 6 different restorative materials, and (2) to investigate the influence of 3 different abutment preparation configurations on the stress distribution within the tooth/restoration complex.

Material and methods. A mesio-distal cross-section of a 3-unit AFPD was digitized and used to create 2-dimensional models of the periodontal membrane, supporting bone, different restorative materials (gold, alumina, zirconia, glass-ceramic, composite, and fiber-reinforced composite), and different abutment preparation configurations (interproximal slots vs. 2-surface [MO, DO] vs. 3-surface [MOD]). A simulated 50-N vertical occlusal load was applied to the standardized pontic element. The principal stress within the restorative materials, stresses at the tooth/restoration interface, and surface tangential stresses at the level of the pontic were calculated in MPa from the postprocessing files and compared to each other.

Results. All materials and tooth preparation design exhibited a similar stress pattern, with a definite compressive area at the occlusal side of the pontic, a tensile zone at the gingival portion of the pontic, and tensile stress peaks in the abutment/pontic connection areas. Among isotropic materials, standard non-reinforced composites exhibited better stress transfer and reduced tensile stresses at the adhesive interface than ceramics and gold. Optimized placement of the glass fibers within the composite resulted in similar stress distribution when tested in 2-surface abutment preparation configuration. There was no detectable influence of preparation design on the behavior of the pontic area. Among all 3 preparation designs, only the DO design exhibited almost pure compression at the interface.

Conclusion. Within the limitations of this simulation experiment, the composite materials tested demonstrated a resilient component that favored stress transfer within the tooth/restoration complex. Their clinical use, however, may be contraindicated due to insufficient strength and fracture toughness. The addition of extremely tough fibers to composites represents the most promising combination. Clinical trials are required to ensure that veneering composite can survive under clinical conditions. (J Prosthet Dent 2002;87:516-27.)

CLINICAL IMPLICATIONS

In this finite element simulation study, the composite materials tested demonstrated a resilient component that favored stress transfer within the tooth/restoration complex. The addition of fibers to the composites represents a promising combination. Clinical trials are required to determine clinical outcomes.

Adhesive fixed partial dentures (AFPDs) are a useful conservative prosthodontic treatment option and

have proven their clinical reliability in combination with the metal-ceramic technique.^{1,2} The advent of metal-free restorative materials, however, has led to the use of indirect composite or ceramic fixed partial dentures (FPDs) as an alternative to conventional metal-ceramic AFPDs. Better bonding properties to composite cements, more appropriate biomechanical behavior, and enhanced esthetics are expected with the use of composite or ceramic compared to metal alloys.

^aSenior Lecturer, Department of Prosthodontics.

^bLecturer, Department of Prosthodontics and Department of Cariology, Endodontology, and Pediatric Dentistry.

^cProfessor and Chairman, Department of Prosthodontics.

^dProfessor and Chairman, Department of Cariology, Endodontology, and Pediatric Dentistry.

When an esthetic single-tooth replacement with a minimally invasive tooth reduction is desired and an implant is either contraindicated or refused by the patient, metal-free restorative options may be attractive. Since the bonding procedures strengthen the cusps and provide additional support for the dentition, minimally invasive preparation is feasible.³⁻⁵ Recent developments in the application mode of dentin adhesives⁶⁻⁸ have enabled the use of indirect (lab-made) bonded restorations.

Reinforced ceramics such as InCeram (Vita, Bad Säckingen, Germany) and Empress 2 (Ivoclar, Schaan, Liechtenstein)^{9,10} and composites^{11,12} such as Targis/Vectris (Ivoclar), Sculpture/Fibrekor (Jeneric/Pentron, Wallingford, Conn.), and Belleglass/Connect (Kerr, Orange, Calif.) have been proposed for the fabrication of metal-free AFPDs. The brittleness of ceramics makes this project difficult.¹³ In addition, high-elastic-modulus frameworks are expected to increase stress concentration at the adhesive interface, especially in the presence of long-span AFPDs.¹⁴ One theoretical claim is that lower-elastic-modulus frameworks would ensure a better stress transfer to the tooth and reduce tensile stresses at the adhesive interface,¹⁵ even though no scientific evidence has shown this to be true. Composites intrinsically feature this elastic behavior but seem to be limited by their low fracture toughness compared to other materials.¹⁶⁻¹⁸

Composites combined with fiber-reinforced materials seem to better comply with stress principles and provide a straightforward approach in the fabrication process. The performance of fiber-reinforced composites (FRCs) relies on adequate impregnation of the fibers by the resin monomer.¹⁹⁻²¹ The flexural properties and ultimate strength of FRCs have been explored in various load-to-failure experiments by Behr et al,²²⁻²⁴ who reported the ability of FRCs to withstand established chewing forces.²⁵ An alternative restorative approach was proposed that combined the flexural properties of FRCs and esthetic values of ceramics.²⁶ These studies provided insight into a number of biomechanical issues, yet they did not reveal the stress distribution within the tooth/restoration complex during occlusion and clenching.

Knowledge of stress distribution is important to the understanding of fatigue yielding, which generally occurs under subclinical micro-deformation (below the threshold of clinical observation). Overall stress distribution within the tooth/restoration complex is determined by geometry and hard tissue/restorative material arrangement.²⁷ As demonstrated by Reeh et al,²⁸ non-destructive approaches, rather than experimental load-to-failure, may be the best approach to determining significant differences in stress distribution. Non-destructive approaches can provide greater

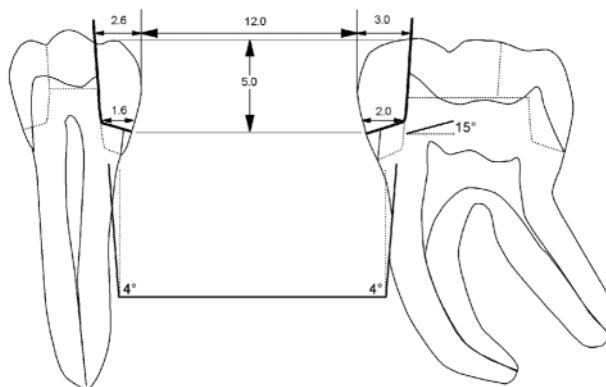

Fig. 1. Original contours developed from radiographic image of cemented 3-unit AFPDs. Dimensions are indicated in mm. Four-degree taper was maintained at level of pulpal walls and 15 degrees at gingival floor.

insight into the performance of both tooth and restorative materials but may require complex modeling tools such as the finite element (FE) method. Using the traditional biophysical knowledge database in a rational validation process, FE analysis has been significantly refined in recent years.²⁹ Experimental-numerical approaches now serve as comprehensive in vitro investigation methods for the examination of the complex mechanical behaviors of prostheses and surrounding structures.

The aim of this study was to evaluate the stress distribution at the surface and interface of 3-unit posterior AFPDs with the 2-dimensional FE method. Different restorative materials (gold, alumina, zirconia, glass-ceramic, composite, and fiber-reinforced composite) and abutment preparation configurations (interproximal slots; 2-surface distal-occlusal [DO] and mesial occlusal [MO]; and 3-surface mesial-occlusal-distal [MOD]) were compared.

MATERIAL AND METHODS

Two-dimensional finite element models derived from a mesio-distal cross-section of a 3-unit AFPD were subjected to a 50-N vertical occlusal load applied to the pontic element to evaluate 6 different restorative materials and 3 abutment preparation configurations. The postprocessing files allowed the calculation of the principal stress within the restorative materials, stresses at the tooth/restoration interface, and surface tangential stresses at the level of the pontic.

Definition of structures and geometric conditions

Two natural extracted teeth (a mandibular second premolar and second molar) were selected and mounted in epoxy resin (Epofix; Struers, Basel, Switzerland) to simulate a lateral dental segment with partial edentulism (missing first molar). A space of 12 mm was left

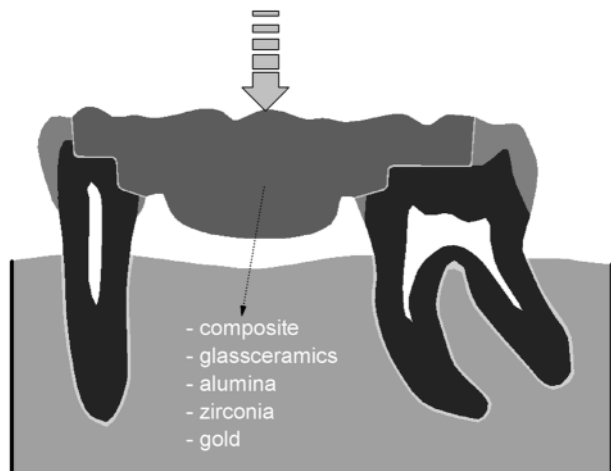

Fig. 2. Cross-sectional view of isotropic AFPD.

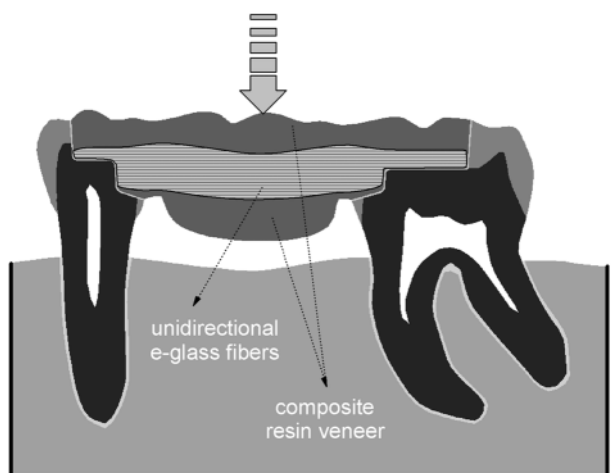

Fig. 3. Cross-sectional view of orthotropic AFPD. Luting composite thickness was 100 μ m (based on in vitro measurements²³).

between the 2 abutment teeth (an intact premolar and an intact second molar), which were prepared with only tapered interproximal slots of specific dimensions (Fig. 1). The corresponding FPD was fabricated with Targis/Vectris (Ivoclar) and adhesively luted with Variolink II (Vivadent, Schaan, Liechtenstein) according to guidelines described by Krejci et al¹² and Gohring et al.³⁰ A radiographic image of the 3-unit tooth/restoration complex was digitized with a scanning device (PhotoSmart S20; Hewlett-Packard, Palo Alto, Calif.) and used as a reference to trace the detailed contours of dental hard tissues and FPD components in a graphics software program (Freelance Graphics; Lotus, Cambridge, Mass.) (Fig. 1). Additional lines were drawn to simulate the periodontal ligament and portions of cortical and cancellous bone along with different tooth preparations and pontic infrastructure designs (Figs. 1 through 3). Luting

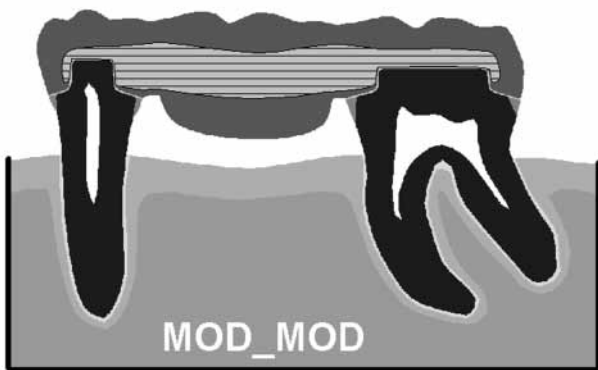
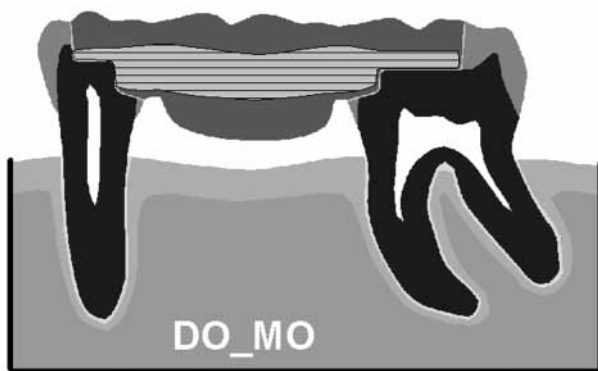
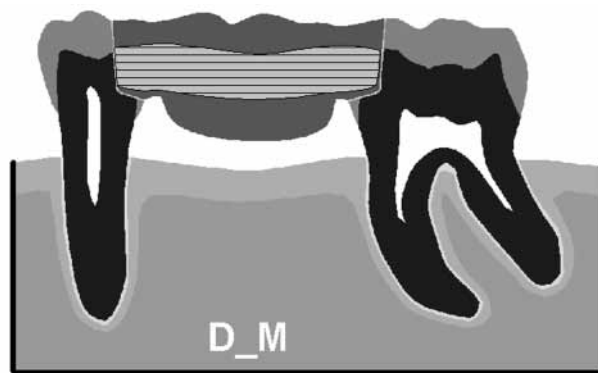

Fig. 4. Orthotropic FRC preparation configurations.

composite thickness was maintained at 100 μ m; this value was averaged on measurements made in an in vitro study.²³

To foster a systematic understanding of mechanical events, the simulation was performed in 2 steps. First, a general evaluation and characterization of stress distribution within the tooth/restoration complex was performed with various isotropic materials (composite, glass-ceramic, alumina, zirconia, gold) and 1 orthotropic product (unidirectional e-glass fiber reinforcement veneered with composite) in a 2-surface abutment preparation configuration (Figs. 2 and 3). This aim of this initial step was to identify the material that provided the most adequate stress transfer and

Table I. Isotropic material properties

| Material | Closest reference product | E modulus (GPa) | Ref no. | Poisson's ratio | Ref no. |
|---------------------------------------|------------------------------------------------|-----------------|---------|-----------------|---------|
| Enamel | — | 80.0 | 31 | 0.30 | 31 |
| Dentin | — | 17.6 | 32 | 0.25 | 32 |
| PDL | — | 0.027 | 33 | 0.45 | 33 |
| Cortical bone | — | 14.7 | 34 | 0.30 | 34 |
| Cancellous bone | — | 0.49 | 34 | 0.30 | 34 |
| Luting composite | Variolink II (Vivadent, Schaan, Liechtenstein) | 8.3 | * | 0.24 | 35 |
| Composite | Targis (Vivadent) | 12.3 | † | 0.24 | 35 |
| Feldspathic ceramic | Creation (Klema, Meiningen, Austria) | 70.0 | ‡ | 0.28 | 36 |
| Lithium disilicate glass-ceramic core | Empress II (Vivadent) | 96.0 | 37 | 0.25 | § |
| Alumina | InCeram Alumina (Vita, Bad Säckingen, Germany) | 418 | 38 | 0.22 | 39 |
| Zirconia | InCeram Zirconia (Vita) | 205 | 39 | 0.22 | 39 |
| Au-Pd alloy | Olympia (J.F. Jelenko, Armonk, N.Y.) | 103 | 40 | 0.33 | 41 |

*Data from Vivadent Variolink II technical data sheet (January 1997).

†Data from Vivadent Targis dentin technical data sheet (April 1997).

‡Data obtained from Klema (Meiningen, Austria).

§Data obtained from Ivoclar (Schaan, Liechtenstein).

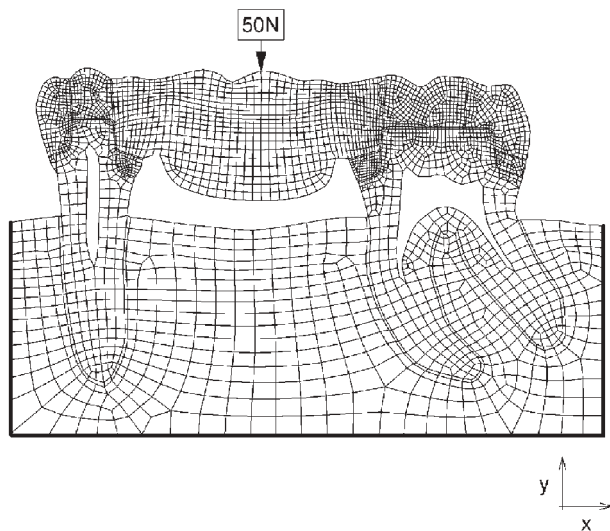

Fig. 5. Original 2-dimensional FE model (for isotropic testing) consisted of 3086 elements and 3259 nodes. Slight modifications were necessary to reproduce orthotropic model.

stress distribution. Second, an evaluation and characterization of stress distribution with different abutment preparation configurations was undertaken. To limit the amount of data obtained, this simulation was performed only for the best material identified in step 1. The following configurations were considered (Fig. 4): M_D (slot preparations on the surface adjacent to the pontic on each abutment), DO_MO (occluso-proximal preparation on the surface adjacent to the pontic on each abutment), and MOD_MOD.

Mesh generation and material properties (pre-processing)

All structures and defined contours were digitized

Table II. Orthotropic material properties (unidirectional continuous fiber composite)

| Vectris Pontic* | |
|------------------------------|----------|
| Longitudinal Young's modulus | 40.0 GPa |
| Transverse Young's modulus | 10.0 GPa |
| In-plane shear modulus | 3.1 GPa |
| Major Poisson's ratio | 0.25 |
| Transverse Poisson's ratio | 0.32 |

*Data generously provided by Dr Gianluca Zappini (Research and Development, Ivoclar, Schaan, Liechtenstein).

with the use of an image processing program (NIH Image; developed at the Research Services Branch of the National Institute of Mental Health, Bethesda, Md.). The computerized image was transferred to an interactive finite element program for mesh generation and pre-processing (Mentat 2000; MSC Software Co, Los Angeles, Calif.). A master mesh (plane strain elements, linear, 4-node, isoparametric, arbitrary quadrilateral) was developed for all restorative designs (Fig. 5). The original mesh was used for all isotropic models and had to be slightly modified (internal fiber reinforcement) to reproduce the orthotropic model.

Two mechanical material properties were required for each isotropic material: Poisson's ratio and elastic modulus. Most of these values, which are presented in Table I,³¹⁻⁴¹ were determined according to a literature survey. The situation was different for the orthotropic material. The engineering constants of a unidirectional continuous fiber composite can be predicted with various micro-mechanic models, starting from the properties of the matrix and fibers. A unidirectional continuous fiber composite like Vectris Pontic (Ivoclar) is a special composite with a grade of isotropy in the plane transverse to the fiber direction (these

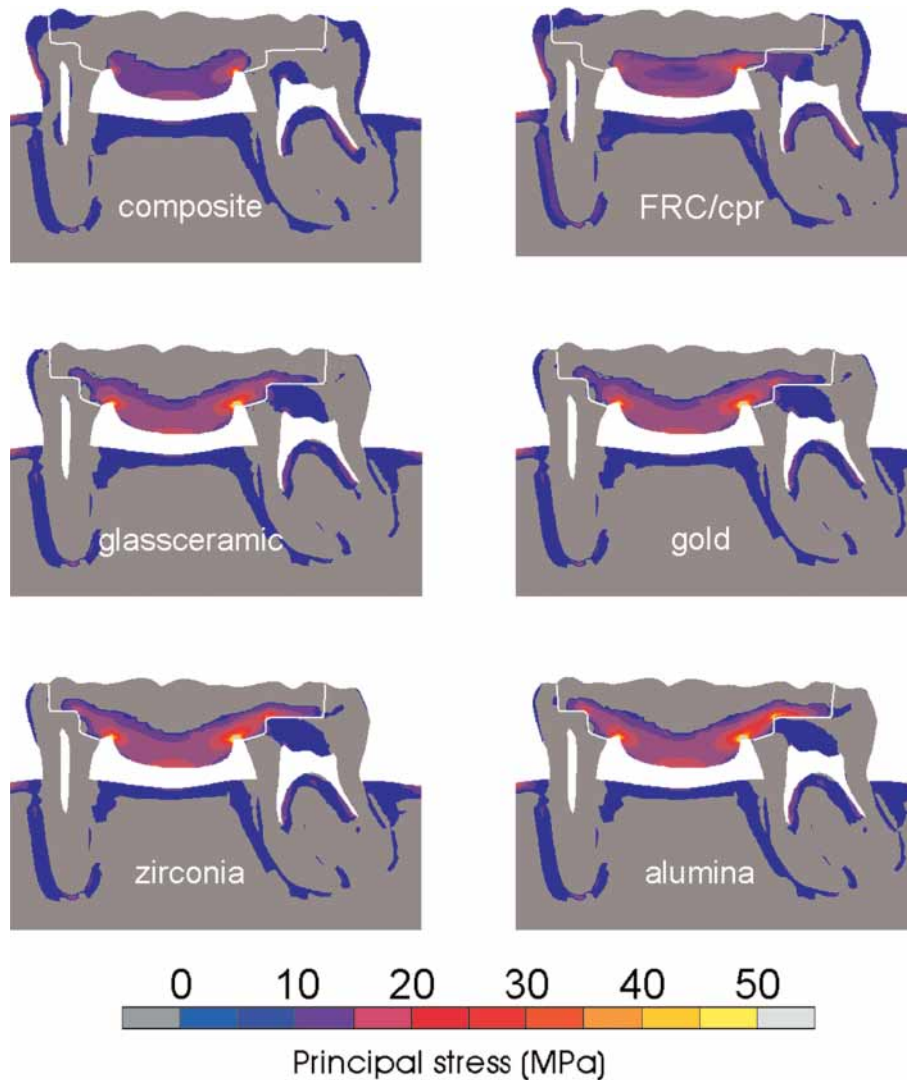

Fig. 6. Principal stress of various AFPDs in standard abutment configuration. Thin white line represents adhesive interface.

materials are also referred to as transversely isotropic). Only 5 elastic constants are therefore independent and sufficient to describe the composite's mechanical behavior (Table II).⁴²

Boundary conditions, loadcase, and data processing

Fixed zero-displacement in both the horizontal and vertical directions was defined at the horizontal and vertical cut-planes of the supporting bone, approximately 1.5 mm beyond the root structures. A static load was applied that corresponded to slow loading, assuming no vibrational or dynamic effects in the structure. To reflect the stress distribution at the moment of equilibrium, which also was recorded during reference fatigue studies that simulated adhesive FRC FPDs,^{22,23} a 50-N vertical occlusal load was applied to the pontic element as suggested by Krejci et

al.⁴³ The stress distribution within the 3-unit tooth/restoration cross-section was solved with the MARC 2000 Analysis solver (MSC Software Co). The post-processing file was accessed through the finite element program graphical interface (Mentat).

Stress distributions and special computations

Data were analyzed in 2 forms: (1) principal stress distribution (expressed in MPa by the software package) and (2) surface tangential stresses and interfacial stresses (MPa). Both dental hard tissues and non-metallic restoratives are brittle materials that exhibit higher strength in compression than in tension. The specific areas of compression and tension were evaluated in the form of principal stress maps. Principal stress can be defined as the stress in the direction for which the x and y components will display their maximum value. In view of the principal stress results, special

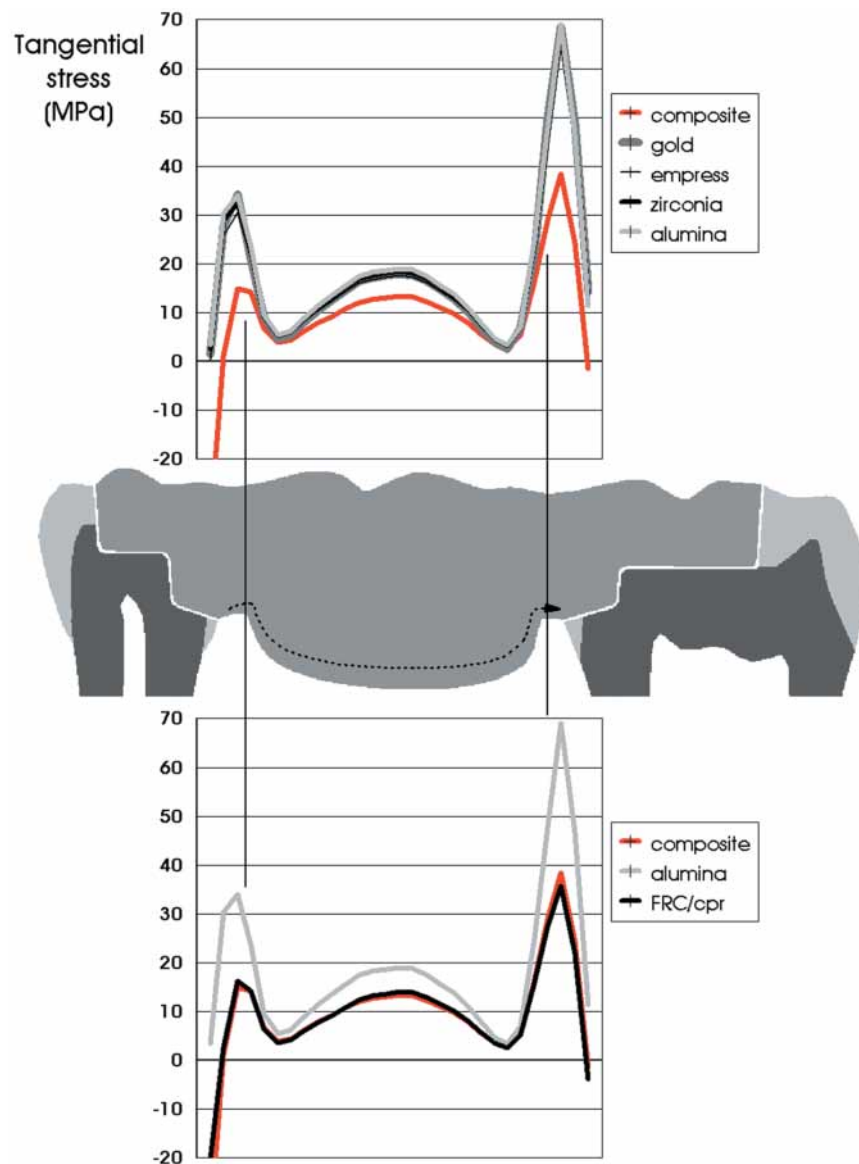

Fig. 7. Tangential stresses along gingival portion of pontic. Path plot proceeds from mesial to distal connection (*dotted arrow*). Upper plot features isotropic materials alone. *Black curve* in lower plot depicts orthotropic fiber-reinforced composite (isotropic composite and alumina plots added for comparison).

computations were performed to focus on relevant areas of the 3-unit tooth/restoration complex—namely, the tensile stress area of the pontic and the adhesive interface. Mentat software was used to select the node path along the pontic gingival surface (including connection areas) and to extract the values of stress in the x- and y-directions, the xy shear stress, and the node coordinates. After the transfer of these data to a spreadsheet, the surface tangential stress for each FE node located at the pontic gingival surface of the tooth was calculated with a specific transformation equation.⁴⁴ Similar data collection and transformation were used to calculate the interfacial stress (stress per-

pendicular to the tooth/luting composite interface) along the node path corresponding to the preparation outline (adhesive interface).

RESULTS

AFPDs in standard abutment preparation

The principal stress analysis for the 6 materials tested is presented in Figure 6. The stress pattern was similar for all materials and featured the typical stress distribution of a beam in a 3-point bending test: A definite compressive area extended between the neutral axis and the occlusal surface, and a tensile zone was

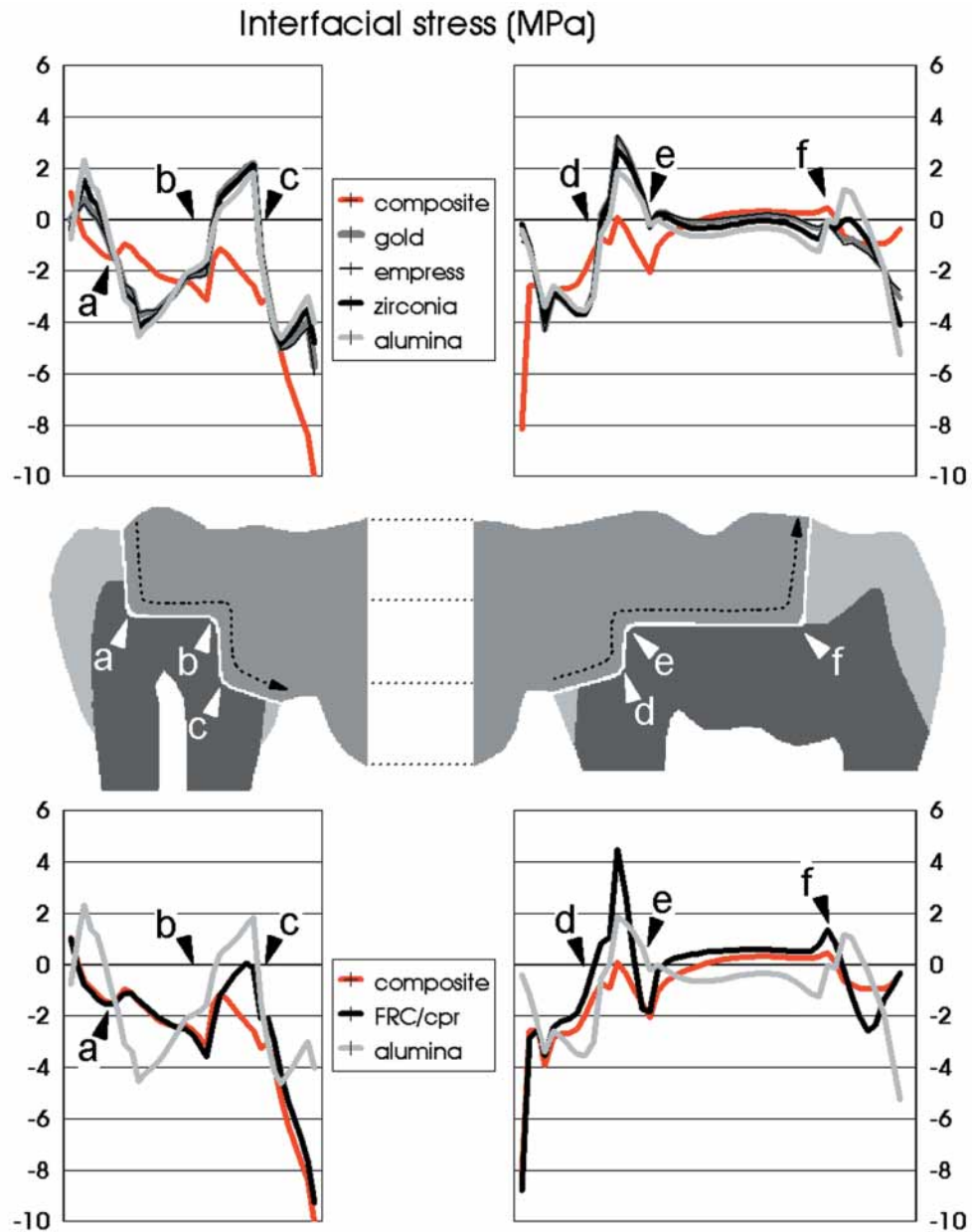

Fig. 8. Interfacial stresses along adhesive interface. Path plot proceeds from occlusal margin to proximal margin for premolar and from proximal margin to occlusal margin for molar. Upper plot features isotropic materials alone. *Black curve* in lower plot depicts orthotropic fiber-reinforced composite (isotropic composite and alumina plots added for comparison). Positive values represent tensile stresses. Some locations of adhesive interface (*arrowheads a to f*) are depicted on plots.

found at the gingival portion of the pontic. Tensile stresses were maximal at the gingival surface and concentrated in the connection areas. In all situations, the remaining tissues of the abutment teeth were subjected mainly to compressive or extremely low tensile forces.

Differences among materials were found in the way tensile stresses were distributed at the gingival portion of the pontic. The behavior of the composites (with or

without fiber reinforcement) clearly differed from that of the other materials. This observation was confirmed by an analysis of surface tangential stresses (Fig. 7), which showed the “low-stress” pattern of the composites peaking at 15 and 39 MPa at the mesial and distal connections, respectively, compared to 33 and 68 MPa for other materials. Stresses were always higher at the distal connection.

Differences also were found in the stresses at the

adhesive interface (Fig. 8). Isotropic composite AFPD exhibited a distinct behavior, with only compressive or very light tensile stresses. Tensile stress peaks were found with all other materials, including composite-reinforced orthotropic fibers. Tensile forces were high, especially at the level of the vertical walls for both abutment teeth (molar and premolar).

Orthotropic AFPDs (FRC) in various preparation configurations

Because of the favorable results described above, the FRC material was chosen for use in the second step of the experiment. This choice was empowered by the physico-chemical properties¹³ and clinical relevance of FRC materials.

The principal stress analysis for the 3 configurations tested is presented in Figure 9. The stress pattern was identical for all configurations and featured the typical stress distribution of the isotropic composite AFPD described in the previous section. There was no detectable influence of preparation design on the behavior of the pontic area. The intensity of the interfacial stresses (Fig. 10) appeared to be related to the location of the margin with regard to preexisting stresses within the abutment. Because tensile stresses are always present at the surface of a premolar abutment (except for the connection area), the margin of all 3 designs exhibited tensile interfacial stresses, especially at the mesial extension in the MOD design. This mesial cervical area consistently demonstrated a higher stress level. Among all 3 designs, only the DO exhibited almost pure compression at the interface. In the molar, a significant tensile peak was found at the base of the mesial axial wall. Except for this area, all interfaces exhibited compressive or low tensile stresses. Interestingly, the occlusal floor in the MO design was located exactly on the neutral axis that separated the compressive and tensile areas.

DISCUSSION

Although teeth are 3-dimensional structures, important mechanical events in 3-unit FPDs appear within the mesio-distal plane (general-beam model). These events support the use of the 2-dimensional plane-strain model for numerical analyses. The use of a 2-dimensional model is also valuable because of its improved performance in terms of element number and simulation quality. Although they are more realistic, 3-dimensional models provide a coarser mesh because of increased memory requirements that do not allow for the fine representation of tooth forms or thin layers (such as the luting composite, remaining enamel, or thin extensions of restorative material).

Overall stress distribution within the tooth/restoration complex is determined by geometry and hard tissue/restorative material arrangement,²⁷ which

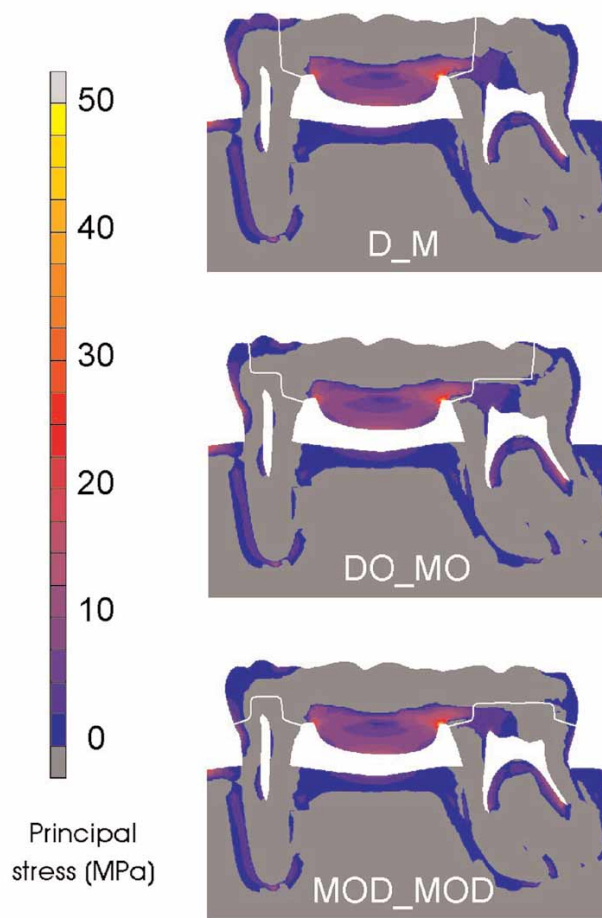

Fig. 9. Principal stress of orthotropic AFPDs in various abutment configurations. *Thin white line* represents adhesive interface.

explains the similar stress pattern observed for all materials, with the most critical areas represented by the connection areas (concavities) and the gingival portion of the pontic (tensile side of the “beam”).

Isotropic AFPDs in standard abutment preparation

The evaluation of stress distribution clearly favored composite AFPDs, which exhibited a low-stress pattern compared to stiffer materials, for which acute stresses were found, especially in critical structural areas (Fig. 6). One must keep in mind, however, that the effective damage generated by a given stress, especially tensile stress, is related to the ability of a given material to resist the propagation of cracks. This common property, called fracture toughness (critical value, tension mode, also K_{IC}), is listed in Figure 11 for various dental restoratives and biomaterials.¹⁶⁻¹⁸ Among brittle materials, composites exhibit the lowest values, which indicates that these materials alone cannot be considered for the clinical fabrication of AFPDs.

Improvements in toughness imply the association of

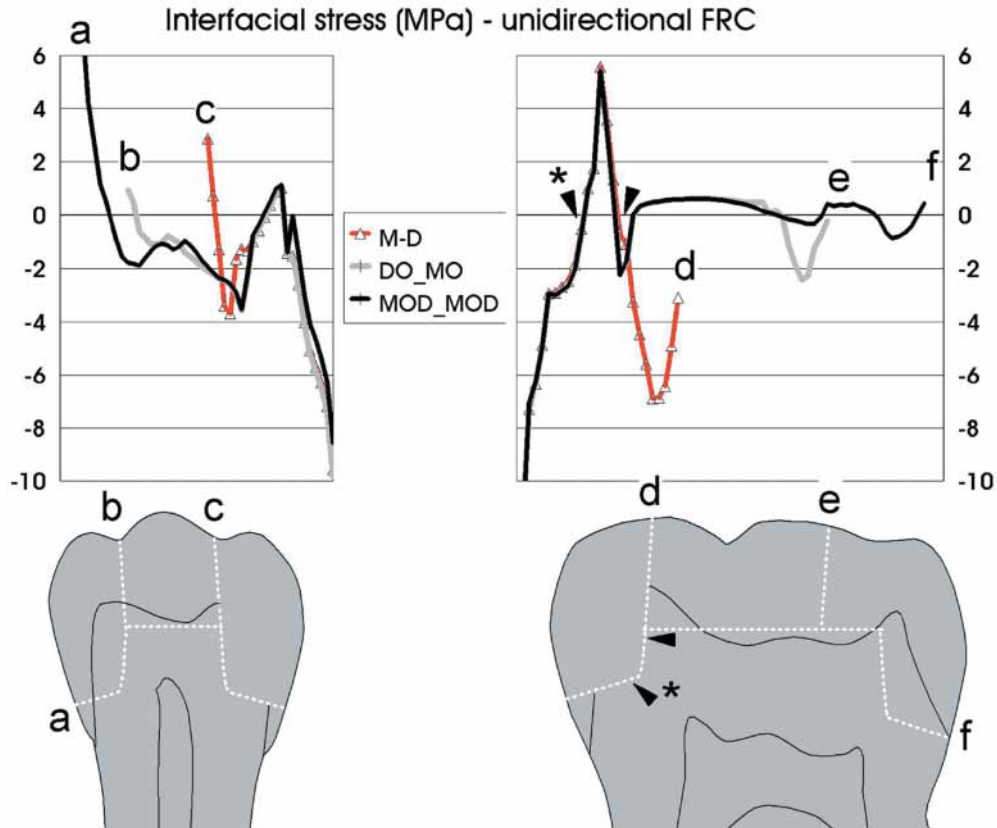

Fig. 10. Interfacial stresses along adhesive interface of orthotropic AFPDs in various abutment configurations. Path plot proceeds from occlusal margin (a, b, or c according to preparation type) to proximal margin for premolar and from proximal margin to occlusal margin for molar (d, e, or f according to preparation type). Significant tensile peak was found at base of axial pulpal wall of molar (arrowheads).

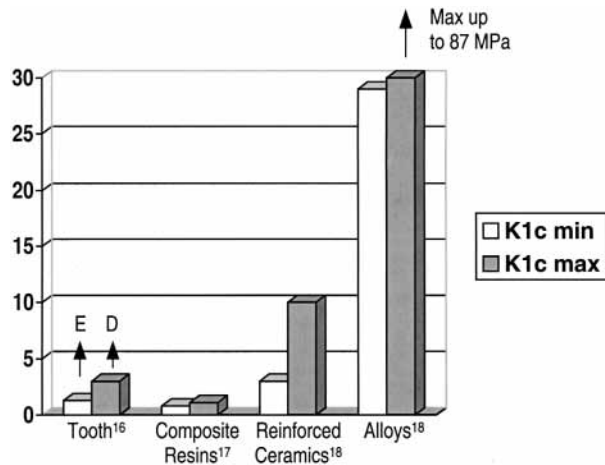

Fig. 11. Fracture toughness (MPa·m^{1/2}) of various biomaterials compared to enamel (E) and dentin (D).

fiber reinforcements in composites or the use of highly crystalline ceramics (alumina and zirconia). One major problem with ceramic materials is their brittleness and inherent lack of resilience. Given these

characteristics, the tooth position must allow a wide embrasure reduction since the weak point of the prosthesis will be at the interproximal contact points (Figs. 6 and 7). Another shortcoming of stiffer core materials relates to stress transfer to the adhesive interface: The toughest isotropic materials in this experiment (gold, alumina, zirconia) demonstrated significantly higher interfacial stresses (Fig. 8). These results confirm the assumptions of Vallittu et al,¹⁵ who favors more resilient materials. The only material able to produce a uniform compression of the adhesive interface under functional loading was the unreinforced composite. For all other materials, interfacial stresses exhibited a characteristic pattern that switched from compressive mode at the horizontal walls to tensile mode at the vertical walls (Fig. 8).

Orthotropic AFPDs

In dental reconstructions, uni-, bi-, or multi-directional fiber orientation can be used. Unidirectional fibers produce anisotropic (orthotropic) mechanical properties in the composite and are

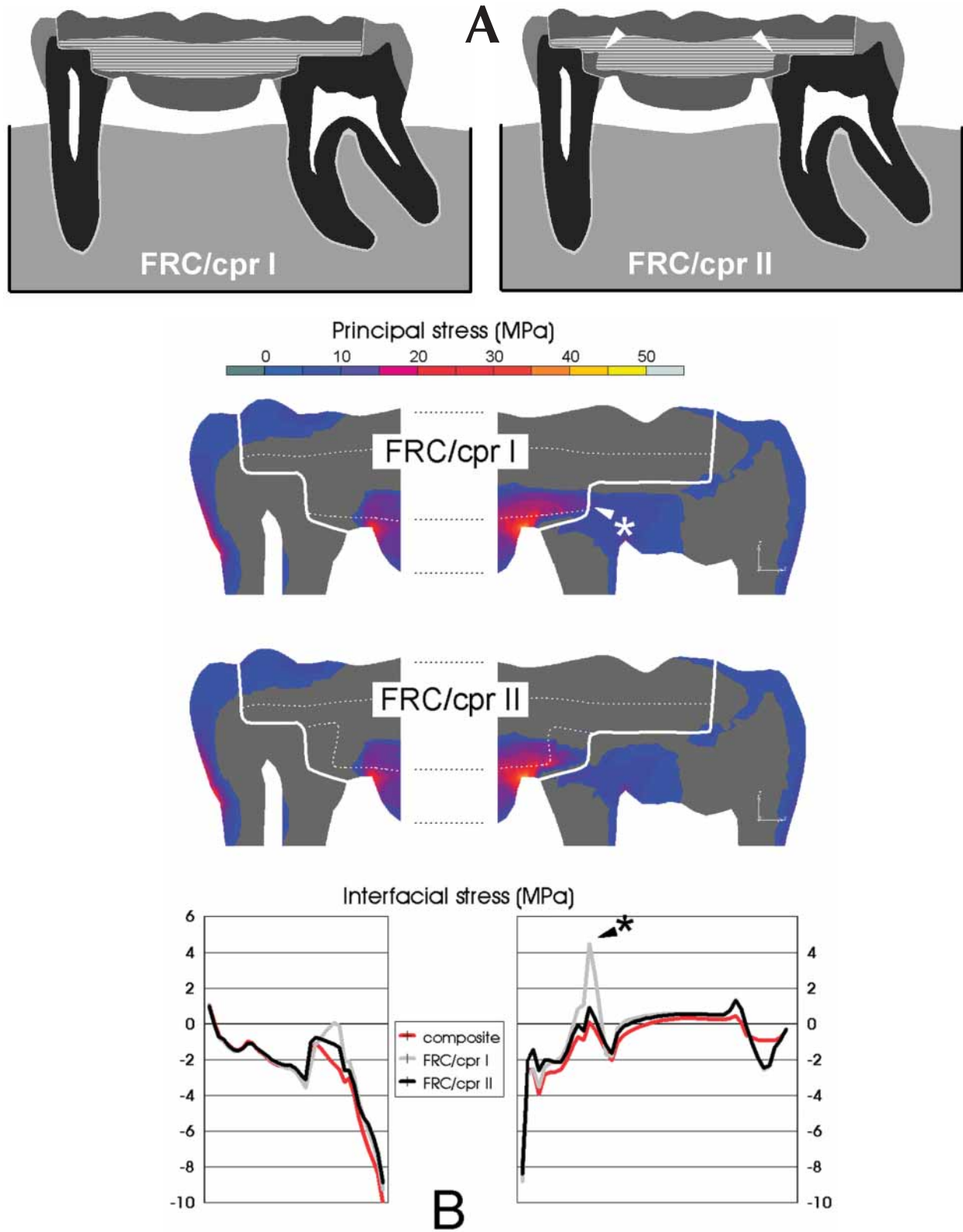

Fig. 12. A, Original (*left*) and optimized (*right*) fiber placement for fiber-reinforced composite AFPD. **B,** Principal stress of orthotropic AFPDs in standard abutment configuration. *Dotted white line* represents original and optimized fiber frame (*top*). Note interfacial stresses along adhesive interface (*bottom*; same path plot as in Fig. 10). Original tensile peak found at base of axial pulpal wall of molar (*asterisk*) could be reduced by optimized design of fiber-reinforced composite frame. Non-reinforced composite plot added for comparison.

preferred to multi-directional fibers when the direction of the highest stress is known.²³

Uni-directional fibers were used in the present analysis and corresponded to one possible application technique of the pontic element in the Targis-Vectris system. Load-to-failure experiments have demonstrated that artificially aged AFPDs made of Targis-Vectris can withstand loads of 600 to 700 N (applied to the pontic), which is well above the maximum chewing force measured in young patients with natural dentitions (~400 N).²⁵ The larger value also far exceeds the fracture strength of InCeram alumina.²² The main advantages of combining composites and fiber reinforcements are the resultant high strength values and simultaneous resilient component in the tooth/AFP complex. In the present study, resilience of the composite proved favorable in terms of stress transfer to the adhesive interface. It was also noted, however, that acute interfacial tensile stresses still occurred at the vertical preparation walls (pulpal wall), especially on the molar abutment (Fig. 8).

Using the same FE-mesh, the design of the pontic material was optimized to avoid contact with the pulpal wall (Fig 12, A). The resulting stress distribution was significantly improved through the reduction of tensile stress peaks at the interface (Fig 12, B). This optimized design did not raise the tensile stresses at the gingival level of the pontic. Perenniality of the adhesive interface, however, is also related to the dentin bonding agent. An ideal bond was simulated in this numeric analysis. In clinical reality, with the traditional application of a bonding agent, such a result might be difficult to achieve. Loose et al²² reported that the interface between the luting composite and tooth was the weakest point in the FPD joint. If a considerable area of dentin is exposed during tooth preparation, which is usually the case with AFPDs, it is suggested that a dentin adhesive be applied in a different mode.⁶⁻⁸

A significant problem is raised when exposed dentin is not protected between preparation procedures and insertion of the definitive prosthesis. Various extrinsic contaminants can alter further adhesion to dentin. This situation can be avoided through the immediate application of dentin adhesive at the time of tooth preparation, prior to the final impression.⁶⁻⁸ This precaution will not only result in an enhanced bond and protection of the pulp-dentin complex but also minimize tooth sensitivity during the provisional phase. When the restoration is bonded, the surface of the adhesive must be roughened with a bur or air-particle abrasion.⁸ The bonding procedure itself will, therefore, be limited to conditioning of the enamel involved (use of phosphoric acid etching followed by alcohol drying).

Preparation configuration

With regard to the ideal abutment configuration for

FRCs, extension of the preparation did not result in improved stress distribution. Interfacial stresses, as illustrated in Figure 9, indicated that preparation extension in the premolar abutment was not desirable and placed the mesial margin in tension mode. Whether the MOD configuration improved retention through increased primary stability and adhesion surface could be investigated further. In this study model, 2-surface abutments were the only configuration to exhibit almost pure compression at the interface. On the molar abutment, the preparation floor in the MO design was located exactly on the neutral axis (almost stress-free).

Limitations of FRCs

The weak point of fiber-reinforced composites is that they currently do not offer a durable esthetic result. Further research is required to demonstrate whether bulks of this material (such as large cusps on the pontic) can withstand long-term functional loading. An alternative approach would be to combine the flexural properties of FRCs and the esthetic values of ceramics.²⁶ Regarding the fiber reinforcement itself, the concentration of fibers (as obtained in vacuum-pressed Vectris) does not always lead to increased strength.²⁴ System success depends on the cohesiveness between the fibers and the surrounding resin matrix, which should ensure uniformity of stress transfer from the matrix to the fibers. For this reason, pre-impregnated FRCs are used: Glass fibers are covered with a silane coupling agent before they contact resin monomers.¹⁹ The presence of voids due to poorly impregnated fibers affects the loading-bearing capacity of the complex. As oxygen reservoirs, voids inhibit the polymerization of the acrylic resins inside the composite.²⁰ Furthermore, porosities can enhance the water sorption of FRCs with a detrimental effect on mechanical properties²¹ and discoloration due to the penetration of oral micro-organisms.

CONCLUSIONS

Within the limitations of this simulation experiment, the results suggest that AFPDs made of fiber-reinforced composite may be a viable alternative to traditional, more invasive FPDs. The potential of the system appears to lie in the combination of a resilient, flexible component (the composite) and strong reinforcement (glass fibers). Resiliency may prevent the development of harmful stresses at the adhesive interface, and reinforcement may protect the pontic from excessive strains, resulting in the restoration's ability to withstand high functional loads in vitro. In this study, 2-surface abutment preparations exhibited a substantial surface for adhesion and did not subject the interface to harmful stresses. A complementary analysis revealed that contact between the fiber frame and

the pulpal wall of the abutment preparation should be avoided. Clinical trials are required to ensure that veneering composite can survive under medium-to-long term clinical conditions, especially in its connection to the fiber frame at the critical level of the pontic.

We express our gratitude to Dr Antheunis Versluis (Associate Professor, Minnesota Dental Research Center for Biomaterials and Biomechanics) for his help in refining the finite element modeling and numerical output and to Dr Gianluca Zappini (Research and Development, Ivoclar) for computing the mechanical properties of Vectris Pontic.

REFERENCES

- Creugers NH. Resin bonded bridges. A status report for the American Journal of Dentistry. *Am J Dent* 1991;4:251-5.
- Kerschbaum T, Haastert B, Marinello CP. Risk of debonding in three-unit resin-bonded fixed partial dentures. *J Prosthet Dent* 1996;75:248-53.
- Wendt SL Jr. Microleakage and cusp fracture resistance of heat-treated composite resin inlays. *Am J Dent* 1991;4:10-4.
- Fissore B, Nicholls JI, Yuodelis RA. Load fatigue of teeth restored by a dentin bonding agent and a posterior composite resin. *J Prosthet Dent* 1991;65:80-5.
- Morin D, DeLong R, Douglas WH. Cusp reinforcement by the acid-etch technique. *J Dent Res* 1984;63:1075-8.
- Bertschinger C, Paul SJ, Luthy H, Scharer P. Dual application of dentin bonding agents: effect on bond strength. *Am J Dent* 1996;9:115-9.
- Paul SJ, Scharer P. The dual bonding technique: a modified method to improve adhesive luting procedures. *Int J Periodontics Restorative Dent* 1997;17:536-45.
- Magne P, Douglas WH. Porcelain veneers: dentin bonding optimization and biomimetic recovery of the crown. *Int J Prosthodont* 1999;12:111-21.
- Kern M, Knode H, Strubb JR. The all-porcelain, resin-bonded bridge. *Quintessence Int* 1991;22:257-62.
- Fradeani M, Barducci G. Lithium disilicate glass-ceramic restorations: indications and guidelines. *Quintessence Dent Technol* 2000;23:51-60.
- Altieri JV, Burstone CJ, Goldberg AJ, Patel AP. Longitudinal clinical evaluation of fiber-reinforced composite fixed partial dentures: a pilot study. *J Prosthet Dent* 1994;71:16-22.
- Krejci I, Boretti R, Giezendanner P, Lutz F. Adhesive crowns and fixed partial dentures fabricated of ceromer/FRC: clinical and laboratory procedures. *Pract Periodontics Aesthet Dent* 1998;10:487-98; quiz 500.
- Pospiech P, Rammelsberg P, Goldhofer G, Gernet W. All ceramic resin-bonded bridges. A 3-dimensional finite-element analysis study. *Eur J Oral Sci* 1996;104:390-5.
- Philips RW. Skinner's science of dental materials. 9th ed. Philadelphia: WB Saunders; 1991. p. 373-5.
- Vallittu PK, Sevelius C. Resin-bonded, glass fiber-reinforced composite fixed partial dentures: a clinical study. *J Prosthet Dent* 2000;84:413-8.
- El Mowafy OM, Watts DC. Fracture toughness of human dentin. *J Dent Res* 1986;65:677-81.
- Roberts JC, Powers JM, Craig RG. Fracture toughness of composite and unfilled restorative resins. *J Dent Res* 1977;56:748-53.
- Ashby MF, Jones DR. Engineering materials 2: an introduction to microstructures, processing and design. Oxford: Pergamon Press; 1986. p. 150-1.
- Goldberg AJ, Freilich MA. An innovative pre-impregnated glass fiber for reinforcing composites. *Dent Clin North Am* 1999;43:127-33, vi-vii.
- Vallittu PK, Ruyter IE, Ekstrand K. Effect of water storage on the flexural properties of E-glass and silica fiber acrylic resin composite. *Int J Prosthodont* 1998;11:340-50.
- Vallittu PK. Flexural properties of acrylic resin polymers reinforced with unidirectional and woven glass fibers. *J Prosthet Dent* 1999;81:318-26.
- Loose M, Rosentritt M, Leibrock A, Behr M, Handel G. In vitro study of fracture strength and marginal adaptation of fibre-reinforced-composite versus all ceramic fixed partial dentures. *Eur J Prosthodont Restor Dent* 1998;6:55-62.
- Behr M, Rosentritt M, Leibrock A, Schneider-Feyrer S, Handel G. In-vitro study of fracture strength and marginal adaptation of fibre-reinforced adhesive fixed partial inlay dentures. *J Dent* 1999;27:163-8.
- Behr M, Rosentritt M, Lang R, Handel G. Flexural properties of fiber reinforced composite using a vacuum/pressure or a manual adaptation manufacturing process. *J Dent* 2000;28:509-14.
- Fontijn-Tekamp FA, Slagter AP, Van Der Bilt A, Van 'T Hof MA, Witter DJ, Kalk W, Jansen JA. Biting and chewing in overdentures, full dentures, and natural dentitions. *J Dent Res* 2000;79:1519-24.
- Rosentritt M, Behr M, Lang R, Handel G. Experimental design of FPD made of all-ceramics and fiber-reinforced composite. *Dent Mater* 2000;16:159-65.
- Magne P, Versluis A, Douglas WH. Rationalization of incisor shape: experimental-numerical analysis. *J Prosthet Dent* 1999;81:345-55.
- Reeh ES, Douglas WH, Messer HH. Stiffness of endodontically-treated teeth related to restoration technique. *J Dent Res* 1989;68:1540-4.
- Koroth TW, Versluis A. Modeling the mechanical behavior of the jaws and their related structures by finite element (FE) analysis. *Crit Rev Oral Biol Med* 1997;8:90-104.
- Gohring TN, Mormann WH, Lutz F. Clinical and scanning electron microscopic evaluation of fiber-reinforced inlay fixed partial dentures: preliminary results after one year. *J Prosthet Dent* 1999;82:662-8.
- Craig RG, Peyton FA, Johnson, DW. Compressive properties of enamel, dental cements, and gold. *J Dent Res* 1961;40:936-45.
- Craig RG, Peyton FA. Elastic and mechanical properties of human dentin. *J Dent Res* 1958;37:710-8.
- Wider GE, Tesk JA, Privitzer E. Interaction effects among cortical bone, cancellous bone, and periodontal membrane of natural teeth and implants. *J Biomed Mater Res* 1976;10:613-23.
- Moroi HH, Okimoto K, Moroi R, Terada Y. Numeric approach to the bio-mechanical analysis of thermal effects in coated implants. *Int J Prosthodont* 1993;6:564-72.
- Craig RG, Powers JM. Restorative dental materials. 11th ed. St. Louis: CV Mosby; 2002. p. 79.
- Anusavice KJ, Hojjatie B. Influence of incisal length of ceramic and loading orientation on stress distribution in ceramic crowns. *J Dent Res* 1988;67:1371-5.
- Fischer H, Marx R. Mechanical properties of Empress 2 (in German). *Acta Med Dent Helv* 1999;4:141-5.
- Jones DW, Jones PA, Wilson HJ. The modulus of elasticity of dental ceramics. *Dent Pract Dent Rec* 1972;22:170-3.
- Callister WD. Properties of selected engineering materials. In: Callister WD, editor. Material science and engineering: an introduction. 4th ed. New York: John Wiley and Sons Inc; 1997. p. 778, 780.
- Morris HF. Veterans Administration Cooperative Studies Project No. 147/242. Part VII: The mechanical properties of metal ceramic alloys as cast and after simulated porcelain firing. *J Prosthet Dent* 1989;61:160-9.
- Anusavice KJ, Hojjatie B, Dehoff PH. Influence of metal thickness on stress distribution in metal-ceramic crowns. *J Dent Res* 1986;65:1173-8.
- Whitney JM, McCullough RL. Delaware composites design encyclopedia. Vol. 2: Micromechanical materials modeling. Lancaster (PA): Technomic Publishing Co Inc; 1990. Sections 2.1 and 2.3.
- Krejci I, Reich T, Lutz F, Albertoni M. [An in vitro test procedure for evaluating dental restoration systems. 1. A computer-controlled mastication simulator.] *Schweiz Monatsschr Zahnmed* 1990;100:953-60. [German]
- Gere JM, Timoshenko SP. Analysis of stress and strain. In: Mechanics of materials. 3rd ed. Boston: PWS Publishing; 1990. p. 378-460.

Reprint requests to:

DR PASCAL MAGNE
UNIVERSITY OF GENEVA SCHOOL OF DENTAL MEDICINE
19, RUE BARTHÉLEMY-MENN
CH-1205 GENÈVE
SWITZERLAND
FAX: (41)22-372-9497
E-MAIL: pascal.magne@medecine.unige.ch

Copyright © 2002 by The Editorial Council of *The Journal of Prosthetic Dentistry*.
0022-3913/2002/\$35.00 + 0. 10/1/124367

doi:10.1067/mpr.2002.124367