



Thèse

2013

Open Access

This version of the publication is provided by the author(s) and made available in accordance with the copyright holder(s).

---

## On quantization of quasi-Lie bialgebras

---

Sakalos, Stefan

### How to cite

SAKALOS, Stefan. On quantization of quasi-Lie bialgebras. Doctoral Thesis, 2013. doi:  
10.13097/archive-ouverte/unige:34305

This publication URL: <https://archive-ouverte.unige.ch/unige:34305>

Publication DOI: [10.13097/archive-ouverte/unige:34305](https://doi.org/10.13097/archive-ouverte/unige:34305)

UNIVERSITÉ DE GENÈVE    FACULTÉ DES SCIENCES  
Section des Mathématiques    Professeur Pavol Ševera

---

# On Quantization of Quasi-Lie Bialgebras

THÈSE

présentée à la Faculté des Sciences de l'Université de Genève  
pour obtenir le grade de Docteur ès sciences, mention  
mathématiques

par

**Štefan Sakáloš**

de  
Slovaquie

Thèse No. 4630

Genève  
Atelier d'impression ReproMail de l'Université de Genève  
2013



**UNIVERSITÉ  
DE GENÈVE**

**FACULTÉ DES SCIENCES**

**Doctorat ès sciences  
Mention mathématiques**

Thèse de *Monsieur Štefan SAKÁLOŠ*

intitulée :

**" On Quantization of Quasi-Lie Bialgebras "**

La Faculté des sciences, sur le préavis de Messieurs P. ŠEVERA, docteur et directeur de thèse (Section de mathématiques), A. ALEXEEV, professeur ordinaire et codirecteur de thèse (Section de mathématiques) et B. ENRIQUEZ, professeur (Institut de recherche mathématique avancée, Université de Strasbourg, France), autorise l'impression de la présente thèse, sans exprimer d'opinion sur les propositions qui y sont énoncées.

Genève, le 17 décembre 2013

**Thèse - 4630 -**



**Le Doyen, Jean-Marc TRISCONE**

N.B.- La thèse doit porter la déclaration précédente et remplir les conditions énumérées dans les "Informations relatives aux thèses de doctorat à l'Université de Genève".

## CONTENTS

<i>Résumé</i> . . . . .	ii
<i>Acknowledgements</i> . . . . .	iv
<i>Part I Overview</i>	1
1 Hopf algebras . . . . .	2
2 Quasi-Hopf algebras . . . . .	4
3 Quasi-triangular structures . . . . .	9
4 Quantization of Lie bialgebras . . . . .	11
5 Our results . . . . .	12
<i>Part II Article</i>	14

## RÉSUMÉ

Les quasi-bialgèbres furent introduites par Drinfeld dans [1]. Elles généralisent la notion de bialgèbre d'une manière qui garantit que la catégorie des modules est toujours une catégorie monoïdale. La structure additionnelle d'une quasi-bialgèbre quasi-triangulaire produit un tressage sur la catégorie des modules. Drinfeld a aussi défini une algèbre enveloppante quantifiée quasi-Hopf comme une déformation d'une algèbre enveloppante  $\mathcal{U}\mathfrak{g}$  dans la catégorie des quasi-bialgèbres. Une telle algèbre enveloppante quantifiée quasi-Hopf  $H$  induit sur  $\mathfrak{g}$  la structure d'une quasi-bialgèbre de Lie, appelée la limite classique de  $H$ .

Dans un autre article [2] Drinfeld a construit des associateurs comme un moyen qui lui a permis de quantifier une algèbre de Lie  $\mathfrak{g}$  avec un élément invariant  $t \in S^2\mathfrak{g}$  et obtenir comme résultat une algèbre enveloppante quantifiée quasi-Hopf quasi-triangulaire.

Etingof et Kazhdan [4] ont utilisé les résultats de Drinfeld pour obtenir une quantification des bialgèbres de Lie en algèbres enveloppantes quantifiées de Hopf.

Finalement, Enriquez et Halbout [3] ont comparé le PROP de bialgèbres de Lie avec le PROP de quasi-bialgèbres de Lie, ce qui leur a permis de réduire le problème de quantification de quasi-bialgèbres de Lie au problème déjà résolu par Etingof et Kazhdan.

Dans cette thèse nous allons décrire une autre méthode de quantification de quasi-bialgèbres de Lie basée sur une généralisation de la construction de Etingof et Kazhdan. On peut résumer notre procédé comme suit. Soient  $\mathfrak{g}$  la quasi-bialgèbre de Lie que l'on veut quantifier et  $\mathfrak{p}$  son double de Drinfeld. Dénotons par  $\mathcal{G}$  et  $\mathcal{P}$  les catégories de leurs modules à gauche. La construction peut être décomposée en deux pas :

1. Nous encodons la bialgèbre commutative  $\mathcal{U}\mathfrak{g}$  comme la bialgèbre des endomorphismes d'un certain foncteur qui est construit seulement en utilisant la catégorie  $\mathcal{P}$  et certains de ses objets.

Pour commencer, on peut regarder  $\mathcal{U}\mathfrak{g}$  comme la bialgèbre des endomorphismes du foncteur d'oubli  $F : \mathcal{G} \rightarrow \mathbf{Vec}$ . Notons que  $F$  peut être représenté par l'objet  $C := \mathcal{U}\mathfrak{g} \in \text{ob}(\mathcal{G})$ . On peut construire une algèbre commutative  $A$  dans  $\mathcal{P}$ , former la catégorie  $\mathcal{A}$  des  $A$ -modules dans  $\mathcal{P}$  et trouver une (presque) équivalence de catégories

$$\tilde{\heartsuit} : \mathcal{G} \rightarrow \mathcal{A}.$$

Par conséquent,  $\mathcal{U}\mathfrak{g}$  est isomorphe à la bialgèbre des endomorphismes du foncteur  $\mathbf{h} : \mathcal{A} \rightarrow \mathbf{Vec}$  représenté par  $\tilde{\heartsuit}C$ .

2. Nous appliquons un associateur.

$\mathcal{P}$  est une catégorie monoïdale infinitésimalement tressée, donc si on applique un associateur  $\Phi$ , on obtient une véritable structure de catégorie monoïdale tressée. Dénoteons la par  $\mathcal{P}^\Phi$ . Comme  $A$  était infinitésimalement commutative dans  $\mathcal{P}$ , elle va aussi devenir une algèbre commutative dans  $\mathcal{P}^\Phi$ . On peut donc toujours former la catégorie  $\mathcal{A}^\Phi$  des  $A$ -modules dans  $\mathcal{P}^\Phi$ . Après quelques difficultés on peut construire de nouveau un foncteur représenté  $\mathbf{h}^\Phi : \mathcal{A}^\Phi \rightarrow \mathbf{Vec}$  analogue à  $\mathbf{h}$ . Donc finalement nous sommes dans la situation similaire à celle du point (1) et nous pouvons obtenir notre quantification comme la quasi-bialgèbre des endomorphismes du foncteur  $\mathbf{h}^\Phi$ .

## ACKNOWLEDGEMENTS

I must thank to the people from the math department of the University of Geneva for creating excellent working conditions and especially to Professor Anton Alekseev who admitted me to his working group and organized my funding.

The money was kindly provided by the University of Geneva, the ProDoc program “Geometry, Algebra and Mathematical Physics” and the grant PD-FMP2.137071 of the Swiss National Science Foundation.

But foremost, my thanks are due to my supervisor Pavol Ševera for sharing his mathematical and spiritual wisdom, for his friendship and for his patience. And also for his company in the darkness, cold and wind of treacherous mountains.

Part I

OVERVIEW

## 1 Hopf algebras

### 1.1 Motivation

Definition of Hopf algebras can be seen as a reformulation of a notion of a group so that it would make sense in the category of vector spaces (or in any symmetric monoidal category). Recall that a group is an object  $G$  in the monoidal category  $(\mathbf{Set}, \times, *)$  equipped with three maps

$$\mu : G \times G \rightarrow G, \quad \eta : * \rightarrow G, \quad S : G \rightarrow G$$

that satisfy the following conditions

1.  $(G, \mu, \eta)$  is a monoid in  $(\mathbf{Set}, \times, *)$  i.e.

$$\mu \circ (\text{id}_G \times \mu) = \mu \circ (\mu \times \text{id}_G)$$

$$\mu \circ (\text{id}_G \times \eta) = \text{id}_G = \mu \circ (\eta \times \text{id}_G)$$

2.  $S$  gives inverse elements:

$$\mu \circ (S \times \text{id}_G) \circ \Delta = \eta \circ \varepsilon = \mu \circ (\text{id}_G \times S) \circ \Delta .$$

Here we needed the diagonal map and the unique map to the terminal object

$$\Delta : G \rightarrow G \times G, \quad \varepsilon : G \rightarrow *$$

which come for free with any object of  $\mathbf{Set}$ . In other words, in  $(\mathbf{Set}, \times, *)$  any object  $G$  has a unique comonoid structure  $(G, \Delta, \varepsilon)$  and any morphism in  $\mathbf{Set}$  is a homomorphism of comonoids. This is not true in  $(\mathbf{Vec}, \otimes, \mathbb{K})$  where we need to make  $\Delta$  and  $\varepsilon$  an explicit part of the structure.

### 1.2 Definition

A *bialgebra* is a vector space  $H$  equipped with linear maps

$$\mu : H \otimes H \rightarrow H, \quad \eta : \mathbb{K} \rightarrow H$$

$$\Delta : H \rightarrow H \otimes H, \quad \varepsilon : H \rightarrow \mathbb{K}$$

satisfying that

1.  $(H, \mu, \eta)$  is an associative algebra,
2.  $(H, \Delta, \varepsilon)$  is a coassociative coalgebra,
3.  $\mu$  and  $\eta$  are coalgebra homomorphisms, or equivalently,  $\Delta, \varepsilon$  are algebra homomorphisms.

It is a *Hopf algebra* if there is also a linear map

$$S : H \rightarrow H$$

satisfying

$$(4) \quad \mu \circ (S \otimes \text{id}_H) \circ \Delta = \eta \circ \varepsilon = \mu \circ (\text{id}_H \otimes S) \circ \Delta .$$

It turns out that  $S$  is an anti-homomorphism of both algebra and coalgebra structures on  $H$ .

### 1.3 Example: Universal enveloping algebra

Let  $\mathfrak{g}$  be a Lie algebra. The universal enveloping algebra  $\mathcal{U}\mathfrak{g}$  is a Hopf algebra once we take

$$\Delta : \mathcal{U}\mathfrak{g} \rightarrow \mathcal{U}\mathfrak{g} \otimes \mathcal{U}\mathfrak{g}, \quad \varepsilon : \mathcal{U}\mathfrak{g} \rightarrow \mathbb{K}, \quad S : \mathcal{U}\mathfrak{g} \rightarrow \mathcal{U}\mathfrak{g}$$

to be the unique algebra (anti-)homomorphisms satisfying for all  $x \in \mathfrak{g}$

$$\Delta(x) = x \otimes 1 + 1 \otimes x, \quad \varepsilon(x) = 0, \quad S(x) = -x.$$

Note that  $\Delta$  is co-commutative.

### 1.4 Quantized universal enveloping algebras

We can consider Hopf algebras in any symmetric monoidal category, in particular in the category of topologically free  $\mathbb{K}[[\hbar]]$ -modules with the completed tensor product  $\hat{\otimes}_{\mathbb{K}[[\hbar]]}$ . Such a Hopf algebra  $H$  is called a *quantized universal enveloping (QUE) algebra* if  $H/\hbar H$  is isomorphic as a Hopf algebra to  $\mathcal{U}\mathfrak{g}$  for some Lie algebra  $\mathfrak{g}$ .

*Remark 1.1.* Actually, any topologically free bialgebra  $H$  over  $\mathbb{K}[[\hbar]]$  that is a deformation of  $\mathcal{U}\mathfrak{g}$  (i.e.  $H/\hbar H \cong \mathcal{U}\mathfrak{g}$  as a bialgebra) is automatically a Hopf algebra. See e.g. Proposition 8.5.in [5].

### 1.5 Lie bialgebras

Let  $\mathfrak{g}$  be a Lie algebra. If  $H$  is a QUE algebra s.t.  $H/\hbar H \cong \mathcal{U}\mathfrak{g}$  then we get on  $\mathfrak{g}$  another operation

$$\delta : \mathfrak{g} \rightarrow \mathfrak{g} \otimes \mathfrak{g} : x \mapsto \frac{\Delta(\tilde{x}) - \Delta^{op}(\tilde{x})}{\hbar} \pmod{\hbar} \quad (1.1)$$

where we denoted by  $\tilde{x}$  whatever element of  $H$  satisfying  $\tilde{x} \equiv x \pmod{\hbar}$  and where  $\Delta^{op}$  is the composition

$$\Delta^{op} : H \xrightarrow{\Delta} H \hat{\otimes}_{\mathbb{K}[[\hbar]]} H \xrightarrow{a \otimes b \mapsto b \otimes a} H \hat{\otimes}_{\mathbb{K}[[\hbar]]} H .$$

One can show that  $\delta$  is well defined i.e. that it does not depend on the choice of  $\tilde{x}$  and that really  $\delta(x) \in \mathfrak{g} \otimes \mathfrak{g}$ . Moreover  $(\mathfrak{g}, [\cdot, \cdot], \delta)$  is a Lie bialgebra from the following definition.

**Definition 1.2.** A vector space  $\mathfrak{g}$  with two operations

$$[\cdot, \cdot] : \mathfrak{g} \otimes \mathfrak{g} \rightarrow \mathfrak{g}, \quad \delta : \mathfrak{g} \rightarrow \mathfrak{g} \otimes \mathfrak{g}$$

is a *Lie bialgebra* if it satisfies

1.  $(\mathfrak{g}, [\cdot, \cdot])$  is a Lie algebra,
2.  $(\mathfrak{g}, \delta)$  is a Lie coalgebra,

3.  $[\cdot, \cdot]$  and  $\delta$  are compatible in the sense that  $\delta$  is a 1-cocycle on  $\mathfrak{g}$  with the coefficients in  $\mathfrak{g} \otimes \mathfrak{g}$ , i.e.

$$\delta[x, y] = [x \otimes 1 + 1 \otimes x, \delta(y)] - [y \otimes 1 + 1 \otimes y, \delta(x)]$$

If  $H$  is a QUE algebra with  $H/\hbar H \cong \mathcal{U}\mathfrak{g}$  and  $\delta$  is defined by (1.1) then the bialgebra  $(\mathfrak{g}, [\cdot, \cdot], \delta)$  is called the classical limit of  $H$  and conversely  $H$  is called a quantization of  $(\mathfrak{g}, [\cdot, \cdot], \delta)$ . The question whether any Lie bialgebra can be quantized was answered positively by Etingof and Kazhdan in [4].

### 1.6 Double Lie bialgebra

There is a nice way to encode a Lie bialgebra  $(\mathfrak{g}, [\cdot, \cdot], \delta)$  which we shall now describe. On the vector space  $\mathfrak{p} := \mathfrak{g} \oplus \mathfrak{g}^*$  we have a canonical scalar product  $\langle \cdot, \cdot \rangle_{\mathfrak{p}}$  given by the pairing between  $\mathfrak{g}$  and  $\mathfrak{g}^*$ . We can regard  $\delta$  as a Lie algebra bracket  $\delta : \mathfrak{g}^* \otimes \mathfrak{g}^* \rightarrow \mathfrak{g}^*$  on  $\mathfrak{g}^*$ . It turns out that there exists a unique Lie algebra bracket on  $\mathfrak{p}$  satisfying

1.  $\mathfrak{g}, \mathfrak{g}^*$  are Lie sub-algebras of  $\mathfrak{p}$  and
2.  $\langle \cdot, \cdot \rangle_{\mathfrak{p}}$  is an invariant scalar product on  $\mathfrak{p}$ .

Conversely, let's have a Lie algebra bracket  $[\cdot, \cdot]_{\mathfrak{p}}$  on  $\mathfrak{p} = \mathfrak{g} \oplus \mathfrak{g}^*$  satisfying (1) and (2) above. One can read  $[\cdot, \cdot]$  and  $\delta$  as restrictions of  $[\cdot, \cdot]_{\mathfrak{p}}$  to  $\mathfrak{g}$  and  $\mathfrak{g}^*$  respectively and show that  $(\mathfrak{g}, [\cdot, \cdot], \delta)$  form a Lie bialgebra.

## 2 Quasi-Hopf algebras

Everything in this section is from [1].

### 2.1 Motivation

If  $H$  is a bialgebra then the category  $H\text{-Mod}$  of its left modules is a strict monoidal category. Really, if  $M, N \in H\text{-Mod}$  then  $M \otimes N$  is also an  $H$ -module via:

$$x \triangleright (m \otimes n) := \sum (x_{(1)} \triangleright m) \otimes (x_{(2)} \triangleright n)$$

where we used the Sweedler notation  $\Delta(x) = \sum x_{(1)} \otimes x_{(2)}$ . The augmentation  $\varepsilon : H \rightarrow \mathbb{K}$  gives the  $H$ -module structure on the identity object  $\mathbb{K}$ . All the axioms of a bialgebra are needed when checking that we get indeed a strict monoidal category. For instance, the co-associativity of  $\Delta$  ensures that the associativity morphism given by the identity map

$$(L \otimes M) \otimes N \xrightarrow{\text{id}} L \otimes (M \otimes N)$$

is a homomorphism of  $H$ -modules.

The idea of Drinfeld was to relax the definition of a bialgebra in a way that the corresponding category of modules would be a non-strict monoidal

category. This means adding an element  $\Phi \in H \otimes H \otimes H$  that will determine the associativity morphisms in  $H\text{-Mod}$  as

$$(L \otimes M) \otimes N \xrightarrow{\Phi \triangleright} (L \otimes M) \otimes N \xrightarrow{\text{id}} L \otimes (M \otimes N). \quad (2.1)$$

## 2.2 Definition of quasi-bialgebras

**Definition 2.1.** A *quasi-bialgebra* is an associative algebra  $H$  together with algebra morphisms  $\Delta : H \rightarrow H \otimes H$ ;  $\varepsilon : H \rightarrow \mathbb{K}$  and an invertible element  $\Phi \in H \otimes H \otimes H$  satisfying

$$(\text{id} \otimes \Delta) \circ \Delta(a) = \Phi \cdot [(\Delta \otimes \text{id}) \circ \Delta(a)] \cdot \Phi^{-1} \quad (2.2)$$

$$(\text{id} \otimes \text{id} \otimes \Delta)(\Phi) \cdot (\Delta \otimes \text{id} \otimes \text{id})(\Phi) = (1 \otimes \Phi) \cdot (\text{id} \otimes \Delta \otimes \text{id})(\Phi) \cdot (\Phi \otimes 1) \quad (2.3)$$

$$(\varepsilon \otimes \text{id}) \circ \Delta = \text{id}; \quad (\text{id} \otimes \varepsilon) \circ \Delta = \text{id} \quad (2.4)$$

$$(\text{id} \otimes \varepsilon \otimes \text{id})\Phi = 1 \otimes 1 \quad (2.5)$$

*Remark 2.2.* We need (2.2) to have  $H$ -linearity of (2.1), (2.3) ensures the pentagon axiom of the monoidal category  $H\text{-Mod}$ , (2.4) implies that  $\mathbb{K}$  is the unit object and (2.5) is responsible for another axiom of a monoidal category (with a strict unit object), i.e commutativity of

$$\begin{array}{ccc} (M \otimes \mathbb{K}) \otimes N & \xrightarrow{\Phi} & M \otimes (\mathbb{K} \otimes N) \\ & \searrow = & \swarrow = \\ & & M \otimes N \end{array}$$

## 2.3 Definition of quasi-Hopf algebras

**Definition 2.3.** A quasi-Hopf algebra has in addition to the structure described in Definition 2.1 an algebra anti-automorphism  $S : H \rightarrow H$  and two elements  $\alpha, \beta \in H$  satisfying

$$(S(a_{(1)})) \cdot \alpha \cdot a_{(2)} = \varepsilon(a) \cdot \alpha \quad (2.6)$$

$$a_{(1)} \cdot \beta \cdot (S(a_{(2)})) = \varepsilon(a) \cdot \beta \quad (2.7)$$

$$\Phi^1 \cdot \beta \cdot S(\Phi^2) \cdot \alpha \cdot \Phi^3 = 1 \quad (2.8)$$

$$S(\phi^1) \cdot \alpha \cdot \phi^2 \cdot \beta \cdot S(\phi^3) = 1 \quad (2.9)$$

Here we denoted  $\Phi =: \Phi^1 \otimes \Phi^2 \otimes \Phi^3$  and  $\Phi^{-1} =: \phi^1 \otimes \phi^2 \otimes \phi^3$  and we don't write sums  $\sum$ .

*Remark 2.4.* The motivation for this definition is the following. If  $H$  is a Hopf algebra with invertible  $S$  then the category of finite dimensional modules is rigid. Really, any finite dimensional  $H$ -module  $M$  has a left dual  ${}^*M$  and a

right dual  $M^*$  that are both equal to  $\mathbf{Vec}(M, \mathbb{K})$  as vector spaces and whose  $H$ -module structures are defined by

$$(x \triangleright f)(m) := f(Sx \triangleright m), \quad \text{for } x \in H, f \in {}^*M, m \in M;$$

$$(x \triangleright g)(m) := g(S^{-1}x \triangleright m), \quad \text{for } x \in H, g \in M^*, m \in M.$$

A quasi-Hopf algebra structure on  $H$  still ensures that the category of finite dimensional modules will be rigid.

#### 2.4 Recovering a (quasi) bialgebra from the forgetful functor

$$H\text{-Mod} \xrightarrow{\text{forg}} \mathbf{Vec}$$

Since all the axioms in the definition of a quasi-bialgebra are needed to ensure that  $H\text{-Mod}$  is a strict monoidal category, one would expect that we can recover  $H$  from  $H\text{-Mod}$ . This is not quite true, however we can recover  $H$  from the functor  $H\text{-Mod} \xrightarrow{\text{forg}} \mathbf{Vec}$  as its algebra of endomorphisms. The coproduct on  $H$  can be restored from the strong quasi-monoidal structure on the functor  $\text{forg}$  as we shall now describe.

**Definition 2.5.**<sup>1</sup> A *strong quasi-monoidal structure* on a functor  $F : \mathcal{C} \rightarrow \mathcal{V}$  between two monoidal categories is a natural isomorphism

$$\begin{array}{ccc} \mathcal{C} \times \mathcal{C} & \xrightarrow{\otimes} & \mathcal{C} \\ \downarrow F \times F & \lambda \nearrow & \downarrow F \\ \mathcal{V} \times \mathcal{V} & \xrightarrow{\otimes} & \mathcal{V} \end{array} \quad (2.10)$$

If  $H$  is a quasi-bialgebra then the identity map

$$\text{forg}(M) \otimes \text{forg}(N) \xrightarrow{\text{id}} \text{forg}(M \otimes N)$$

turns  $H\text{-Mod} \xrightarrow{\text{forg}} \mathbf{Vec}$  into a strong quasi-monoidal functor. If  $H$  is a bialgebra then  $\text{forg}$  will be strong monoidal.

**Claim 2.6.**<sup>2</sup> If  $\mathcal{C}$  is a category enriched over  $\mathcal{V} := \mathbf{Vec}$  and

$$\mathbf{h}_C : \mathcal{C} \rightarrow \mathcal{V} : X \mapsto \mathcal{C}(C, X)$$

the functor represented by an object  $C \in \mathcal{C}$ , then the natural map

$$\text{End}(\mathcal{C} \xrightarrow{\mathbf{h}_C} \mathcal{V}) \otimes \text{End}(\mathcal{C} \xrightarrow{\mathbf{h}_C} \mathcal{V}) \longrightarrow \text{End}(\mathcal{C} \times \mathcal{C} \xrightarrow{\mathbf{h}_C \times \mathbf{h}_C} \mathcal{V} \times \mathcal{V} \xrightarrow{\otimes} \mathcal{V}) \quad (2.11)$$

is an isomorphism.

1. This is not a complete definition — we need a nice behavior w.r.t. the unit object. See Definition 5.1. in [6].

2. See Lemma 5.5 of [6].

**Corollary 2.7.** *Let  $\mathcal{C}$  be a monoidal category enriched over  $\mathcal{V} := \mathbf{Vec}$  and let  $F : \mathcal{C} \rightarrow \mathcal{V}$  be a represented functor with a strong quasi-monoidal structure. Then  $H := \text{End}(F)$  is a quasi-bialgebra.*

*If  $F$  is strong monoidal then  $H$  is a bialgebra.*

*Proof.* An endomorphism  $\gamma$  of  $F$  induces an endomorphism  $\gamma_*$  of  $\mathcal{C} \times \mathcal{C} \xrightarrow{\otimes} \mathcal{C} \xrightarrow{F} \mathcal{V}$  and thus (see (2.10)) an endomorphism  $\lambda^{-1} \circ \gamma_* \circ \lambda$  of  $\mathcal{C} \times \mathcal{C} \xrightarrow{F \times F} \mathcal{V} \times \mathcal{V} \xrightarrow{\otimes} \mathcal{V}$ . This gives a map

$$\text{End}(\mathcal{C} \xrightarrow{F} \mathcal{V}) \longrightarrow \text{End}(\mathcal{C} \times \mathcal{C} \xrightarrow{F \times F} \mathcal{V} \times \mathcal{V} \xrightarrow{\otimes} \mathcal{V})$$

We compose it with the inverse of the isomorphism (2.11) to get our  $\Delta$ . One can also define  $\Phi \in H \otimes H \otimes H$  and check that everything works — see Lemma 5.2 in [6].  $\square$

## 2.5 Twists

Any invertible element<sup>3</sup>  $J \in H \otimes H$  defines a new quasi-monoidal structure on the forgetful functor  $H\text{-Mod} \rightarrow \mathbf{Vec}$  by

$$\text{forg}(M) \otimes \text{forg}(N) \xrightarrow{J \triangleright} \text{forg}(M \otimes N).$$

The corollary 2.7 then defines a new structure of a quasi-bialgebra on the same algebra  $H = \text{End}(H\text{-Mod} \xrightarrow{\text{forg}} \mathbf{Vec})$ . Algebraically:

$$\tilde{\Delta}(a) = F \cdot \Delta(a) \cdot F^{-1}, \quad \forall a \in A \quad (2.12)$$

$$\tilde{\Phi} = F^{23} \cdot (\text{id} \otimes \Delta)(F) \cdot \Phi \cdot (\Delta \otimes \text{id})(F^{-1}) \cdot (F^{12})^{-1} \quad (2.13)$$

## 2.6 Quasi-Hopf QUE algebras

Quasi-Hopf QUE<sup>4</sup> algebra is a topological quasi-bialgebra  $(H, \Delta, \varepsilon, \Phi)$  over  $\mathbb{K}[[\hbar]]$  s.t.

1.  $\Phi \equiv 1 \pmod{\hbar}$ ;
2.  $H/\hbar H$  is a universal enveloping algebra;
3.  $H$  is a topologically free  $\mathbb{K}[[\hbar]]$ -module;
4.  $\text{Alt } \Phi \equiv 0 \pmod{\hbar^2}$ .

*Remark 2.8.* Drinfeld shows that a Quasi-Hopf QUE algebra can be twisted by an element  $J \in H \hat{\otimes}_{\mathbb{K}[[\hbar]]} H$ ;  $J \equiv 1 \pmod{\hbar}$  into a form where

$$\Phi \equiv 1 \pmod{\hbar^2}. \quad (2.14)$$

From now on we suppose that our quasi-Hopf QUE algebras satisfy (2.14) and we use just the twists that satisfy  $J \equiv 1 \pmod{\hbar}$  and that preserve (2.14).

*Remark 2.9.* Drinfeld also shows that a quasi-Hopf QUE algebra is automatically a quasi-Hopf algebra.

---

3. Actually one requires also  $(\text{id} \otimes \varepsilon)J = 1 = (\varepsilon \otimes \text{id})J$ .  
4. QUE = quantum universal enveloping

### 2.7 Quasi-Lie bialgebras

A quasi-Hopf QUE algebra  $H$  s.t  $H/\hbar H \cong \mathcal{U}\mathfrak{g}$  gives rise to further algebraic structure on the Lie algebra  $\mathfrak{g}$ . Namely, if we define  $\varphi \in \wedge^3 \mathfrak{g}$ ,  $\delta : \mathfrak{g} \rightarrow \wedge^2 \mathfrak{g}$  by the formulas

$$\varphi := \frac{1}{\hbar^2} \cdot \text{Alt}(\Phi) \pmod{\hbar}, \quad (2.15)$$

$$\delta(x) := \frac{1}{\hbar} (\Delta(x) - \Delta^{op}(x)) \pmod{\hbar}. \quad (2.16)$$

Then  $(\mathfrak{g}, [, ], \delta, \varphi)$  is a quasi-Lie bialgebra.

**Definition 2.10.** A *quasi-Lie bialgebra* is a vector space  $\mathfrak{g}$  together with linear maps  $[, ] : \wedge^2 \mathfrak{g} \rightarrow \mathfrak{g}$ ,  $\delta : \mathfrak{g} \rightarrow \wedge^2 \mathfrak{g}$  and an element  $\varphi \in \wedge^3 \mathfrak{g}$  that satisfy

1.  $(\mathfrak{g}, [, ])$  is a Lie-algebra;
2.  $\delta$  is a 1-cocycle  $\delta : \mathfrak{g} \rightarrow \wedge^2 \mathfrak{g}$ ;
3.  $\frac{1}{2} \text{Alt}(\delta \otimes \text{id})\delta(x) = [x \otimes 1 \otimes 1 + 1 \otimes x \otimes 1 + 1 \otimes 1 \otimes x, \varphi] \quad \forall x \in \mathfrak{g}$ ;
4.  $\text{Alt}(\delta \otimes \text{id} \otimes \text{id})(\varphi) = 0$ .

If  $H$  is a quasi-Hopf QUE algebra with  $H/\hbar H \cong \mathcal{U}\mathfrak{g}$  and  $\varphi, \delta$  are defined by (2.15), (2.16) then the quasi-Lie bialgebra  $(\mathfrak{g}, [, ], \delta, \varphi)$  is called the classical limit of  $H$ . Conversely,  $H$  is called a quantization of  $(\mathfrak{g}, [, ], \delta, \varphi)$ .

The question whether any quasi-Lie bialgebra can be quantized was answered positively by Enriquez and Halbout in [3].

### 2.8 Twisting of quasi-Lie bialgebras

If  $(\mathfrak{g}, [, ], \delta, \varphi)$  is a quasi-Lie bialgebra and  $f \in \wedge^2 \mathfrak{g}$  then we get a new quasi-Lie bialgebra structure  $(\mathfrak{g}, [, ], \tilde{\delta}, \tilde{\varphi})$  on the same Lie algebra  $(\mathfrak{g}, [, ])$  by taking

$$\tilde{\delta}(x) := \delta(x) + [x \otimes 1 + 1 \otimes x, f]; \quad (2.17)$$

$$\tilde{\varphi} = \varphi + \frac{1}{2} \text{Alt}(\delta \otimes \text{id})f - \text{CYB}(f) \quad (2.18)$$

where

$$\text{CYB}(f) := [f^{12}, f^{13}] + [f^{12}, f^{23}] + [f^{13}, f^{23}].$$

The motivation for this definition is the following. Let's twist a quasi-Hopf QUE algebra  $(H, \mu, \Delta, \Phi)$  by an invertible element<sup>5</sup>  $J \in H \hat{\otimes}_{\mathbb{K}[[\hbar]]} H$  to a new  $(H, \mu, \tilde{\Delta}, \tilde{\Phi})$ . Then the classical limit of  $(H, \mu, \tilde{\Delta}, \tilde{\Phi})$  can be obtained by twisting the classical limit of  $(H, \mu, \Delta, \Phi)$  by the element

$$f = -\frac{1}{\hbar} \cdot \text{Alt}(J) \pmod{\hbar}.$$

5. Recall our conventions from Remark 2.8

## 2.9 Double of a quasi-Lie bialgebra

Let  $(\mathfrak{g}, [, ], \delta, \varphi)$  be a quasi-Lie bialgebra. One can regard  $\delta$  and  $\varphi$  as maps

$$\delta : \mathfrak{g}^* \otimes \mathfrak{g}^* \rightarrow \mathfrak{g}^*; \quad \varphi : \mathfrak{g}^* \otimes \mathfrak{g}^* \rightarrow \mathfrak{g}. \quad (2.19)$$

As in Subsection 1.6, we will define a Lie algebra structure on  $\mathfrak{p} = \mathfrak{g} \oplus \mathfrak{g}^*$  as the unique Lie bracket  $[, ]$  satisfying

1.  $[, ]_{\mathfrak{p}}$  restricted to  $\mathfrak{g} \otimes \mathfrak{g}$  is  $[, ]_{\mathfrak{g}}$ ,
2.  $[, ]_{\mathfrak{p}}$  restricted to  $\mathfrak{g}^* \otimes \mathfrak{g}^*$  is equal to  $\delta + \varphi$ ,
3.  $\langle \cdot, \cdot \rangle_{\mathfrak{p}}$  is an invariant scalar product on  $\mathfrak{p}$ .

Conversely, let's have a vector space  $\mathfrak{g}$  and a Lie bracket  $[, ]_{\mathfrak{p}}$  on  $\mathfrak{p} = \mathfrak{g} \oplus \mathfrak{g}^*$  that satisfy that  $\mathfrak{g}$  is a Lie subalgebra of  $\mathfrak{p}$  and that  $\langle \cdot, \cdot \rangle_{\mathfrak{p}}$  is an invariant scalar product on  $\mathfrak{p}$ . Then we define a Lie bracket  $[, ]$  on  $\mathfrak{g}$  as the restriction of  $[, ]_{\mathfrak{p}}$ . We also take  $\varphi, \delta$  as in (2.19) to be the unique maps satisfying that  $[, ]_{\mathfrak{p}}$  restricted to  $\mathfrak{g}^* \otimes \mathfrak{g}^*$  is equal to  $\delta + \varphi$ . One can show that  $(\mathfrak{g}, [, ], \delta, \varphi)$  form a quasi-Lie bialgebra.

## 3 Quasi-triangular structures

### 3.1 $R$ -matrix

A quasi-triangular structure on a quasi-bialgebra  $H$  corresponds to a braided structure on the category  $H\text{-Mod}$ .

**Definition 3.1.**  $R$ -matrix is an invertible element  $R \in H \otimes H$  satisfying<sup>6</sup>

$$\Delta^{op}(a) = R \cdot \Delta(a) \cdot R^{-1}, \quad \forall a \in A \quad (3.1)$$

$$(\Delta \otimes \text{id})(R) = \Phi^{312} \cdot R^{13} \cdot (\Phi^{132})^{-1} \cdot R^{23} \cdot \Phi \quad (3.2)$$

$$(\text{id} \otimes \Delta)(R) = (\Phi^{231})^{-1} \cdot R^{13} \cdot \Phi^{213} \cdot R^{12} \cdot \Phi^{-1} \quad (3.3)$$

Given an  $R$ -matrix, we get a braiding on  $H\text{-Mod}$ , i.e. a natural transformation

$$M \otimes N \xrightarrow{R_{\triangleright}} M \otimes N \xrightarrow{\tau} N \otimes M, \quad M, N \in H\text{-Mod}$$

where  $\tau : M \otimes N \rightarrow N \otimes M : m \otimes n \mapsto n \otimes m$ . The condition (3.1) ensures that this map is  $H$ -linear and (3.2), (3.3) are responsible for the hexagon axioms of the braided monoidal category.

Conversely, given a braiding  $\sigma : M \otimes N \rightarrow N \otimes M$  in  $H\text{-Mod}$ , we can define a natural map in  $\mathbf{Vec}$ :

$$FM \otimes FN \xrightarrow{\cong} F(M \otimes N) \xrightarrow{F\sigma} F(N \otimes M) \xrightarrow{\cong} FN \otimes FM \xrightarrow{\tau} FM \otimes FN$$

where  $F$  is the forgetful functor. By Claim 2.6 this natural map corresponds to an element  $R \in \text{End}(F) \otimes \text{End}(F) = H \otimes H$ .

---

6.  $(a \otimes b \otimes c)^{312} = b \otimes c \otimes a$

### 3.2 Twisting

As in the subsection 2.5 we can use  $J \in H \otimes H$  to change the quasi-monoidal structure on the forgetful functor. This yields a new quasi-triangular quasi-bialgebra  $(H, \mu, \tilde{\Delta}, \tilde{\Phi}, \tilde{R})$  with

$$\tilde{R} = F^{21} \cdot R \cdot F^{-1}$$

### 3.3 Quasi-triangular quasi-Hopf QUE algebras and classical limits

If  $H$  is a quasi-Hopf QUE algebra then one considers only  $R$ -matrices satisfying  $R \equiv 1 \pmod{\hbar}$ . Drinfeld shows

**Proposition 3.2.** *Let  $(H, \Delta, \Phi, R)$  be a quasi-triangular quasi-Hopf QUE algebra s.t.  $H/\hbar H = \mathcal{U}\mathfrak{g}$ . Define  $t \in \mathcal{U}\mathfrak{g} \otimes \mathcal{U}\mathfrak{g}$  as*

$$t := \frac{1}{\hbar}(R^{21} \cdot R - 1) \pmod{\hbar}.$$

*Then  $t$  is a  $\mathfrak{g}$ -invariant element of  $S^2\mathfrak{g}$  and does not depend on twisting. Moreover  $H$  can be twisted to obtain*

$$R = 1 + \frac{\hbar}{2}t + o(\hbar), \quad \Phi = 1 + o(\hbar). \quad (3.4)$$

*If  $R, \Phi$  are of this form then  $\Delta, \Phi$  satisfy*

$$\frac{1}{\hbar^2}\text{Alt}(\Phi) \equiv \frac{1}{4}[t^{12}, t^{23}] \pmod{\hbar}; \quad (3.5)$$

$$\Delta \equiv \Delta^{op} \pmod{\hbar^2}. \quad (3.6)$$

One calls the pair  $(\mathfrak{g}, t)$  from the above proposition the classical limit of the quasi-triangular quasi-Hopf QUE algebra  $H$ . Conversely, if  $\mathfrak{g}$  is a Lie algebra and  $t \in S^2\mathfrak{g}$  is  $\mathfrak{g}$ -invariant then by a quantization of the pair  $(\mathfrak{g}, t)$  we mean a quasi-triangular quasi-Hopf QUE algebra  $H$  satisfying (3.4).

*Remark 3.3.* Note that if  $H$  is a quasi-triangular quasi-Hopf QUE algebra satisfying (3.4) then the equations (3.5), (3.6) tell us that the classical limit of  $H$  in the sense of Subsection 2.7 is the quasi-Lie bialgebra

$$(\mathfrak{g}, [, ], \delta, \varphi) \quad \text{where } \delta = 0, \quad \varphi = \frac{1}{4}[t^{12}, t^{23}]. \quad (3.7)$$

We will call 3.7 the *quasi-Lie bialgebra associated to the pair  $(\mathfrak{g}, t)$* .

### 3.4 Drinfeld's quantization

The question whether any  $(\mathfrak{g}, t)$  can be quantized into a quasi-triangular quasi-Hopf QUE algebra was answered by Drinfeld in [2]. He found an explicit expression <sup>7</sup>  $\Phi(X, Y) \in \mathbb{K}\langle\langle X, Y \rangle\rangle$  called an associator, such that a quantization

7. By  $\mathbb{K}\langle\langle X, Y \rangle\rangle$  we denote the ring of formal power series in two non-commuting variables  $X, Y$ .

$(H, \mu, \Delta, \Phi, R)$  of a given  $(\mathfrak{g}, t)$  can be constructed as follows.  $(H, \mu, \Delta)$  are the same as for  $\mathcal{U}\mathfrak{g}[[\hbar]] := \mathcal{U}\mathfrak{g} \hat{\otimes} \mathbb{K}[[\hbar]]$  and  $\Phi, R$  are

$$R := \exp\left(\frac{\hbar t}{2}\right); \quad \Phi := \Phi(\hbar t_{12}, \hbar t_{23})$$

where  $t_{12} = t \otimes 1$ ,  $t_{23} = 1 \otimes t$ .

### 3.5 Double Lie algebra revisited

Let  $(\mathfrak{g}, [, ], \delta, \varphi)$  be a quasi-Lie bialgebra. Recall from Subsection 2.9 that we constructed a Lie algebra  $(\mathfrak{p} = \mathfrak{g} \oplus \mathfrak{g}^*, [, ]_{\mathfrak{p}})$  with the invariant scalar product  $\langle \cdot, \cdot \rangle_{\mathfrak{p}}$  given by the pairing between  $\mathfrak{g}$  and  $\mathfrak{g}^*$ . The inverse of  $\langle \cdot, \cdot \rangle_{\mathfrak{p}}$  is an invariant element  $t \in S^2\mathfrak{p}$ . If  $\{e_i\}$  and  $\{e^i\}$  are dual bases of  $\mathfrak{g}$  and  $\mathfrak{g}^*$  then explicitly

$$t = e_i \otimes e^i + e^i \otimes e_i.$$

As in Remark 3.3, we can construct the associated quasi-Lie bialgebra structure on  $\mathfrak{p}$ :

$$\left(\mathfrak{p}, [, ]_{\mathfrak{p}}, \delta_{\mathfrak{p}} = 0, \varphi_{\mathfrak{p}} = \frac{1}{4}[t^{12}, t^{23}]\right).$$

It would be natural to expect that  $\mathfrak{p}$  contains  $\mathfrak{g}$  as a sub-quasi-Lie bialgebra. This is not possible directly, since  $\delta_{\mathfrak{p}} = 0$ . However, we have

**Proposition 3.4.** *Let's twist  $\mathfrak{p}$  by  $f := \frac{1}{2}(e_i \otimes e^i - e^i \otimes e_i)$  to a new quasi-Lie bialgebra  $\mathfrak{p}' = (\mathfrak{p}, [, ]_{\mathfrak{p}}, \delta_{\mathfrak{p}'}, \varphi_{\mathfrak{p}'})$ . Then  $\mathfrak{g}$  is a sub-quasi-Lie bialgebra of  $\mathfrak{p}'$ .*

*If  $\mathfrak{g}$  is a Lie bialgebra, then so is  $\mathfrak{p}'$ .*

## 4 Quantization of Lie bialgebras

A procedure for constructing a quantization of a Lie bialgebra  $(\mathfrak{g}, [, ], \delta)$  was found by Etingof and Kazhdan in [4].

In Subsections 1.6 and 3.5 we constructed a Lie algebra  $(\mathfrak{p} = \mathfrak{g} \oplus \mathfrak{g}^*, [, ]_{\mathfrak{p}})$  and a  $\mathfrak{p}$ -invariant  $t \in S^2\mathfrak{g}$ . We can quantize  $(\mathfrak{p}, t)$  using the Drinfeld method into a quasi-Hopf QUE algebra  $\mathcal{U}_{\hbar}\mathfrak{p}$ . Etingof and Kazhdan further construct

1. a particular twist  $J$  on  $\mathcal{U}_{\hbar}\mathfrak{p}$  whose classical limit is the twist  $f$  from Proposition 3.4 (we denote the twisted bialgebra by  $\mathcal{U}_{\hbar}\mathfrak{p}'$ ) and
2. a  $\mathbb{K}[[\hbar]]$ -module monomorphism  $\beta : \mathcal{U}\mathfrak{g}[[\hbar]] \rightarrow \mathcal{U}_{\hbar}\mathfrak{p}'$  whose image is a sub-bialgebra of  $\mathcal{U}_{\hbar}\mathfrak{p}'$  and that  $\beta/\hbar : \mathcal{U}\mathfrak{g} \rightarrow \mathcal{U}\mathfrak{p}$  is just the ordinary inclusion.

One can then use  $\beta$  to identify  $\mathcal{U}\mathfrak{g}[[\hbar]]$  with  $\text{Im}(\beta)$  and thus to get a bialgebra structure on  $\mathcal{U}\mathfrak{g}[[\hbar]]$ . We denote it by  $\mathcal{U}_{\hbar}\mathfrak{g}$ . The classical limit of  $\mathcal{U}_{\hbar}\mathfrak{g}$  (which is just  $\mathfrak{g}$  as a vector space) is a sub-Lie bialgebra of the classical limit of  $\mathcal{U}_{\hbar}\mathfrak{p}'$  (which is the Lie bialgebra  $\mathfrak{p}'$ ). The proposition 3.4 then implies that the classical limit of  $\mathcal{U}_{\hbar}\mathfrak{g}$  is indeed  $(\mathfrak{g}, [, ], \delta)$ .

The construction of  $J$  and  $\beta$  can be carried out in the categorical language as described in [4] and generalized in [6].

## 5 *Our results*

In [6] we quantize quasi-Lie bialgebras by a procedure generalizing the methods of Etingof and Kazhdan. Actually, everything said in Section 4 works after replacing “Lie bialgebra” by “quasi-Lie bialgebra”. However in the construction of  $J$  and  $\beta$  one encounters more difficulties. Namely, the object representing a certain functor  $\mathbf{h}$  which encodes our  $\mathcal{U}_{\hbar}\mathfrak{g}$  as  $\mathcal{U}_{\hbar}\mathfrak{g} \cong \text{End}(\mathbf{h})$  is no longer free and we must work with projective modules instead. The reader can find more details in the article itself that forms the rest of this thesis.

Let us remark that quasi-Lie bialgebras were first quantized by Enriquez and Halbout in [3]. Their approach is quite different — they compare the PROP of quasi-Lie bialgebras with the PROP of Lie-bialgebras using cohomological methods in order to reduce their problem to the one already solved by Etingof and Kazhdan.

## BIBLIOGRAPHY

- [1] V. G. Drinfeld: Quasi-Hopf algebras. (Russian) *Algebra i Analiz* 1 (1989), no. 6, 114–148; translation in *Leningrad Math. J.* 1 (1990), no. 6, 1419–1457.
- [2] V. G. Drinfeld: On quasitriangular quasi-Hopf algebras and on a group closely connected with  $\text{Gal}(\overline{\mathbb{Q}}/\mathbb{Q})$ . (Russian) *Algebra i Analiz* 2 (1990), no. 4, 149–181; translation in *Leningrad Math. J.* 2 (1991), no. 4, 829–860.
- [3] B. Enriquez, G. Halbout: Quantization of quasi-Lie bialgebras. *J. Amer. Math. Soc.* 23 (2010), no. 3, 611–653.
- [4] P. Etingof, D. Kazhdan: Quantization of Lie bialgebras. I. *Selecta Math. (N.S.)* 2 (1996), no. 1, 1–41.
- [5] P. Etingof, O. Schiffmann: Lectures on quantum groups. Second edition. *Lectures in Mathematical Physics*. International Press, Somerville, MA, 2002.
- [6] Š. Sakáloš, P. Ševera: On quantization of quasi-Lie bialgebras, arXiv:1304.6382 [math.QA]. Also included in this thesis.

Part II

ARTICLE

# ON QUANTIZATION OF QUASI-LIE BIALGEBRAS

ŠTEFAN SAKÁLOŠ AND PAVOL ŠEVERA

ABSTRACT. We modify the quantization of Etingof and Kazhdan so that it can be used to quantize quasi-Lie bialgebras.

## CONTENTS

1. Introduction	1
2. Our construction in a nutshell	2
3. Notation	7
4. Quasi-bialgebras	9
5. From categories to quasi-bialgebras	13
6. Modules in braided monoidal categories	21
7. Represented functors	23
8. Our categories	24
9. Representing $\mathcal{U}\mathfrak{g}$ as endomorphisms of $\mathbf{h} : \mathcal{F} \rightarrow \mathcal{V}^{\text{cp}}$	29
10. Passing from $\mathbb{K}$ to $\mathbb{K}[[\hbar]]$	32
11. Applying an associator	33
12. The twist	38
13. Putting things together	43
Appendix A. Topological vector spaces	44
Appendix B. Universal enveloping algebra	50
Appendix C. Equicontinuous modules	53
Appendix D. Some properties of $\heartsuit : \mathcal{G} \rightarrow \mathcal{P}$	55
Appendix E. Categories of $\mathbb{K}[[\hbar]]$ -modules	58
References	60

## 1. INTRODUCTION

Quasi-bialgebras were introduced by Drinfeld in [1] as a generalization of bialgebras in such a way that the corresponding category of modules would still be a monoidal category. An additional structure of a quasi-triangular quasi-Hopf algebra produces a braided monoidal category in a similar way. Drinfeld also introduced quasi-Hopf universal enveloping algebras as deformations of the universal enveloping algebra of Lie algebras in the category of quasi-bialgebras and quasi-Lie bialgebras as their classical limits. In the subsequent paper [2] he introduced associators as a

---

Štefan Sakáloš was supported by the ProDoc program “Geometry, Algebra and Mathematical Physics” and the grant PDFMP2.137071 of the Swiss National Science Foundation.

Pavol Ševera was partially supported by the Swiss National Science Foundation (grants 140985 and 141329).

way to quantize a Lie bialgebra  $\mathfrak{g}$  together with an invariant element  $t \in S^2\mathfrak{g}$  into a quasi-triangular quasi-bialgebra.

Etingof and Kazhdan [4] used Drinfeld's results to quantize an arbitrary Lie bialgebra into a quantum enveloping algebra. Their method is explicit (depending on a choice of a Drinfeld associator).

The natural question of quantization of quasi-Lie bialgebras was addressed by Enriquez and Halbout in [3]. Their methods are quite different — they compare the cohomologies of the prop of quasi-Lie bialgebras with those of the prop of Lie-bialgebras in order to reduce their problem to the one already solved by Etingof and Kazhdan.

We propose a more direct approach to the same problem based on an adjustment of the methods of Etingof and Kazhdan. We describe our construction in detail in Section 2 and compare it with the (slightly reformulated) quantization of Etingof and Kazhdan. The main difference is that we need to replace a certain free module with a projective module and use the fact that projections can be explicitly deformed.

## 2. OUR CONSTRUCTION IN A NUTSHELL

In this section we describe our quantization of Lie quasi-bialgebras almost completely. We omit the discussion of topologies and all the continuity requirements; we leave them, together with basic definitions and all the proofs, to the rest of the paper. This section is, however, sufficient for obtaining explicit formulas (depending on a choice of a Drinfeld associator  $\Phi$ ). We shall also compare it with Etingof-Kazhdan quantization of Lie bialgebras.

Let  $\mathfrak{g}$  be a quasi-Lie bialgebra. Our task is to define explicitly a quasi-bialgebra  $\mathcal{U}_\hbar\mathfrak{g}$  deforming the bialgebra  $\mathcal{U}\mathfrak{g}$ . It is done in two steps:

- (1) We construct a monoidal category  $\mathcal{A}^\Phi$  which is a deformation of the category of  $\mathcal{U}\mathfrak{g}$ -modules ( $\mathcal{A}^\Phi$  is morally the category of  $\mathcal{U}_\hbar\mathfrak{g}$ -modules)
- (2) We construct an object  $C$  of  $\mathcal{A}^\Phi$  (morally,  $C$  is  $\mathcal{U}_\hbar\mathfrak{g}$  as its own module) together with morphisms  $C \rightarrow C \otimes C$  and  $C \rightarrow 1$ , making  $\text{Hom}(C, \cdot)$  to a quasi-monoidal functor. These morphisms make the algebra  $\text{Hom}(C, C)$  to a quasi-bialgebra. We shall find an explicit isomorphism of vector spaces  $\text{Hom}(C, C) \cong \mathcal{U}\mathfrak{g}$  and set

$$\mathcal{U}_\hbar\mathfrak{g} = \text{Hom}(C, C).$$

Let us now describe the two steps in some detail.

**Step 1.** Let  $(\mathfrak{p}, \mathfrak{g})$  be the Manin pair corresponding to the quasi-Lie bialgebra  $\mathfrak{g}$ . We shall encode the category of  $\mathcal{U}\mathfrak{g}$ -modules into the category  $\mathcal{P}$  of  $\mathcal{U}\mathfrak{p}$ -modules as follows. Let

$$A = \text{Hom}_{\mathcal{U}\mathfrak{g}}(\mathcal{U}\mathfrak{p}, \mathbb{K}),$$

where  $\mathbb{K}$  is the base field ( $A$  is roughly the algebra of functions on the homogeneous space  $P/G$ ).  $A$  is a commutative algebra object in the category  $\mathcal{P}$  of  $\mathcal{U}\mathfrak{p}$ -modules. The category of  $\mathcal{U}\mathfrak{g}$ -modules is equivalent to the category  $\mathcal{A}$  of  $A$ -modules in  $\mathcal{P}$  via the co-induction functor

$$\heartsuit : M \mapsto \text{Hom}_{\mathcal{U}\mathfrak{g}}(\mathcal{U}\mathfrak{p}, M).$$

If  $X$  is a  $\mathcal{U}\mathfrak{p}$ -module and  $X \downarrow_{\mathcal{U}\mathfrak{g}}^{\mathcal{U}\mathfrak{p}}$  is  $X$  seen as a  $\mathcal{U}\mathfrak{g}$ -module, then

$$\heartsuit(X \downarrow_{\mathcal{U}\mathfrak{g}}^{\mathcal{U}\mathfrak{p}}) \cong X \otimes A$$

is a free  $A$ -module. For any  $\mathcal{U}\mathfrak{p}$ -modules  $X$  and  $Y$  we have therefore bijections

$$(2.1) \quad \text{Hom}_{\mathcal{U}\mathfrak{g}}(X, Y) \cong \text{Hom}_{\mathcal{A}}(X \otimes A, Y \otimes A) \cong \text{Hom}_{\mathcal{U}\mathfrak{p}}(X, Y \otimes A).$$

The category  $\mathcal{A}_{\text{Free}}$  of *free*  $A$ -modules in  $\mathcal{P}$  is equivalent to the category whose objects are  $\mathcal{U}\mathfrak{p}$ -modules and morphisms are  $\mathcal{U}\mathfrak{g}$ -equivariant maps.

Any Drinfeld associator  $\Phi$  can be used to change the associativity constraint and the braiding in  $\mathcal{P}$ . We shall denote the resulting braided monoidal category by  $\mathcal{P}^\Phi$ . Let us recall that as categories,

$$\mathcal{P}^\Phi = \mathcal{P};$$

only the braided monoidal structure is changed. The algebra  $A$  (with its original product  $A \otimes A \rightarrow A$ ) remains a commutative associative algebra object in  $\mathcal{P}^\Phi$ . Let  $\mathcal{A}^\Phi$  be the category of  $A$ -modules in  $\mathcal{P}^\Phi$ .

Since  $A$  is a commutative algebra in  $\mathcal{P}^\Phi$ , the category  $\mathcal{A}^\Phi$  is monoidal. Let us describe explicitly its subcategory  $\mathcal{A}_{\text{Free}}^\Phi$  of *free*  $A$ -modules, i.e. of  $A$ -modules in  $\mathcal{P}^\Phi$  of the form  $X \otimes A$ , where  $X$  is a  $\mathcal{U}\mathfrak{p}$ -module. As in (2.1) we have bijections

$$(2.2) \quad \text{Hom}_{\mathcal{A}^\Phi}(X \otimes A, Y \otimes A) \cong \text{Hom}_{\mathcal{U}\mathfrak{p}}(X, Y \otimes A) \cong \text{Hom}_{\mathcal{U}\mathfrak{g}}(X, Y).$$

The categories  $\mathcal{A}_{\text{Free}}$  and  $\mathcal{A}_{\text{Free}}^\Phi$  have *the same objects*. Using the identifications (2.1) and (2.2) we can say that they also have *the same morphisms*. The composition of morphisms is, however, different: The composition in  $\mathcal{A}_{\text{Free}}^\Phi$

$$\text{Hom}_{\mathcal{U}\mathfrak{p}}(X, Y \otimes A) \times \text{Hom}_{\mathcal{U}\mathfrak{p}}(Y, Z \otimes A) \rightarrow \text{Hom}_{\mathcal{U}\mathfrak{p}}(X, Z \otimes A)$$

is given by the diagram in  $\mathcal{P}^\Phi$

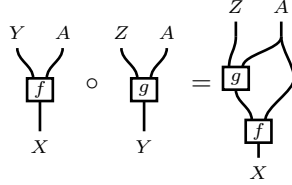

Notice that this composition depends on the Drinfeld associator  $\Phi$ , which appears in the re-bracketing  $(Z \otimes A) \otimes A \rightarrow Z \otimes (A \otimes A)$ . The composition in  $\mathcal{A}_{\text{Free}}$  is given by the same diagram, but seen in  $\mathcal{P}$ .

The tensor product of objects in  $\mathcal{A}_{\text{Free}}^\Phi$  is the same as in  $\mathcal{A}_{\text{Free}}$ :

$$(X \otimes A) \otimes_{\mathcal{A}^\Phi} (Y \otimes A) = (X \otimes Y) \otimes A.$$

The tensor product of morphisms in  $\mathcal{A}_{\text{Free}}^\Phi$

$$\text{Hom}_{\mathcal{U}\mathfrak{p}}(X, Y \otimes A) \times \text{Hom}_{\mathcal{U}\mathfrak{p}}(Z, W \otimes A) \rightarrow \text{Hom}_{\mathcal{U}\mathfrak{p}}(X \otimes Z, (Y \otimes W) \otimes A)$$

is given by the diagram in  $\mathcal{P}^\Phi$

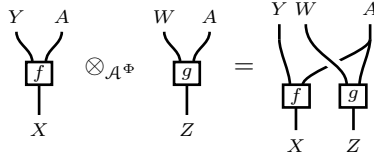

and again depends on  $\Phi$ .

The object  $C \in \mathcal{A}^\Phi$  we define below is, unfortunately, not a free  $A$ -module in  $\mathcal{P}^\Phi$ . It is, however, a projective module, i.e. a direct summand in a free module. Let us describe explicitly the monoidal categories  $\mathcal{A}_{\text{Proj}}$  and  $\mathcal{A}_{\text{Proj}}^\Phi$  of projective  $A$ -modules in  $\mathcal{P}$  and in  $\mathcal{P}^\Phi$ .

The category  $\mathcal{A}_{\text{Proj}}$  is equivalent (via the functor  $\heartsuit$ ) to the category of  $\mathcal{U}\mathfrak{g}$ -modules which are direct summands in  $\mathcal{U}\mathfrak{p}$ -modules, or equivalently, to the category with objects

$$(2.3) \quad (X, p), \quad X \in \mathcal{P}, \quad p \in \text{Hom}_{\mathcal{U}\mathfrak{g}}(X, X) \text{ such that } p \circ p = p$$

and with morphisms

$$f : (X, p) \rightarrow (Y, q), \quad f \in \text{Hom}_{\mathcal{U}\mathfrak{g}}(X, Y) \text{ such that } f = q \circ f \circ p.$$

If  $p : X \rightarrow X$  is as in (2.3) then certainly

$$\heartsuit(p) \circ_{\mathcal{A}} \heartsuit(p) = \heartsuit(p),$$

however, in general,

$$\heartsuit(p) \circ_{\mathcal{A}^\Phi} \heartsuit(p) \neq \heartsuit(p).$$

Fortunately, we can deform  $\heartsuit(p)$  to get a projection in  $\mathcal{A}^\Phi$ : Let  $a = 2p - 1$  (so that  $a \circ a = 1$ ), let  $\tilde{a} = \heartsuit(a)$  *understood as a morphism in  $\mathcal{A}_{\text{Free}}^\Phi$* , and let

$$p^\Phi = (a^\Phi + 1)/2,$$

where

$$a^\Phi = \tilde{a}(\tilde{a}^2)^{-1/2}.$$

Then  $p^\Phi : X \otimes A \rightarrow X \otimes A$  is an idempotent in  $\mathcal{A}_{\text{Free}}^\Phi$  (as  $(a^\Phi)^2 = 1$ ).

Using the correspondence

$$(2.4a) \quad (X, p) \mapsto (X \otimes A, p^\Phi)$$

we identify the objects in  $\mathcal{A}_{\text{Proj}}$  with the objects in  $\mathcal{A}_{\text{Proj}}^\Phi$ .<sup>1</sup> We also identify morphisms via

$$(2.4b) \quad (f : X \rightarrow Y, f = q \circ f \circ p) \mapsto (f^\Phi := q^\Phi \circ \heartsuit(f) \circ p^\Phi : X \otimes A \rightarrow Y \otimes A).$$

This makes the category  $\mathcal{A}_{\text{Proj}}^\Phi$  (together with its monoidal structure) fully explicit.

**Step 2.** Suppose that  $C$  is an object in a linear monoidal category, for example in  $\mathcal{A}^\Phi$ , and that we have a strong quasi-monoidal structure on the functor

$$(2.5) \quad \text{Hom}(C, \cdot).$$

This means that we have morphisms  $\epsilon : C \rightarrow 1$  and  $\blacktriangle : C \rightarrow C \otimes C$ , satisfying the following conditions: For any objects  $S, T$ , the composition

$$\delta_{S,T} : \text{Hom}(C, S) \otimes \text{Hom}(C, T) \xrightarrow{\otimes} \text{Hom}(C \otimes C, S \otimes T) \xrightarrow{\circ \blacktriangle} \text{Hom}(C, S \otimes T)$$

is a bijection,

$$(2.6) \quad (\text{id} \otimes \epsilon) \circ \blacktriangle = (\epsilon \otimes \text{id}) \circ \blacktriangle = \text{id},$$

and

$$\text{Hom}(C, 1) = \mathbb{k}\epsilon.$$

<sup>1</sup>More precisely, we should define  $\mathcal{A}_{\text{Proj}}^\Phi$  as the category, where objects are pairs  $(X, \pi)$ , where  $X$  is a  $\mathcal{U}\mathfrak{p}$ -module and  $\pi : X \otimes A \rightarrow X \otimes A$  a projection in  $\mathcal{A}^\Phi$ ; the image of  $\pi$  is our projective  $A$ -module in  $\mathcal{P}^\Phi$ .

In this case, the algebra

$$H = \text{Hom}(C, C)$$

has a unique quasi-bialgebra structure, such that the functor (2.5), understood as a functor to the category of  $H$ -modules, is strongly monoidal, with the monoidal structure given by the morphisms  $\delta_{S,T}$ . In particular, if  $B$  is a quasi-bialgebra, we take the (monoidal) category of  $B$ -modules, and set  $C = B$ ,  $\blacktriangle = \Delta_B$  and  $\epsilon = \epsilon_B$ , then  $H = B$ .

Explicitly, the coproduct

$$\Delta : H \rightarrow H \otimes H$$

is given by the composition

$$H = \text{Hom}(C, C) \xrightarrow{\circ \blacktriangle} \text{Hom}(C, C \otimes C) \xrightarrow{\delta_{C,C}^{-1}} \text{Hom}(C, C) \otimes \text{Hom}(C, C) = H \otimes H.$$

The associator  $\Phi_H \in H \otimes H \otimes H$  is the image of  $1 \otimes 1 \otimes 1$  under

$$\begin{aligned} H \otimes H \otimes H &\xrightarrow{\delta_{C,C} \otimes \text{id}} \\ &\text{Hom}(C, C \otimes C) \otimes H \xrightarrow{\delta_{C \otimes C, C}} \text{Hom}(C, (C \otimes C) \otimes C) \xrightarrow{\gamma_{C,C,C}} \\ &\text{Hom}(C, C \otimes (C \otimes C)) \xrightarrow{\delta_{C,C \otimes C}^{-1}} H \otimes \text{Hom}(C, C \otimes C) \\ &\xrightarrow{\text{id} \otimes \delta_{C,C}^{-1}} H \otimes H \otimes H, \end{aligned}$$

where  $\gamma_{C,C,C} : (C \otimes C) \otimes C \rightarrow C \otimes (C \otimes C)$  is the associativity constraint. Finally, the counit

$$\epsilon : H \rightarrow \mathbb{K}$$

is given by

$$f \circ \epsilon = \epsilon(f)\epsilon.$$

Our task is to construct  $(C, \blacktriangle, \epsilon)$  in the monoidal category  $\mathcal{A}^\Phi$ , together with an isomorphism

$$(2.7) \quad \text{Hom}(C, C) \cong \mathcal{U}\mathfrak{g}$$

of vector spaces. Notice that if we use the category  $\mathcal{A}$  instead, which is equivalent to the category of  $\mathcal{U}\mathfrak{g}$ -modules via the functor  $\heartsuit$ , then

$$C = \heartsuit(\mathcal{U}\mathfrak{g}), \quad \blacktriangle = \heartsuit(\Delta_{\mathcal{U}\mathfrak{g}}), \quad \epsilon = \heartsuit(\epsilon_{\mathcal{U}\mathfrak{g}})$$

gives  $H = \mathcal{U}\mathfrak{g}$  as a bialgebra. We need to find a suitable replacement for  $\heartsuit(\mathcal{U}\mathfrak{g})$  in  $\mathcal{A}^\Phi$ . A natural approach is to make  $\mathcal{U}\mathfrak{g}$  to a  $\mathcal{U}\mathfrak{p}$ -module, or at least to a direct summand of a  $\mathcal{U}\mathfrak{p}$ -module, since then  $C = \heartsuit(\mathcal{U}\mathfrak{g})$  can be seen as an object of  $\mathcal{A}_{\text{Free}}^\Phi$  or of  $\mathcal{A}_{\text{Proj}}^\Phi$  and (2.7) holds.

Let us first construct  $(C, \blacktriangle, \epsilon)$  in the case when  $\mathfrak{g}$  is a Lie bialgebra. In that case  $H = \mathcal{U}_\hbar \mathfrak{g}$  will be the bialgebra constructed by Etingof and Kazhdan. The bijection

$$\mathcal{U}\mathfrak{g} \cong \mathcal{U}\mathfrak{p}/(\mathcal{U}\mathfrak{p})\mathfrak{g}^*$$

(given by the inclusion  $\mathcal{U}\mathfrak{g} \subset \mathcal{U}\mathfrak{p}$ ) makes  $\mathcal{U}\mathfrak{g}$  to a  $\mathcal{U}\mathfrak{p}$ -module, and we define  $C$  to be the free  $A$ -algebra in  $\mathcal{P}^\Phi$

$$C = \mathcal{U}\mathfrak{g} \otimes A = \heartsuit(\mathcal{U}\mathfrak{g}).$$

We also set

$$\blacktriangle = \heartsuit(\Delta_{\mathcal{U}\mathfrak{g}}), \quad \epsilon = \heartsuit(\epsilon_{\mathcal{U}\mathfrak{g}}),$$

where  $\Delta_{\mathcal{U}\mathfrak{g}}$  and  $\varepsilon_{\mathcal{U}\mathfrak{g}}$  are the coproduct and the counit of the (cocommutative) bialgebra  $\mathcal{U}\mathfrak{g}$ .

By (2.2) we have a bijection

$$H = \text{Hom}_{\mathcal{A}^\Phi}(C, C) \cong \text{Hom}_{\mathcal{U}\mathfrak{g}}(\mathcal{U}\mathfrak{g}, \mathcal{U}\mathfrak{g}) = \mathcal{U}\mathfrak{g}$$

so we indeed defined a new quasi-bialgebra (actually bialgebra, due to co-associativity of  $\blacktriangle$ ) structure on  $\mathcal{U}\mathfrak{g}$ . This is a slight reformulation of the quantization of Etingof and Kazhdan.

Let us now suppose again that  $\mathfrak{g}$  is a quasi-Lie bialgebra. The basic problem is that in this case we can't extend the  $\mathcal{U}\mathfrak{g}$ -action (by multiplication) on  $\mathcal{U}\mathfrak{g}$  to a  $\mathcal{U}\mathfrak{p}$ -action, hence we can't take for  $C$  a free  $A$ -module. We shall, however, be able to find a  $C$  which is a *projective*  $A$ -module. Namely, let

$$Q = \heartsuit(\mathcal{U}\mathfrak{g}) = \text{Hom}_{\mathcal{U}\mathfrak{g}}(\mathcal{U}\mathfrak{p}, \mathcal{U}\mathfrak{g}),$$

understood as a  $\mathcal{U}\mathfrak{p}$ -module. We have a surjection  $\pi : Q = \text{Hom}_{\mathcal{U}\mathfrak{g}}(\mathcal{U}\mathfrak{p}, \mathcal{U}\mathfrak{g}) \rightarrow \mathcal{U}\mathfrak{g}$  given by  $f \mapsto f(1)$ . If we choose a  $f_0 \in Q$  such that  $f_0(1) = 1$ , then

$$\iota : \mathcal{U}\mathfrak{g} \rightarrow Q, \quad z \mapsto z \cdot f_0$$

is a (one-side) inverse of  $\pi$ . In this way we can see  $\mathcal{U}\mathfrak{g}$  as a direct summand in the  $\mathcal{U}\mathfrak{p}$ -module  $Q$ , i.e. we can replace it by the pair

$$(Q, p = \iota \circ \pi).$$

A convenient  $f_0$  can be constructed as follows. As a vector space,

$$\mathfrak{p} = \mathfrak{g} \oplus \mathfrak{g}^*,$$

which gives an isomorphism of vector spaces

$$\mathcal{U}\mathfrak{g} \otimes S\mathfrak{g}^* \rightarrow \mathcal{U}\mathfrak{p},$$

namely  $z \otimes x \mapsto z\sigma(x)$ , where  $\sigma : S\mathfrak{g}^* \rightarrow \mathcal{U}\mathfrak{p}$  is the symmetrization map. The projection  $f_0 : \mathcal{U}\mathfrak{p} \cong \mathcal{U}\mathfrak{g} \otimes S\mathfrak{g}^* \rightarrow \mathcal{U}\mathfrak{g}$  is defined by sending  $S^{>0}\mathfrak{g}^*$  to 0.

We thus set (see (2.4))

$$C = (Q \otimes A, p^\Phi), \quad \blacktriangle = p^\Phi \otimes p^\Phi \circ \Delta_{\mathcal{U}\mathfrak{g}} \circ p^\Phi, \quad \epsilon = \varepsilon_{\mathcal{U}\mathfrak{g}}^\Phi.$$

Unfortunately, Equation (2.6) is not satisfied, which means that  $\text{Hom}_{\mathcal{A}^\Phi}(C, C)$  is a quasi-bialgebra with a weak counit. This defect can be easily repaired by a twist. Namely, let

$$\blacktriangle' = (r^{-1} \otimes s^{-1}) \circ \blacktriangle$$

where

$$r = (\epsilon \otimes 1) \circ \blacktriangle, \quad s = (1 \otimes \epsilon) \circ \blacktriangle.$$

Then the triple

$$(C, \blacktriangle', \epsilon)$$

satisfies all the requirements and we set

$$(2.8) \quad \mathcal{U}_{\hbar}\mathfrak{g} = \text{Hom}_{\mathcal{A}^\Phi}(C, C).$$

**Remarks.**

- (1) If  $\mathfrak{g}$  is finite-dimensional then we can replace the coinduction  $\heartsuit$  with the induction

$$M \mapsto \mathcal{U}\mathfrak{p} \otimes_{\mathcal{U}\mathfrak{g}} M,$$

the algebra  $A$  with the coalgebra

$$\mathcal{U}\mathfrak{p} \otimes_{\mathcal{U}\mathfrak{g}} \mathbb{K} = \mathcal{U}\mathfrak{p}/(\mathcal{U}\mathfrak{p})\mathfrak{g}$$

and the  $\mathcal{U}\mathfrak{p}$ -module  $Q$  with  $\mathcal{U}\mathfrak{p}$ . In this case we don't need to use any topologies.

- (2) While it is clear that  $\mathcal{U}_{\hbar}\mathfrak{g}$  is a deformation of  $\mathcal{U}\mathfrak{g}$ , we should verify that its first order part is given by the quasi-Lie bialgebra structure on  $\mathfrak{g}$ . To do it we repeat the idea of Etingof and Kazhdan. The functor

$$F : \mathcal{P}^{\Phi} \rightarrow \mathcal{V}$$

(where  $\mathcal{V}$  is the category of vector spaces), given by

$$F(X) = \text{Hom}_{\mathcal{A}^{\Phi}}(C, X \otimes A),$$

is naturally isomorphic to the forgetful functor. Both  $F$  and the forgetful functor are quasi-monoidal, but with different quasi-monoidal structures. In this way we get two quasi-triangular quasi-bialgebra structures on the representing object  $\mathcal{U}\mathfrak{p}$ , differing by a twist. One of them is the standard quasi-bialgebra structure coming from  $\Phi$ , while the other is such that  $\mathcal{U}\mathfrak{p}$  contains  $\mathcal{U}_{\hbar}\mathfrak{g}$  as a sub-quasi-bialgebra. We compute the classical part of the twist and show that we get the classical twist of  $\mathfrak{p}$  which makes  $\mathfrak{g}$  to a sub-quasi-Lie bialgebra.

## 3. NOTATION

Some general notations:

- $\triangleright, \triangleleft$  denote left and right actions. E.g. if  $\mathfrak{g}$  is a Lie algebra and  $M$  its left module,  $x \in \mathfrak{g}$ ,  $m \in M$  then  $x \triangleright m$  denotes  $x$  applied to  $m$ .
- $\subset_{\text{os}}$  and  $\subset_{\text{bs}}$  mean “is an open vector subspace of” and “is a bounded vector subspace of” (Definition A.14).
- $\hat{\otimes}$  is the completed tensor product (Appendix A.2). It turns  $\mathcal{V}^{\text{cpl}}$  into a symmetric monoidal category.
- $\text{Hom}_{\mathcal{U}\mathfrak{g}}^C$ ,  $\text{Hom}_{\mathbb{K}}^C$  denote spaces of continuous  $\mathcal{U}\mathfrak{g}$ -linear or  $\mathbb{K}$ -linear maps equipped with the strong topology.

The quasi-Lie bialgebras and some elements that we use:

- $(\mathfrak{g}, \delta, \varphi)$  the quasi-Lie bialgebra over  $\mathbb{K}$  we want to quantize.
- $e_i$  a basis of  $\mathfrak{g}$  and  $e^i$  the dual basis
- $(\mathfrak{p}, \delta_{\mathfrak{p}}, \varphi_{\mathfrak{p}})$  the “double” quasi-Lie bialgebra of  $\mathfrak{g}$  defined in Section 4.6.
- $t$  the invariant element of  $S^2\mathfrak{p}$ . Section 4.6.

The categories:

- $\mathcal{C}$  a general category. Hom-sets are denoted by  $\text{Hom}_{\mathcal{C}}(X, Y)$  or by  $\mathcal{C}(X, Y)$ .
- $\text{Split}(\mathcal{C})$  is the Karoubi envelope of a category  $\mathcal{C}$ . Section 7.1.
- $\mathcal{V}, \mathcal{V}^{\text{top}}, \mathcal{V}^{\text{cpl}}, \mathcal{V}^{\text{haus}}$  — vector spaces, topological vector spaces, complete topological vector spaces and Hausdorff topological vector spaces. Appendix A.

- $\mathcal{V}_{\mathbb{K}[[\hbar]]}^{\hbar\text{-cpl}}$  and  $\mathcal{V}_{\mathbb{K}[[\hbar]]}^{\text{cpl}}$  — category of topological  $\mathbb{K}[[\hbar]]$ -modules that are  $\hbar$ -complete and the category of complete  $\mathbb{K}[[\hbar]]$ -modules. Appendix E.
- $\mathcal{G}, \mathcal{P}$  — equicontinuous left  $\mathfrak{g}$ -modules and equicontinuous left  $\mathfrak{p}$ -modules (Section 8.1).
- $\mathcal{A}, \mathcal{F}$  — right  $A$ -modules and free right  $A$ -modules in  $\mathcal{P}$  (Section 8.6). There is an obvious fully-faithful functor  $\mathcal{F} \rightarrow \mathcal{A}$ .
- $\mathcal{P}_{\hbar}$  — category with the same objects as  $\mathcal{P}$  but with hom-sets  $\mathcal{P}_{\hbar}(M, N) := \mathcal{P}(M, N)[[\hbar]]$ . See Section 10.
- $\mathcal{F}_{\hbar}$  — the same construction applied to  $\mathcal{F}$ . Equivalently, the category of free right  $A$ -modules in  $\mathcal{P}_{\hbar}$ .
- $\mathcal{P}_{\hbar}^{\Phi}$  — the same category as  $\mathcal{P}_{\hbar}$  but with the braiding and associativity isomorphism “quantized” using a Drinfeld associator  $\Phi$  as described in Section 11.1.
- $\mathcal{F}_{\hbar}^{\Phi}$  — right free  $A$ -modules in  $\mathcal{P}_{\hbar}^{\Phi}$  (Section 11.2).

The functors:

- $\xrightarrow{\text{forg}}$  denotes forgetful functors. Possibly non-obvious  $\mathcal{P}_{\hbar} \xrightarrow{\text{forg}} \mathcal{V}_{\mathbb{K}[[\hbar]]}^{\text{cpl}}$  is defined in Section 10.
- $\heartsuit : \mathcal{G} \rightarrow \mathcal{P} : M \mapsto \heartsuit M := \text{Hom}_{\mathcal{U}\mathfrak{g}}^C(\mathcal{U}\mathfrak{d}, M)$ . See Section 8.2.
- By  $\tilde{\heartsuit} : \mathcal{G} \rightarrow \mathcal{A}$  we denote  $\heartsuit$  when we want to stress that it goes to  $\mathcal{A}$ . Section 8.7.
- $\mathbf{h}_{\text{something}}$  is the functor represented by something (Section 7).
- $\mathbf{h} : \mathcal{F} \rightarrow \mathcal{V}^{\text{cpl}}$  the functor represented by  $(Q \hat{\otimes} A, p) \in \text{Split}(\mathcal{F})$  (Section 9.5). We denote by the same letter also the functor  $\mathbf{h} : \mathcal{F}_{\hbar} \rightarrow \mathcal{V}_{\mathbb{K}[[\hbar]]}^{\text{cpl}}$  represented by  $(Q \hat{\otimes} A, p) \in \text{Split}(\mathcal{F}_{\hbar})$ .
- $\mathbf{h}^{\Phi} : \mathcal{F}_{\hbar}^{\Phi} \rightarrow \mathcal{V}_{\mathbb{K}[[\hbar]]}^{\text{cpl}}$  the functor represented by  $(Q \hat{\otimes} A, p^{\Phi}) \in \text{Split}(\mathcal{F}_{\hbar}^{\Phi})$ . Section 11.6.

Important objects

- $A = \heartsuit \mathbb{K}$  is a commutative algebra in  $\mathcal{P}$  (Section 8.3).
- $C \in \text{ob}(\mathcal{G})$  is  $\mathcal{U}\mathfrak{g}$  as its own module by left multiplication.
- $Q = \heartsuit C \in \text{ob}(\mathcal{P})$ . It is useful, because the coalgebra  $\tilde{\heartsuit} C$  in  $\mathcal{A}$  representing  $\mathbf{h}$  is a direct summand of  $Q \otimes A$ . Section 9.

Important maps:

- $\pi_M : \heartsuit(M) \rightarrow M$  a natural epimorphism in  $\mathcal{G}$  defined for  $M \in \mathcal{G}$  by

$$\pi_M : \text{Hom}_{\mathcal{U}\mathfrak{g}}^C(\mathcal{U}\mathfrak{d}, M) \rightarrow M : s \mapsto s(1) .$$

In particular we have an epimorphism  $\pi_C : Q \rightarrow C$  in  $\mathcal{G}$ .

- We also denote  $\varepsilon_A := \pi_{\mathbb{K}} : A \rightarrow \mathbb{K}$ . It is an augmentation on  $A$  if we consider  $A$  as an algebra in  $\mathcal{G}$ . It is however not a morphism in  $\mathcal{P}$ . Section 8.5. On pictures, we denote  $\varepsilon_A$  by  $\bullet$ .

$A$

- $\iota_C \in \mathcal{G}(C, Q)$  and  $s_0 \in Q$ . Since  $C$  is a free one-dimensional  $\mathcal{U}\mathfrak{g}$ -module one can choose a right inverse  $\iota_C : C \rightarrow Q$  of  $\pi_C : Q \rightarrow C$  just by specifying an element  $s_0 = \iota_C(1) \in Q$ . Our choice of  $s_0$  is described in Section 9.3. On our pictures, we denote the element  $s_0 \in Q$  (regarded as a linear map

$$\mathbb{K} \rightarrow Q) \text{ as } \begin{array}{c} Q \\ \circlearrowleft \\ \bullet \end{array} .$$

- Projection<sup>2</sup>  $p \in \mathcal{A}(Q \hat{\otimes} A, Q \hat{\otimes} A)$ . The composition  $\iota_C \circ \pi_C : Q \rightarrow Q$  is a projection in  $\mathcal{G}$  with image  $C$ . Applying  $\tilde{\vee}$  and composing with isomorphism  $Q \hat{\otimes} A \cong \tilde{\vee} Q$  (which we get from Theorem 8.5 part (2)) we get a projection in  $\mathcal{A}$

$$p : Q \hat{\otimes} A \xrightarrow{\cong} \tilde{\vee} Q \xrightarrow{\tilde{\vee}(\iota_C \circ \pi_C)} \tilde{\vee} Q \xrightarrow{\cong} Q \hat{\otimes} A.$$

This enables us to see  $\tilde{\vee} C$  as an object  $(Q \hat{\otimes} A, p)$  in  $\text{Split}(\mathcal{F})$ . Details in Section 9.

- $\Delta \in \mathcal{G}(C, C \hat{\otimes} C)$ ,  $\varepsilon \in \mathcal{G}(C, \mathbb{K})$  is the coalgebra structure on  $C \in \text{ob}(\mathcal{G})$  coming from the bialgebra structure on  $\mathcal{U}\mathfrak{g}$ .
- $\Delta_Q \in \mathcal{F}(Q \hat{\otimes} A, Q \hat{\otimes} Q \hat{\otimes} A)$ ,  $\varepsilon_Q \in \mathcal{F}(Q \hat{\otimes} A, A)$  is a coalgebra structure on  $(Q \hat{\otimes} A, p)$  in  $\text{Split}(\mathcal{F})$ . We get it as follows:  $C$  is a coalgebra in  $\mathcal{G}$ , so  $\tilde{\vee} C$  is a coalgebra in  $\mathcal{A}$ . We see  $\tilde{\vee} C \in \mathcal{A}$  as  $(Q \hat{\otimes} A, p) \in \text{Split}(\mathcal{F})$  and thus get a coalgebra structure on  $(Q \hat{\otimes} A, p)$ . Section 9.
- Projection  $p^\Phi \in \mathcal{F}_\hbar^\Phi(Q \hat{\otimes} A, Q \hat{\otimes} A)$ . One can regard  $p \in \mathcal{F}_\hbar(Q \hat{\otimes} A, Q \hat{\otimes} A)$  as a morphism in  $\mathcal{F}_\hbar^\Phi(Q \hat{\otimes} A, Q \hat{\otimes} A)$  although there it does not necessarily satisfy  $p \circ p = p$ . To force this condition, we use Lemma 11.4 and get a projection  $p^\Phi \in \mathcal{F}_\hbar^\Phi(Q \hat{\otimes} A, Q \hat{\otimes} A)$ . Section 11.4.
- $\Delta'_Q \in \mathcal{F}_\hbar^\Phi(Q \hat{\otimes} A, (Q \hat{\otimes} A) \otimes_A (Q \hat{\otimes} A))$ ,  $\varepsilon'_Q \in \mathcal{F}_\hbar^\Phi(Q \hat{\otimes} A, Q \hat{\otimes} A)$  are an attempt to get a quasi-coalgebra structure on  $(Q \hat{\otimes} A, \mathfrak{p}^\Phi)$  in  $\text{Split}(\mathcal{F}_\hbar^\Phi)$ . See the formulas (11.3).
- $r, s \in \mathcal{F}_\hbar^\Phi(Q \hat{\otimes} A, Q \hat{\otimes} A)$  defined by the formulas (11.5) measure the failure of  $\varepsilon'_Q$  to be a counit for  $\Delta'_Q$  as in Lemma 11.11.
- $\Delta_Q^\Phi \in \mathcal{F}_\hbar^\Phi(Q \hat{\otimes} A, (Q \hat{\otimes} A) \otimes_A (Q \hat{\otimes} A))$ ,  $\varepsilon_Q^\Phi \in \mathcal{F}_\hbar^\Phi(Q \hat{\otimes} A, Q \hat{\otimes} A)$  defined by (11.6) give a quasi-coalgebra structure on  $(Q \hat{\otimes} A, \mathfrak{p}^\Phi) \in \text{Split}(\mathcal{F}_\hbar^\Phi)$ . (See also Lemma 11.11.)
- $m \mapsto \hat{m} : M \rightarrow \mathbf{h}(M \hat{\otimes} A)$  is a natural isomorphism between  $\mathcal{P} \xrightarrow{\text{forg}} \mathcal{V}^{\text{cpl}}$  and  $\mathcal{P} \xrightarrow{\hat{\otimes} A} \mathcal{F} \xrightarrow{\mathbf{h}} \mathcal{V}^{\text{cpl}}$ . It is a composition of isomorphisms

$$M \xrightarrow{\cong} \mathcal{G}(C, M) \xrightarrow{\tilde{\vee}} \mathcal{A}(\tilde{\vee} C, \tilde{\vee} M) \xrightarrow{\cong} \text{Split}(\mathcal{F})\left((Q \hat{\otimes} A, p), M \hat{\otimes} A\right)$$

where the first map assigns to  $m \in M$  a  $\mathcal{G}$ -morphism  $C \rightarrow M : 1 \mapsto m$  and the last map uses the isomorphisms  $\tilde{\vee} C \cong (Q \hat{\otimes} A, p)$  and  $\tilde{\vee} M \cong M \hat{\otimes} A$ . See Notation 9.5.

One can also regard  $m \mapsto \hat{m}$  as an isomorphism between  $\mathcal{P}_\hbar \xrightarrow{\text{forg}} \mathcal{V}_{\mathbb{K}[[\hbar]]}^{\text{cpl}}$

and  $\mathcal{P}_\hbar \xrightarrow{\hat{\otimes} A} \mathcal{F}_\hbar \xrightarrow{\mathbf{h}} \mathcal{V}_{\mathbb{K}[[\hbar]]}^{\text{cpl}}$ .

- $\alpha : m \mapsto \hat{m}^\Phi = \hat{m} \circ_{\mathcal{F}_\hbar^\Phi} p^\Phi : M \rightarrow \mathbf{h}^\Phi(M \hat{\otimes} A)$  is a natural isomorphism between  $\mathcal{P}_\hbar^\Phi \xrightarrow{\text{forg}} \mathcal{V}_{\mathbb{K}[[\hbar]]}^{\text{cpl}}$  and  $\mathcal{P}_\hbar^\Phi \xrightarrow{\hat{\otimes} A} \mathcal{F}_\hbar^\Phi \xrightarrow{\mathbf{h}} \mathcal{V}_{\mathbb{K}[[\hbar]]}^{\text{cpl}}$ . Section 11.6.

#### 4. QUASI-BIALGEBRAS

For the convenience of the reader we gather here some results of Drinfeld from [1].

<sup>2</sup>By “projection” we want to say here that  $p \circ p = p$ .

**Definition 4.1.** A quasi-bialgebra is an associative algebra  $H$  together with algebra morphisms  $\Delta : H \rightarrow H \otimes H$ ;  $\varepsilon : H \rightarrow \mathbb{K}$  and an invertible element  $\Phi \in H \otimes H \otimes H$  satisfying

$$(4.1) \quad (\text{id} \otimes \Delta) \circ \Delta(a) = \Phi \cdot [(\Delta \otimes \text{id}) \circ \Delta(a)] \cdot \Phi^{-1}$$

$$(4.2) \quad (\text{id} \otimes \text{id} \otimes \Delta)(\Phi) \cdot (\Delta \otimes \text{id} \otimes \text{id})(\Phi) = (1 \otimes \Phi) \cdot (\text{id} \otimes \Delta \otimes \text{id})(\Phi) \cdot (\Phi \otimes 1)$$

$$(4.3) \quad (\varepsilon \otimes \text{id}) \circ \Delta = \text{id} ; \quad (\text{id} \otimes \varepsilon) \circ \Delta = \text{id}$$

$$(4.4) \quad (\text{id} \otimes \varepsilon \otimes \text{id})\Phi = 1 \otimes 1$$

**4.1. Quasi-triangular structure.**  $R$ -matrix is an invertible element  $R \in H \otimes H$  satisfying<sup>3</sup>

$$(4.5) \quad \Delta^{op}(a) = R \cdot \Delta(a) \cdot R^{-1}, \quad \forall a \in A$$

$$(4.6) \quad (\Delta \otimes \text{id})(R) = \Phi^{312} \cdot R^{13} \cdot (\Phi^{132})^{-1} \cdot R^{23} \cdot \Phi$$

$$(4.7) \quad (\text{id} \otimes \Delta)(R) = (\Phi^{231})^{-1} \cdot R^{13} \cdot \Phi^{213} \cdot R^{12} \cdot \Phi^{-1}$$

**4.2. Twisting.** Given an invertible elements  $F \in H \otimes H$  satisfying

$$(\text{id} \otimes \varepsilon)F = 1 = (\varepsilon \otimes \text{id})F$$

we get a new quasi-bialgebra structure on the algebra  $H$  by keeping the same  $\varepsilon$  and replacing  $\Delta$ ,  $\Phi$  and  $R$  (if the original was quasi-triangular) by

$$(4.8) \quad \tilde{\Delta}(a) = F \cdot \Delta(a) \cdot F^{-1}, \quad \forall a \in A$$

$$(4.9) \quad \tilde{\Phi} = F^{23} \cdot (\text{id} \otimes \Delta)(F) \cdot \Phi \cdot (\Delta \otimes \text{id})(F^{-1}) \cdot (F^{12})^{-1}$$

$$(4.10) \quad \tilde{R} = F^{21} \cdot R \cdot F$$

Next we recall what are the corresponding classical notions.

**4.3. Quasi-Lie bialgebras.** A quasi-Lie bialgebra is a triple  $(\mathfrak{g}, \delta, \varphi)$  where

- $\mathfrak{g}$  is a Lie-algebra;
- $\delta$  is a 1-cocycle  $\delta : \mathfrak{g} \rightarrow \wedge^2 \mathfrak{g}$ ;
- $\varphi \in \wedge^3 \mathfrak{g}$

satisfying the following equations<sup>4</sup>

$$(4.11) \quad \frac{1}{2} \text{Alt}(\delta \otimes \text{id})\delta(x) = [x \otimes 1 \otimes 1 + 1 \otimes x \otimes 1 + 1 \otimes 1 \otimes x, \varphi] \quad \forall x \in \mathfrak{g} ;$$

$$(4.12) \quad \text{Alt}(\delta \otimes \text{id} \otimes \text{id})(\varphi) = 0 .$$

**4.4. Twisting of quasi-Lie bialgebras.** Let  $(\mathfrak{g}, \delta, \varphi)$  be a quasi-Lie bialgebra and  $f \in \wedge^2 \mathfrak{g}$ . We get a new quasi-Lie bialgebra structure  $(\mathfrak{g}, \tilde{\delta}, \tilde{\varphi})$  on the same Lie algebra  $\mathfrak{g}$  by taking

$$(4.13) \quad \tilde{\delta}(x) := \delta(x) + [x \otimes 1 + 1 \otimes x, f] ;$$

$$(4.14) \quad \tilde{\varphi} = \varphi + \frac{1}{2} \text{Alt}(\delta \otimes \text{id})f - \text{CYB}(f)$$

where

$$\text{CYB}(f) := [f^{12}, f^{13}] + [f^{12}, f^{23}] + [f^{13}, f^{23}]$$

is the left hand side of the classical Yang-Baxter equation.

<sup>3</sup> $(a \otimes b \otimes c)^{312} = b \otimes c \otimes a$

<sup>4</sup> $\text{Alt} : \mathfrak{g}^{\otimes n} \rightarrow \mathfrak{g}^{\otimes n} : x_1 \otimes \dots \otimes x_n \mapsto \sum_{\sigma \in S_n} \text{sgn}(\sigma) \cdot x_{\sigma(1)} \otimes \dots \otimes x_{\sigma(n)}$ , so we don't divide by  $n!$ .

**4.5. Quasi-Hopf QUE algebras.** Quasi-Hopf QUE<sup>5</sup> algebra is a topological quasi-bialgebra  $(A, \Delta, \varepsilon, \Phi)$  over  $\mathbb{K}[[\hbar]]$  s.t.

- (1)  $\Phi \equiv 1 \pmod{\hbar}$ ;
- (2)  $A/\hbar A$  is a universal enveloping algebra;
- (3)  $A$  is a topologically free  $\mathbb{K}[[\hbar]]$ -module;
- (4)  $\text{Alt } \Phi \equiv 0 \pmod{\hbar^2}$ .

We twist as in the section (4.2) by elements  $F$  that satisfy also  $F \equiv 1 \pmod{\hbar}$ . One can see that  $\text{Alt } \Phi \equiv 0 \pmod{\hbar^2}$  is preserved under twisting.

**Theorem 4.2.** *Let  $(A, \Delta, \varepsilon, \Phi)$  be a quasi-Hopf QUE algebra and  $A/\hbar A = \mathcal{U}\mathfrak{g}$ .*

- (1) *By twisting one can achieve  $\Phi \equiv 1 \pmod{\hbar^2}$ .*
- (2) *If we assume  $\Phi \equiv 1 \pmod{\hbar^2}$  then we get on  $\mathfrak{g}$  a structure of a quasi-Lie bialgebra by taking*
  - $\varphi := \frac{1}{\hbar^2} \cdot \text{Alt}(\Phi) \pmod{\hbar}$ ,
  - $\delta(x) := \frac{1}{\hbar} (\Delta(x) - \Delta^{op}(x))$ .
- (3) *If we twist  $(A, \Delta, \varepsilon, \Phi)$  by  $F$  into  $(A, \tilde{\Delta}, \tilde{\varepsilon}, \tilde{\Phi})$  while keeping  $\Phi \equiv \tilde{\Phi} \equiv 1 \pmod{\hbar^2}$  then the quasi-Lie bialgebra  $(\mathfrak{g}, \tilde{\delta}, \tilde{\varphi})$  corresponding to  $(A, \tilde{\Delta}, \tilde{\varepsilon}, \tilde{\Phi})$  can be obtained from  $(\mathfrak{g}, \delta, \varphi)$  by twisting via*

$$f = -\frac{1}{\hbar} \cdot \text{Alt}(F) \pmod{\hbar} .$$

**Theorem 4.3.** *Let  $(A, \Delta, \varepsilon, \Phi, R)$  be a quasi-triangular quasi-Hopf QUE algebra,  $A/\hbar A = \mathcal{U}\mathfrak{g}$ . Denote*

$$t := \frac{1}{\hbar} \cdot (R^{21} \cdot R - 1) \pmod{\hbar} \in \mathcal{U}\mathfrak{g} \otimes \mathcal{U}\mathfrak{g} .$$

*Then*

- (1)  *$t$  is a symmetric  $\mathfrak{g}$ -invariant element of  $\mathfrak{g} \otimes \mathfrak{g}$  and does not change under twists.*
- (2) *By twisting of  $(A, \Delta, \varepsilon, \Phi, R)$  one can achieve that we have both*
  - $\frac{R-1}{\hbar} \equiv \frac{t}{2} \pmod{\hbar}$ ;
  - $\Phi \equiv 1 \pmod{\hbar^2}$ .

*In that case one has*

- (a)  $\frac{1}{\hbar^2} \text{Alt}(\Phi) \equiv \frac{1}{4} [t^{12}, t^{23}] \pmod{\hbar}$ ;
- (b)  $\Delta \equiv \Delta^{op} \pmod{\hbar^2}$ .

**Definition 4.4.** Let  $\mathfrak{g}$  be a Lie algebra and  $t \in \mathfrak{g} \otimes \mathfrak{g}$  a symmetric  $\mathfrak{g}$ -invariant element. We can define on  $\mathfrak{g}$  a quasi-Lie bialgebra structure by taking

$$\delta := 0 ; \quad \varphi := \frac{1}{4} [t^{12}, t^{23}] = -\frac{1}{4} CYB(t, t) .$$

We call it the quasi-Lie bialgebra associated to the pair  $(\mathfrak{g}, t)$ .

---

<sup>5</sup>QUE = quantum universal enveloping

**4.6. Double quasi-Lie bialgebra.** For a quasi-Lie bialgebra  $(\mathfrak{g}, \delta, \varphi)$  we form a topological<sup>6</sup> vector space  $\mathfrak{p} := \mathfrak{g} \oplus \mathfrak{g}^*$  and take the unique Lie bracket  $[\cdot, \cdot]_{\mathfrak{p}}$  satisfying the following properties:

- (1)  $[\cdot, \cdot]_{\mathfrak{p}}$  restricted to  $\mathfrak{g} \otimes \mathfrak{g}$  is  $[\cdot, \cdot]_{\mathfrak{g}}$ .
- (2) If we regard  $\delta$  and  $\varphi$  as maps (see the claim D.6)

$$\delta : \mathfrak{g}^* \hat{\otimes} \mathfrak{g}^* \rightarrow \mathfrak{g}^*; \quad \varphi : \mathfrak{g}^* \hat{\otimes} \mathfrak{g}^* \rightarrow \mathfrak{g}$$

then  $[\cdot, \cdot]_{\mathfrak{p}}$  restricted to  $\mathfrak{g}^* \otimes \mathfrak{g}^*$  is equal to  $\delta + \varphi$ .

- (3) The canonical scalar product on  $\mathfrak{p}$  given by the pairing between  $\mathfrak{g}$  and  $\mathfrak{g}^*$  is an invariant scalar product on the Lie algebra  $(\mathfrak{p}, [\cdot, \cdot]_{\mathfrak{p}})$ .

We choose a vector space basis  $\{e_i\}$  of  $\mathfrak{g}$  and denote the dual basis<sup>7</sup>  $\{e^i\}$ . We denote the “structural constants” of  $(\mathfrak{g}, \delta, \varphi)$  as follows

$$[e_i, e_j] = c_{ij}^k e_k; \quad \delta(e_i) = \delta_i^{jk} e_j \otimes e_k; \quad \varphi = \varphi^{ijk} e_i \otimes e_j \otimes e_k .$$

The bracket on  $\mathfrak{p}$  is then given by the formulas

$$\begin{aligned} [e_i, e_j]_{\mathfrak{p}} &= c_{ij}^k e_k; & [e^i, e^j]_{\mathfrak{p}} &= \delta_k^{ij} e^k - \varphi^{ijl} e_l; \\ [e_i, e^j]_{\mathfrak{p}} &= c_{ki}^j e^k + \delta_i^{jl} e_l; & [e^i, e_j]_{\mathfrak{p}} &= -c_{kj}^i e^k - \delta_j^{il} e_l . \end{aligned}$$

We denote the inverse of the invariant scalar product on  $\mathfrak{p}$  by  $t$ . That is

$$t := e_i \otimes e^i + e^j \otimes e_j \in \mathfrak{p} \hat{\otimes} \mathfrak{p}$$

is a symmetric  $\mathfrak{p}$ -invariant element of  $\mathfrak{p} \hat{\otimes} \mathfrak{p}$ . Using it, we equip  $\mathfrak{p}$  with the associated quasi-Lie bialgebra structure as in the definition 4.4. Note that  $\mathfrak{g}$  is not a sub-quasi-Lie-bialgebra of  $\mathfrak{p}$  because the cobracket is trivial on  $\mathfrak{p}$  but possibly not on  $\mathfrak{g}$ .

**Lemma 4.5.** *Let  $\mathfrak{p}'$  be the quasi-Lie bialgebra that we get from  $\mathfrak{p}$  via twisting by*

$$f := \frac{1}{2}(e_i \otimes e^i - e^j \otimes e_j) .$$

*Then  $\mathfrak{g}$  is a sub-quasi-Lie-bialgebra of  $\mathfrak{p}'$ .*

*Proof.* First we show that  $\mathfrak{g}$  is closed under the cobracket  $\delta_{\mathfrak{p}'}$  and that the restriction  $\delta_{\mathfrak{p}'}|_{\mathfrak{g}} = \delta$ . Let  $r = e_i \otimes e^i = t/2 + f$ . From (4.13) we have

$$\begin{aligned} \delta_{\mathfrak{p}'}(e_i) &= \delta_{\mathfrak{p}}(e_i) + [e_i \otimes 1 + 1 \otimes e_i, f] = \frac{1}{2}[e_i \otimes 1 + 1 \otimes e_i, r - r^{op}] = \\ &= \frac{1}{2} \left( [e_i \otimes 1 + 1 \otimes e_i, r] - [e_i \otimes 1 + 1 \otimes e_i, r]^{op} \right) \\ [e_i \otimes 1 + 1 \otimes e_i, r] &= [e_i \otimes 1 + 1 \otimes e_i, e_j \otimes e^j] = \\ &= \begin{array}{l} [e_i, e_j] \otimes e^j \\ + e_j \otimes [e_i, e^j] \end{array} \quad \left| \begin{array}{l} = c_{ij}^k e_k \otimes e^j \\ = c_{ki}^j e_j \otimes e^k + \delta_i^{jl} e_j \otimes e_j \end{array} \right. \\ &= \delta(e_i) \end{aligned}$$

Next we want to show that  $\varphi_{\mathfrak{p}'} = \varphi$ . By the formula (4.14) (using that  $\delta_{\mathfrak{p}} = 0$ ) we have

$$\varphi_{\mathfrak{p}'} = -CYB(t/2) - CYB(f) = -CYB(t/2 + f) = -CYB(r).$$

<sup>6</sup>We equip  $\mathfrak{g}$  with the discrete and  $\mathfrak{g}^*$  with the corresponding strong topology (see the subsection A.4).

<sup>7</sup>Elements of  $\mathfrak{g}^*$  are expressed as possibly infinite linear combinations of  $\{e^i\}$ . We understand such infinite sums in topological sense.

The middle equality follows from the identity  $[t^{12}, x^1 + x^2] = 0$  for every  $x \in \mathfrak{p}$  (invariance of  $t$ ), which, together with the skew-symmetry of  $f$ , implies that the mixed term

$$[t^{12}, f^{13}] + [t^{12}, f^{23}] + [t^{13}, f^{23}] + [f^{12}, t^{13}] + [f^{12}, t^{23}] + [f^{13}, t^{23}]$$

vanishes.

We have

$$\begin{aligned} -\phi_{\mathfrak{p}'} &= CYB(r, r) = [r^{12}, r^{13}] + [r^{12}, r^{23}] + [r^{13}, r^{23}] \\ &= [e_i, e_j] \otimes e^i \otimes e^j + e_i \otimes [e^i, e_j] \otimes e^j + e_i \otimes e_j \otimes [e^i, e^j] \\ &= c_{ij}^k e_k \otimes e^i \otimes e^j + (c_{jk}^i e_i \otimes e^k \otimes e^j - \delta_j^{ik} e_i \otimes e_k \otimes e^j) \\ &\quad + (\delta_k^{ij} e_i \otimes e_j \otimes e^k - \phi^{ijk} e_i \otimes e_j \otimes e_k) \\ &= -\phi^{ijk} e_i \otimes e_j \otimes e_k = -\phi, \end{aligned}$$

as we wanted to show.  $\square$

## 5. FROM CATEGORIES TO QUASI-BIALGEBRAS

We assume that all our categories have strict unit objects. By  $\mathcal{V}$  we denote the category of vector spaces but the assertions of this section hold also if we replace  $\mathcal{V}$  by  $\mathcal{V}^{\text{cpl}}$  or  $\mathcal{V}_{\mathbb{K}[[\hbar]]}^{\text{cpl}}$  and  $\otimes$  by  $\hat{\otimes}$ .

**Definition 5.1.** A functor  $F : \mathcal{C} \rightarrow \mathcal{D}$  between two monoidal categories is a *quasi-monoidal functor* if it is equipped with  $\mathcal{D}$ -morphisms

$$\lambda_0 : I_{\mathcal{D}} \rightarrow F(I_{\mathcal{C}}) \quad \text{and} \quad \lambda_{M,N} : FM \otimes FN \rightarrow F(M \otimes N)$$

natural in  $M, N \in \text{ob}(\mathcal{C})$ , such that the following diagrams commute:

$$(5.1) \quad \begin{array}{ccc} FM \otimes F(I_{\mathcal{C}}) & \xrightarrow{\lambda_{M,I}} & F(M \otimes I_{\mathcal{C}}) & F(I_{\mathcal{C}}) \otimes FM & \xrightarrow{\lambda_{I,M}} & F(I_{\mathcal{C}} \otimes M) \\ \uparrow \text{id}_{FM} \otimes \lambda_0 & & \downarrow = & \uparrow \lambda_0 \otimes \text{id}_{FM} & & \downarrow = \\ FM \otimes I_{\mathcal{D}} & \xrightarrow{=} & FM & I_{\mathcal{D}} \otimes FM & \xrightarrow{=} & FM \end{array}$$

The functor  $F$  will be called *strong quasi-monoidal*, if the maps  $\lambda_0$  and  $\lambda_{M,N}$  are isomorphisms.

**Lemma 5.2.** Let  $\mathcal{C}$  be a monoidal category and  $F : \mathcal{C} \rightarrow \mathcal{V}$  a strong quasi-monoidal functor with the property that the obvious algebra homomorphism<sup>8</sup>

$$(5.2) \quad \Theta : \left( \text{End}(\mathcal{C} \xrightarrow{F} \mathcal{V}) \right)^{\otimes k} \longrightarrow \text{End}(\mathcal{C}^{\times k} \xrightarrow{F^{\times k}} \mathcal{V}^{\times k} \xrightarrow{\otimes} \mathcal{V})$$

is an isomorphism  $\forall k$ . Then  $\text{End}(F)$  is a quasi-bialgebra. If  $\mathcal{C}$  is braided, then  $\text{End}(F)$  becomes a quasi-triangular quasi-bialgebra.

<sup>8</sup>Note that this homomorphism does not depend on the monoidal structure of  $\mathcal{C}$  and  $F$ , just on  $F$  as a functor.

*Proof.* The composition  $\circ$  turns  $\text{End}(F)$  into an algebra. We want to get the other parts of the bialgebra structure.

The monoidal structure on  $F$  consists of maps  $\lambda_{M,N} : F(M) \otimes F(N) \xrightarrow{\cong} F(M \otimes N)$  and  $\lambda_0 : F(I) \rightarrow \mathbb{K}$  where  $I \in \text{ob}(\mathcal{C})$  and  $\mathbb{K} \in \text{ob}(\mathcal{V})$  are the unit objects. Let's denote by  $*$  the category having just one object and one morphism and by

$$\iota_I : * \rightarrow \mathcal{C} \quad \text{and} \quad \iota_{\mathbb{K}} : * \rightarrow \mathcal{V}$$

the functors mapping the unique object of  $*$  to  $I$  and  $\mathbb{K}$  respectively. One can now regard both  $\lambda_{M,N}$  and  $\lambda_0$  as natural transformations:<sup>9</sup>

$$\begin{array}{ccc} \mathcal{C} \times \mathcal{C} & \xrightarrow{\otimes} & \mathcal{C} \\ F \times F \downarrow & \nearrow \lambda \cong & \downarrow F \\ \mathcal{V} \times \mathcal{V} & \xrightarrow{\otimes} & \mathcal{V} \end{array} = \begin{array}{ccc} * & \xrightarrow{\iota_I} & \mathcal{C} \\ \downarrow & \nearrow \lambda_0 \cong & \downarrow F \\ * & \xrightarrow{\iota_{\mathbb{K}}} & \mathcal{V} \end{array}$$

Given  $\alpha \in \text{End}(F)$ , we can define

$$\begin{aligned} \Delta(\alpha) &\in \text{End}(\mathcal{C} \times \mathcal{C} \xrightarrow{F \times F} \mathcal{V} \times \mathcal{V} \xrightarrow{\otimes} \mathcal{V}) \cong \text{End}(F) \otimes \text{End}(F) \\ \varepsilon(\alpha) &\in \text{End}(\iota_{\mathbb{K}}) \cong \mathbb{K} \end{aligned}$$

as the following compositions of natural transformations:

$$\begin{array}{ccc} \mathcal{C} \times \mathcal{C} & & * \\ \swarrow F \times F & \downarrow \otimes & \searrow F \times F \\ \mathcal{V} \times \mathcal{V} & \xrightarrow{\lambda} \mathcal{C} & \xrightarrow{\lambda^{-1}} \mathcal{V} \times \mathcal{V} \\ \swarrow \otimes & \downarrow F(\alpha) & \searrow \otimes \\ \mathcal{V} & & \mathcal{V} \end{array} = \begin{array}{ccc} * & & * \\ \swarrow = & \downarrow \iota_I & \searrow = \\ * & \xrightarrow{\lambda_0} \mathcal{C} & \xrightarrow{\lambda_0^{-1}} * \\ \swarrow \iota_{\mathbb{K}} & \downarrow F(\alpha) & \searrow \iota_{\mathbb{K}} \\ \mathcal{V} & & \mathcal{V} \end{array}$$

It's obvious that  $\Delta$  and  $\varepsilon$  are homomorphisms of algebras — they are just compositions of algebra homomorphisms

$$\begin{aligned} \Delta : \text{End}(F) &\rightarrow \text{End}(F \circ \otimes) \rightarrow \text{End}(\otimes \circ (F \times F)) \xrightarrow{\Theta^{-1}} (\text{End}(F))^{\otimes 2} \\ \varepsilon : \text{End}(F) &\rightarrow \text{End}(F \circ \iota_I) \rightarrow \text{End}(\iota_{\mathbb{K}}) \cong \mathbb{K}. \end{aligned}$$

<sup>9</sup>In the second diagram, one can think of the top  $*$  as  $\mathcal{C}^{\times 0}$ , of the bottom  $*$  as  $\mathcal{V}^{\times 0}$  and of the identity between them as  $F^{\times 0}$ . This way the diagram for  $\lambda_0$  becomes analogous to the one for  $\lambda_{M,N}$ .

We also need the ‘‘associator’’  $\Phi \in (\text{End}(F))^{\otimes 3}$ . On each face of the cube

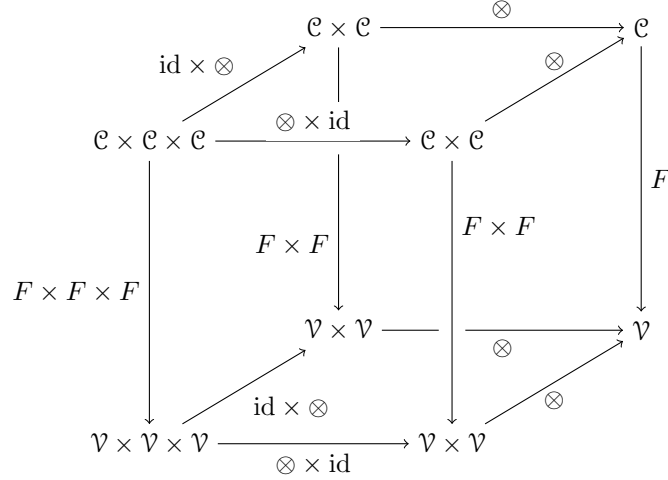

we have a natural isomorphism. If we compose all of them we get an automorphism of

$$c \times c \times c \xrightarrow{F \times F \times F} v \times v \times v \xrightarrow{\otimes^{(3)}} v$$

that corresponds via  $\Theta^{-1}$  to an element  $\Phi \in (\text{End}(F))^{\otimes 3}$ .

We should now prove that our  $\Delta$ ,  $\varepsilon$  and  $\Phi$  satisfy the axioms of a quasi-bialgebra. First, it is clear from the cube-diagram that

$$((\Delta \otimes \text{id}) \circ \Delta) \alpha, ((\text{id} \otimes \Delta) \circ \Delta) \alpha \in \text{End}(c \times c \times c \rightarrow v \times v \times v \xrightarrow{\otimes} v)$$

differ by a conjugation by  $\Phi$ .

The next thing to check is the pentagon relation. The pentagon axiom in the monoidal category  $\mathcal{C}$  means the following equality of two natural transformations:

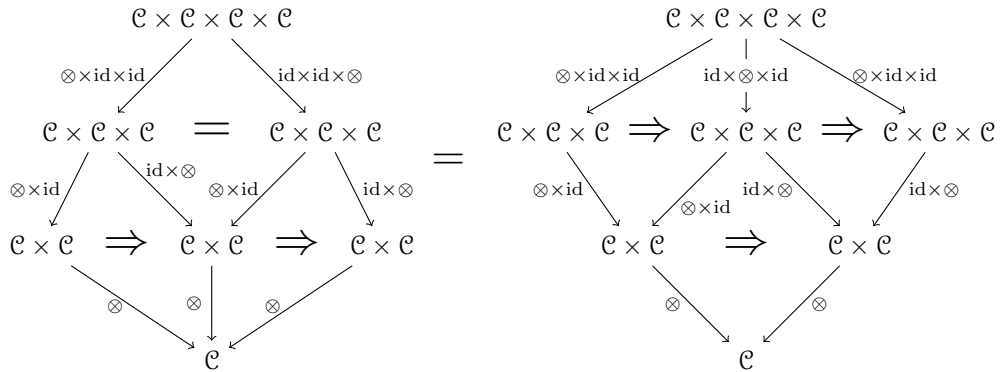

If we consider the first of these diagrams as top base face of a 3-dimensional prism with vertical arrows formed by the functors  $F$ , we get a polyhedron whose faces correspond to some natural isomorphisms. Composing all of them we get an endomorphism of the functor

$$c \times c \times c \times c \xrightarrow{F \times F \times F \times F} v \times v \times v \times v \xrightarrow{\otimes^{(4)}} v$$

that corresponds to an element of  $(\text{End}(F))^{\otimes 4}$ . From the second diagram we get another such element and the above equality gives us equality of the two. This should be the pentagon axiom of the bialgebra definition.

To check the axioms for  $\varepsilon$ , let's rewrite the diagrams (5.1) as equalities between natural transformations:

$$(5.3) \quad \begin{array}{ccccccc} \mathcal{C} & \xrightarrow{=} & \mathcal{C} \times * & \xrightarrow{\text{id}_{\mathcal{C}} \times \iota_I} & \mathcal{C} \times \mathcal{C} & \xrightarrow{\otimes} & \mathcal{C} \\ \downarrow F & \cong & \downarrow F \times \text{id}_* & \nearrow \text{id}_F \times \lambda_0 \cong & \downarrow F \times F & \nearrow \lambda \cong & \downarrow F = \text{id}_F \\ \mathcal{V} & \xrightarrow{=} & \mathcal{V} \times * & \xrightarrow{\text{id}_{\mathcal{C}} \times \iota_{\mathbb{K}}} & \mathcal{V} \times \mathcal{V} & \xrightarrow{\otimes} & \mathcal{V} \end{array}$$

$$(5.4) \quad \begin{array}{ccccccc} \mathcal{C} & \xrightarrow{=} & * \times \mathcal{C} & \xrightarrow{\iota_I \times \text{id}_{\mathcal{C}}} & \mathcal{C} \times \mathcal{C} & \xrightarrow{\otimes} & \mathcal{C} \\ \downarrow F & \cong & \downarrow \text{id}_* \times F & \nearrow \lambda_0 \times \text{id}_F \cong & \downarrow F \times F & \nearrow \lambda \cong & \downarrow F = \text{id}_F \\ \mathcal{V} & \xrightarrow{=} & * \times \mathcal{V} & \xrightarrow{\iota_{\mathbb{K}} \times \text{id}_{\mathcal{C}}} & \mathcal{V} \times \mathcal{V} & \xrightarrow{\otimes} & \mathcal{V} \end{array}$$

We get (4.3) directly from (5.4) and (5.3). Really, if  $\alpha \in \text{End}(F)$  then  $((\varepsilon \otimes \text{id}) \circ \Delta)(\alpha)$  corresponds to conjugation of  $\alpha$  by the left hand side of (5.4). So from (5.4) we get that it is just  $\alpha$ .

In order to see (4.4) recall that an axiom of monoidal categories states that the natural transformation

$$(5.5) \quad \begin{array}{c} \mathcal{C} \times \mathcal{C} \xrightarrow{=} \mathcal{C} \times * \times \mathcal{C} \xrightarrow{\text{id} \times \iota_I \times \text{id}} \mathcal{C} \times \mathcal{C} \times \mathcal{C} \\ \begin{array}{ccc} & \mathcal{C} \times \mathcal{C} & \\ \text{id} \times \otimes \nearrow & & \searrow \otimes \\ & \mathcal{C} \times \mathcal{C} & \\ \otimes \times \text{id} \searrow & & \nearrow \otimes \\ & \mathcal{C} \times \mathcal{C} & \end{array} \\ \phi \Uparrow \cong \end{array}$$

is equal to the identity on the functor  $\mathcal{C} \times \mathcal{C} \xrightarrow{\otimes} \mathcal{C}$ . The left hand side of (4.4) corresponds to the endomorphism of  $\mathcal{C} \times \mathcal{C} \xrightarrow{F \times F} \mathcal{V} \times \mathcal{V} \xrightarrow{\otimes} \mathcal{V}$  that we get as a

composition of natural isomorphisms on the surface of the following diagram:

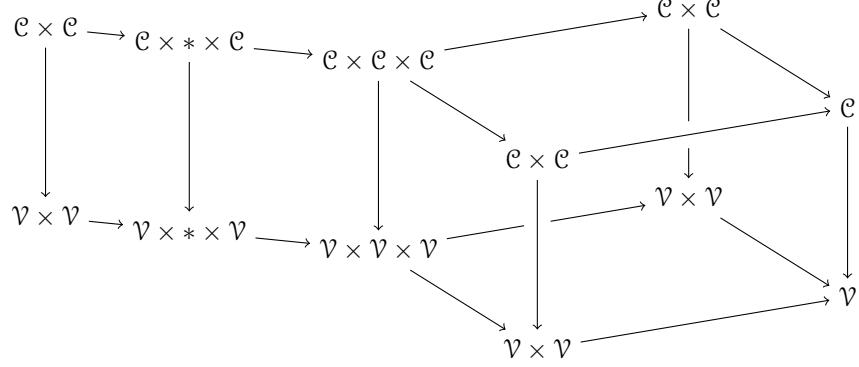

One sees that this surface is basically composed of diagrams (5.3), (5.4) and (5.5) (and one  $\lambda$  and  $\lambda^{-1}$ ) and thus the composition is just the identity on  $\mathcal{C} \times \mathcal{C} \xrightarrow{F \times F} \mathcal{V} \times \mathcal{V} \xrightarrow{\otimes} \mathcal{V}$ .

In the second part of our lemma, we suppose that we have a braiding:<sup>10</sup>

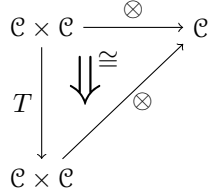

The composition of natural isomorphisms on the faces of

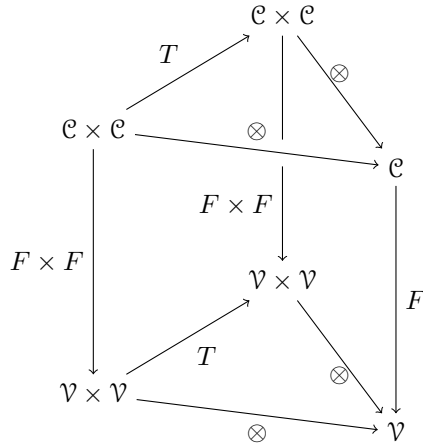

provides us with an automorphism of  $\mathcal{C} \times \mathcal{C} \xrightarrow{F \times F} \mathcal{V} \times \mathcal{V} \xrightarrow{\otimes} \mathcal{V}$  that corresponds to an  $R$ -matrix  $R \in (\text{End}(F))^{\otimes 2}$ . This turns our quasi-bialgebra into a quasi-triangular one.  $\square$

<sup>10</sup> $T$  denotes the functor switching the two arguments.

**Lemma 5.3.** *The assignment from the previous lemma:*

$$\begin{aligned} \{\text{strong quasi-monoidal functors to } \mathcal{V} \text{ s.t. (5.2) is iso}\} &\rightarrow \{\text{quasi-bialgebras}\} \\ (\mathcal{C} \xrightarrow{F} \mathcal{V}) &\mapsto \text{End}(F) \end{aligned}$$

is functorial in the sense that a strong monoidal (not quasi-monoidal) functor  $G$  s.t. the diagram of quasi-monoidal functors

$$\begin{array}{ccc} \mathcal{C}_1 & \xrightarrow{G} & \mathcal{C}_2 \\ F_1 \searrow & & \swarrow F_2 \\ & \mathcal{V} & \end{array}$$

commutes, induces a quasi-bialgebra morphism  $\text{End}(F_2) \xrightarrow{G^*} \text{End}(F_1)$ .

*Proof.* By the equality between quasi-monoidal functors  $F_1 = F_2 \circ G$  we mean also that the quasi-monoidal structure on the functor  $F_1 = F_2 \circ G$  is given by composition of the quasi-monoidal structures that is by the natural transformation

$$\begin{array}{ccc} \mathcal{C}_1 \times \mathcal{C}_1 & \xrightarrow{\otimes} & \mathcal{C}_1 \\ G \times G \downarrow & \mu \nearrow & \downarrow G \\ \mathcal{C}_2 \times \mathcal{C}_2 & \xrightarrow{\otimes} & \mathcal{C}_2 \\ F_2 \times F_2 \downarrow & \lambda \nearrow & \downarrow F_2 \\ \mathcal{V} \times \mathcal{V} & \xrightarrow{\otimes} & \mathcal{V} \end{array}$$

Now the equality  $\Delta(G^*\alpha) = (G^* \otimes G^*)(\Delta\alpha)$  corresponds to the obvious equality of the two natural transformations:

$$\begin{array}{ccc} \begin{array}{ccccc} & & \mathcal{C}_1 \times \mathcal{C}_1 & & \\ & G \times G \swarrow & \downarrow \otimes & \searrow G \times G & \\ \mathcal{C}_2 \times \mathcal{C}_2 & \xrightarrow{\mu} & \mathcal{C}_1 & \xrightarrow{\mu^{-1}} & \mathcal{C}_2 \times \mathcal{C}_2 \\ F_2 \times F_2 \downarrow & \otimes & \downarrow G & \otimes & \downarrow F_2 \times F_2 \\ \mathcal{V} \times \mathcal{V} & \xrightarrow{\lambda} & \mathcal{C}_2 & \xrightarrow{\lambda^{-1}} & \mathcal{V} \times \mathcal{V} \\ & \otimes & \downarrow F_2 & \otimes & \\ & & \mathcal{V} & & \end{array} & = & \begin{array}{ccccc} & & \mathcal{C}_1 \times \mathcal{C}_1 & & \\ & G \times G \downarrow & & & \\ & \mathcal{C}_2 \times \mathcal{C}_2 & & & \\ F_2 \times F_2 \swarrow & \otimes & \downarrow G & \searrow F_2 \times F_2 & \\ \mathcal{V} \times \mathcal{V} & \xrightarrow{\lambda} & \mathcal{C}_2 & \xrightarrow{\lambda^{-1}} & \mathcal{V} \times \mathcal{V} \\ & \otimes & \downarrow F_2 & \otimes & \\ & & \mathcal{V} & & \end{array} \end{array}$$

In order to show  $\Phi_1 = (G^* \otimes G^* \otimes G^*)(\Phi_2)$  one draws the diagram

$$\begin{array}{ccccc}
 & & \mathcal{C}_2 \times \mathcal{C}_2 & \xrightarrow{\otimes} & \mathcal{C}_2 \\
 & \text{id} \times \otimes & \uparrow & & \uparrow \otimes \\
 \mathcal{C}_2 \times \mathcal{C}_2 \times \mathcal{C}_2 & \xrightarrow{\otimes \times \text{id}} & \mathcal{C}_2 \times \mathcal{C}_2 & & \mathcal{C}_2 \\
 \downarrow G \times G \times G & & \downarrow G \times G & & \downarrow G \\
 & \text{id} \times \otimes & \mathcal{C}_1 \times \mathcal{C}_1 & \xrightarrow{\otimes} & \mathcal{C}_1 \\
 & & \uparrow & & \uparrow \otimes \\
 \mathcal{C}_1 \times \mathcal{C}_1 \times \mathcal{C}_1 & \xrightarrow{\otimes \times \text{id}} & \mathcal{C}_1 \times \mathcal{C}_1 & & \mathcal{C}_1 \\
 \downarrow F_2 \times F_2 \times F_2 & & \downarrow F_2 \times F_2 & & \downarrow F_2 \\
 & & \mathcal{V} \times \mathcal{V} & \xrightarrow{\otimes} & \mathcal{V} \\
 & \text{id} \times \otimes & \uparrow & & \uparrow \otimes \\
 \mathcal{V} \times \mathcal{V} \times \mathcal{V} & \xrightarrow{\otimes \times \text{id}} & \mathcal{V} \times \mathcal{V} & & \mathcal{V}
 \end{array}$$

Now  $\Phi_1$  corresponds to the composition of the natural transformations on the outer faces of the union of the two cubes and  $\Phi_2$  to the composition of the faces of the bottom one. The monoidality of  $G$  means that the composition of the faces of the upper cube is the identity. So one gets precisely  $\Phi_1 = (G^* \otimes G^* \otimes G^*)(\Phi_2)$ .  $\square$

*Remark 5.4.* There is a neat way to describe the quasi-bialgebra structure on the algebra  $A := \text{End}(F)$  in Lemma 5.2. Since  $\text{End}(F)$  acts on each  $FM$ ,  $M \in \text{ob}(\mathcal{C})$ , we can lift  $F$  to a functor  $\tilde{F} : \mathcal{C} \rightarrow A\text{-Mod}$  to the category of  $A$ -modules. Any quasi-bialgebra structure on  $A$  makes  $A\text{-Mod}$  into a monoidal category. The one from Lemma 5.2 is the one that ensures that  $\tilde{F}$  becomes a monoidal functor (with respect to the monoidal structure given by the same maps that define the quasi-monoidal structure of  $F$ ).

For the proof one just realizes that  $A = \text{End}(A\text{-Mod} \xrightarrow{\text{forg}} \mathcal{V})$  and that the monoidality of  $\tilde{F}$  implies that the bijection

$$A = \text{End}(A\text{-Mod} \xrightarrow{\text{forg}} \mathcal{V}) \xrightarrow{\tilde{F}^*} \text{End}(F)$$

is a homomorphism of quasi-bialgebras by Lemma 5.3.

**Lemma 5.5.** *Let  $\mathcal{C}$  be a category enriched over  $\mathcal{V}$  and let  $C \in \text{ob}(\mathcal{C})$ . Then the functor represented by  $C$*

$$F : \mathcal{C} \rightarrow \mathcal{V}, Y \mapsto \mathcal{C}(C, Y)$$

satisfies that  $\Theta$  in (5.2) is an isomorphism.

*Proof.* To keep the notations simple we show that  $\Theta$  is an isomorphism for  $k = 2$ . Denote by  $\mathcal{C} \otimes \mathcal{C}$  the category whose objects and morphism are

$$\begin{aligned} \text{ob}(\mathcal{C} \otimes \mathcal{C}) &:= \text{ob}(\mathcal{C}) \times \text{ob}(\mathcal{C}) \\ \mathcal{C} \otimes \mathcal{C}((X_1, X_2), (Y_1, Y_2)) &:= \mathcal{C}(X_1, Y_1) \otimes \mathcal{C}(X_2, Y_2) \end{aligned}$$

with the obvious compositions. One has a functor  $\mathcal{C} \times \mathcal{C} \xrightarrow{J} \mathcal{C} \otimes \mathcal{C}$ . We further denote by

$$G : \mathcal{C} \otimes \mathcal{C} \rightarrow \mathcal{V} : (Y_1, Y_2) \mapsto \mathcal{C} \otimes \mathcal{C}((C, C), (Y_1, Y_2))$$

the functor represented by  $(C, C)$ . Then the diagram

$$\begin{array}{ccc} \mathcal{C} \times \mathcal{C} & \xrightarrow{J} & \mathcal{C} \otimes \mathcal{C} \\ F \times F \downarrow & & \downarrow G \\ \mathcal{V} \times \mathcal{V} & \xrightarrow{\otimes} & \mathcal{V} \end{array}$$

is strictly commutative so one has an equality

$$\text{End}(\mathcal{C} \otimes \mathcal{C} \xrightarrow{F \times F} \mathcal{V} \times \mathcal{V} \xrightarrow{\otimes} \mathcal{V}) = \text{End}(\mathcal{C} \times \mathcal{C} \xrightarrow{J} \mathcal{C} \otimes \mathcal{C} \xrightarrow{G} \mathcal{V}).$$

Using this we can factorize  $\Theta$  as a composition:

$$\begin{array}{ccc} (\text{End}(\mathcal{C} \xrightarrow{F} \mathcal{V}))^{\otimes 2} & \xrightarrow{\Theta} & \text{End}(\mathcal{C} \times \mathcal{C} \xrightarrow{J} \mathcal{C} \otimes \mathcal{C} \xrightarrow{G} \mathcal{V}) \\ & \searrow & \uparrow J^* \\ & & \text{End}(\mathcal{C} \otimes \mathcal{C} \xrightarrow{G} \mathcal{V}) \end{array}$$

It is easy to see that the vertical map is an iso. By Yoneda we have

$$(\text{End}(\mathcal{C} \xrightarrow{F} \mathcal{V}))^{\otimes 2} = (\mathcal{C}(C, C))^{\otimes 2}$$

and also

$$\text{End}(\mathcal{C} \otimes \mathcal{C} \xrightarrow{G} \mathcal{V}) = \mathcal{C} \otimes \mathcal{C}((C, C), (C, C)) = (\mathcal{C}(C, C))^{\otimes 2}$$

so we see that the oblique map is also an iso.  $\square$

**Lemma 5.6.** *Let  $\mathcal{C} \xrightarrow{F} \mathcal{V}$  be a functor satisfying the condition of Lemma 5.2. Let  $(\lambda_0, \lambda)$  and  $(\lambda_0, \lambda')$  be two strong quasi-monoidal structures on  $F$  with the same  $\lambda_0$ . Then  $\lambda, \lambda' : \otimes \circ (F \times F) \xrightarrow{\cong} F \circ \otimes$  differ by an invertible element*

$$J \in \text{End}(\otimes \circ (F \times F)) = \text{End}(F) \otimes \text{End}(F).$$

and the two quasi-bialgebra structures one gets on  $\text{End}(F)$  differ by the twist by  $J$ .

*Remark 5.7.* Actually, we will use the lemma (5.6) in a slightly different context. We will have two quasi-monoidal functors  $(F, \lambda), (G, \mu) : \mathcal{C} \rightarrow \mathcal{V}$  and a natural isomorphism  $\alpha : F \rightarrow G$ , that will not be monoidal. The two quasi-bialgebras

$\text{End}(F, \lambda)$  and  $\text{End}(G, \mu)$  can be considered to be the same as algebras thanks to  $\alpha$ , but their quasi-bialgebra structures differ by a twist by the element<sup>11</sup>

$$FX \otimes FY \xrightarrow{\alpha_X \otimes \alpha_Y} GX \otimes GY \xrightarrow{\mu_{X,Y}} G(X \otimes Y) \xrightarrow{\alpha_{X \otimes Y}^{-1}} F(X \otimes Y) \xrightarrow{\lambda_{X,Y}^{-1}} FX \otimes FY$$

in  $\text{End}(\otimes \circ (F \times F)) = \text{End}(F) \otimes \text{End}(F)$ .

## 6. MODULES IN BRAIDED MONOIDAL CATEGORIES

**6.1. Category of  $A$ -modules.** In this subsection,  $\mathcal{C}$  will denote a preabelian braided monoidal category satisfying that for any  $X \in \text{ob}(\mathcal{C})$  the functor  $\_ \otimes X : \mathcal{C} \rightarrow \mathcal{C}$  preserves finite colimits. We also fix a commutative (w.r.t. the braiding in  $\mathcal{C}$ ) algebra (i.e. a monoid)  $A$  in  $\mathcal{C}$ .

**Notation 6.1.** If  $\mathcal{C}$  is a monoidal category and  $A$  an algebra in  $\mathcal{C}$ , we denote by  $A\text{-Mod}(\mathcal{C})$  and  $\text{Mod-}A(\mathcal{C})$  the categories of left and right  $A$ -modules in  $\mathcal{C}$ .

**Definition 6.2.** Let  $M$  be a right and  $N$  a left  $A$ -module in  $\mathcal{C}$ . We define  $M \otimes_A N$  as an object in  $\mathcal{C}$  together with an  $A$ -bilinear map  $M \otimes N \rightarrow M \otimes_A N$  that is universal in the usual sense.

Since  $\mathcal{C}$  is preabelian, we can reformulate this as follows:

**Definition 6.3.** Let  $M \otimes A \xrightarrow{\mu} M$  and  $A \otimes N \xrightarrow{\nu} N$  be the  $A$ -module structures on  $M$  and  $N$ .  $M \otimes_A N$  is the cokernel of

$$M \otimes A \otimes N \xrightarrow{(\text{id} \otimes \nu) - (\mu \otimes \text{id})} M \otimes N.$$

**Proposition 6.4.** If  $M \in \text{ob}(\text{Mod-}A)$ ,  $N \in \text{ob}(A\text{-Mod})$ ,  $X \in \text{ob}(\mathcal{C})$  then

$$M \otimes_A (N \otimes X) \cong (M \otimes_A N) \otimes X$$

*Proof.* Just use that  $\_ \otimes X$  preserves cokernels and the definition 6.3. □

**Corollary 6.5.** Assume that on  $N$  we have also a right  $A$ -module structure, commuting with the left one. Then one can define a right  $A$ -module structure on  $M \otimes_A N$  by the following composition:

$$(M \otimes_A N) \otimes A \cong M \otimes_A (N \otimes A) \rightarrow M \otimes_A N.$$

If  $N$  is just a right  $A$ -module, we can use the commutativity of  $A$  and the braiding in  $\mathcal{C}$  to give it a commuting left  $A$ -module structure:

$$\begin{array}{c} N \\ | \\ \curvearrowright \\ A \end{array} := \begin{array}{c} N \\ | \\ \curvearrowleft \\ A \end{array}$$

This together with the corollary 6.5 enables us to see  $\otimes_A$  as a monoidal structure on  $\text{Mod-}A$ .

**Proposition 6.6.** The functor  $\_ \otimes A : \mathcal{C} \rightarrow \text{Mod-}A$  is strong monoidal.

<sup>11</sup>This map measures the failure of  $\alpha$  to be monoidal.

*Proof.* We want to identify  $(M \otimes A) \otimes_A (N \otimes A)$  with  $(M \otimes N) \otimes A$ . For that we have just to specify a universal  $A$ -bilinear  $\mathcal{C}$ -morphism

$$(M \otimes A) \otimes (N \otimes A) \rightarrow (M \otimes N) \otimes A .$$

We take this:

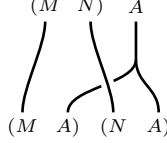

□

Recall that we assumed  $\mathcal{C}$  preabelian, braided monoidal category, s.t. the tensor product with any fixed object of  $\mathcal{C}$  preserves finite colimits. One can ask whether  $\mathbf{Mod}\text{-}A$  is also like that.

**Proposition 6.7.**  *$\mathbf{Mod}\text{-}A$  is a preabelian monoidal category satisfying that the functor  ${}_-\otimes_A M : \mathbf{Mod}\text{-}A \rightarrow \mathbf{Mod}\text{-}A$  preserves finite colimits.*

*If  $\mathcal{C}$  was symmetric-monoidal,  $\mathbf{Mod}\text{-}A$  is also symmetric-monoidal.*

*If  $\mathcal{C}$  was a  $\mathcal{V}^{\text{top}}$ -category (definition A.19) or a  $\mathcal{V}_{\mathbb{K}[[\hbar]]}^{\text{h-cpl}}$ -category (the subsection E.1) then  $\mathbf{Mod}\text{-}A$  also stays like that.*

*Proof.* Obvious. □

**6.2. Category of free  $A$ -modules.** Let now  $\mathcal{C}$  be a braided monoidal category (we don't impose the conditions of Subsection 6.1) and  $A$  a commutative algebra in it.

We take  $\text{ob}(\mathbf{Free}\text{-}A) := \text{ob}(\mathcal{C})$  but we will denote the objects in  $\mathbf{Free}\text{-}A$  as  $X \otimes A$  for  $X \in \text{ob}(\mathcal{C})$ . The hom sets are

$$\mathbf{Free}\text{-}A(X \otimes A, Y \otimes A) := \mathcal{C}(X, Y \otimes A)$$

with the composition

$$(6.1) \quad \begin{array}{c} Z \quad A \\ \diagdown \quad / \\ \boxed{g} \\ | \\ Y \end{array} \circ \begin{array}{c} Y \quad A \\ \diagdown \quad / \\ \boxed{f} \\ | \\ X \end{array} := \begin{array}{c} Z \quad A \\ \diagdown \quad / \\ \boxed{g} \\ | \\ \boxed{f} \\ | \\ X \end{array} .$$

The monoidal structure is denoted again by  $\otimes_A$  and is defined on the objects as  $(X_1 \otimes A) \otimes_A (X_2 \otimes A) := (X_1 \otimes X_2) \otimes A$  and on the morphisms as

$$(6.2) \quad \begin{array}{c} Y_1 \quad A \\ \diagdown \quad / \\ \boxed{f_1} \\ | \\ X_1 \end{array} \otimes_A \begin{array}{c} Y_2 \quad A \\ \diagdown \quad / \\ \boxed{f_2} \\ | \\ X_2 \end{array} := \begin{array}{c} Y_1 \quad Y_2 \quad A \\ \diagdown \quad / \quad / \\ \boxed{f_1} \quad \boxed{f_2} \\ | \quad | \\ X_1 \quad X_2 \end{array}$$

*Remark 6.8.* If we can form also  $\mathbf{Mod}\text{-}A$  then we have an obvious fully-faithful, strong monoidal functor  $\mathbf{Free}\text{-}A \rightarrow \mathbf{Mod}\text{-}A$ . However, an object  $X \otimes A$  in  $\mathbf{Free}\text{-}A$  carries more information than the corresponding  $X \otimes A$  in  $\mathbf{Mod}\text{-}A$ , namely it remembers the object  $X \in \text{ob}(\mathcal{C})$ .

## 7. REPRESENTED FUNCTORS

## 7.1. Karoubi envelope.

**Definition 7.1.** Let  $\mathcal{C}$  be a category. We define a new category  $\text{Split}(\mathcal{C})$  (called the *Karoubi envelope* of  $\mathcal{C}$ ) whose objects are pairs  $(X, p)$  where  $X \in \text{ob}(\mathcal{C})$  and  $p \in \mathcal{C}(X, X)$  satisfying  $p^2 = p$ . Morphisms  $f : (X, p) \rightarrow (Y, q)$  in  $\text{Split}(\mathcal{C})$  are morphisms  $X \xrightarrow{f} Y$  in  $\mathcal{C}$  satisfying  $q \circ f \circ p = f$ . If  $\mathcal{C}$  is a monoidal category then  $\text{Split}(\mathcal{C})$  will be again a monoidal category:

$$(X, p) \otimes (Y, q) := (X \otimes Y, p \otimes q).$$

There is a canonical fully faithful functor  $\mathcal{C} \rightarrow \text{Split}(\mathcal{C}) : X \mapsto (X, \text{id}_X)$ .

Ideologically, one regards an object  $(X, p)$  of  $\text{Split}(\mathcal{C})$  as the image  $\text{Im}(p) \subset X$ , with a complement  $\text{Ker}(p)$  (that is  $X = \text{Im}(p) \oplus \text{Ker}(p)$ ) even if kernels and images don't make sense in  $\mathcal{C}$ . Thus we occasionally call objects of  $\text{Split}(\mathcal{C})$  "direct summands in  $\mathcal{C}$ ".

**Definition 7.2.** We define the functor represented by a direct summand  $(X, p)$  as

$$\mathbf{h}_{(X,p)} : \mathcal{C} \rightarrow \mathbf{Set} : Y \mapsto \text{Hom}_{\text{Split}(\mathcal{C})}((X, p), Y) = \{f \in \mathcal{C}(X, Y) \mid f \circ p = f\}.$$

If  $\mathcal{C}$  is a  $\mathcal{V}^{\text{top}}$ -category (or  $\mathcal{V}_{\mathbb{K}[[\hbar]]}^{\hbar\text{-cpl}}$ -category), we get a functor to  $\mathcal{V}^{\text{top}}$  (or  $\mathcal{V}_{\mathbb{K}[[\hbar]]}^{\hbar\text{-cpl}}$ ).

**Proposition 7.3.**

$$\text{End}(\mathbf{h}_{(X,p)}) = \text{End}_{\text{Split}(\mathcal{C})}((X, p)) = \{f \in \mathcal{C}(X, X) \mid p \circ f \circ p = f\}.$$

*Proof.* Obvious.  $\square$

## 7.2. Quasi-monoidal structure on a represented functor.

**Definition 7.4.** A *quasi-coalgebra* in  $\mathcal{C}$  is an object  $C$  together with two morphisms  $\Delta : C \rightarrow C \otimes C$ ,  $\varepsilon : C \rightarrow I$  satisfying that the two compositions

$$C \xrightarrow{\Delta} C \otimes C \xrightarrow{\text{id} \otimes \varepsilon} C \quad \text{and} \quad C \xrightarrow{\Delta} C \otimes C \xrightarrow{\varepsilon \otimes \text{id}} C$$

are equal to  $\text{id}_C$ . Thus a quasi-coalgebra is a coalgebra that is not necessarily co-associative.

If we assume that  $\mathcal{C}$  is enriched over vector spaces then the functor  $\mathbf{h}_C$  represented by  $C$  will get a quasi-monoidal structure in the following way: the morphism  $\mathbf{h}_C(X) \otimes \mathbf{h}_C(Y) \rightarrow \mathbf{h}_C(X \otimes Y)$  is given by the composition

$$\mathcal{C}(C, X) \otimes \mathcal{C}(C, Y) \xrightarrow{\otimes} \mathcal{C}(C \otimes C, X \otimes Y) \xrightarrow{\Delta^*} \mathcal{C}(C, X \otimes Y)$$

and the morphism  $\mathbb{K} \rightarrow \mathbf{h}_C(I)$  is

$$\mathbb{K} \xrightarrow{1 \mapsto \text{id}_I} \mathcal{C}(I, I) \xrightarrow{\varepsilon^*} \mathcal{C}(C, I).$$

Consequently, if  $(X, p)$  is a quasi-coalgebra in  $\text{Split}(\mathcal{C})$ , the functor represented by it will be quasi-monoidal. Explicitly, if we have morphisms  $\Delta_X : X \rightarrow X \otimes X$ ,  $\varepsilon_X : X \rightarrow I$  satisfying

$$(p \otimes p) \circ \Delta_X \circ p = \Delta_X; \quad \varepsilon_X \circ p = \varepsilon_X \quad \text{and} \\ (\varepsilon_X \otimes \text{id}_X) \circ \Delta_X = (\text{id}_X \otimes \varepsilon_X) \circ \Delta_X = p$$

then we get a natural quasi-monoidal structure on the functor represented by  $(X, p)$ .

*Remark 7.5.* Everything generalizes to  $\mathcal{V}^{\text{top}}$ -categories and  $\mathcal{V}_{\mathbb{K}[[\hbar]]}^{\hbar\text{-cpl}}$ -categories.

## 8. OUR CATEGORIES

8.1. **Categories  $\mathcal{G}$  and  $\mathcal{P}$ .** Denote by  $\mathcal{G}$  and  $\mathcal{P}$  the categories of complete equicontinuous  $\mathfrak{g}$  and  $\mathfrak{p}$  modules. The product  $\hat{\otimes}$  makes them into symmetric monoidal categories. We equip the hom-sets with strong topologies and regard  $\mathcal{G}$  and  $\mathcal{P}$  as  $\mathcal{V}^{\text{top}}$ -categories.

8.2. **Functor  $\heartsuit : \mathcal{G} \rightarrow \mathcal{P}$ .** Given  $M \in \mathcal{G}$ , define the topological vector space  $\heartsuit M := \text{Hom}_{\mathcal{U}\mathfrak{g}}^C(\mathcal{U}\mathfrak{p}, M)$ . We define a left  $\mathcal{U}\mathfrak{p}$ -module structure on  $\heartsuit M$  by

$$(z \triangleright s)(x) := s(xz) \quad \text{for } z, x \in \mathcal{U}\mathfrak{p}, s \in \heartsuit M = \text{Hom}_{\mathcal{U}\mathfrak{g}}^C(\mathcal{U}\mathfrak{p}, M).$$

In fact,  $\heartsuit M$  is complete (Proposition 8.2) and an equicontinuous  $\mathfrak{p}$ -module (corollary D.2) and thus we get a functor  $\heartsuit : \mathcal{G} \rightarrow \mathcal{P}$ .

**Notation 8.1.** Define an algebra  $\hat{S}\mathfrak{g}$  in  $\mathcal{V}^{\text{cp1}}$  as the following limit of discrete commutative algebras:

$$\hat{S}\mathfrak{g} := \varprojlim_k ((S\mathfrak{g})/(S^{>k}\mathfrak{g})) .$$

In other words,  $\hat{S}\mathfrak{g}$  is the algebra of formal power series on  $\mathfrak{g}^*$ .

**Proposition 8.2.** *There is a natural isomorphism of topological vector spaces  $\heartsuit M \cong M \hat{\otimes} \hat{S}\mathfrak{g}$ . In particular,  $\heartsuit M$  is complete.*

*Proof.* We have the following maps:

$$\heartsuit M = \text{Hom}_{\mathcal{U}\mathfrak{g}}^C(\mathcal{U}\mathfrak{p}, M) \xrightarrow{(1)} \text{Hom}_{\mathbb{K}}^C(S\mathfrak{g}^*, M) \xleftarrow{(2)} M \hat{\otimes} (S\mathfrak{g}^*)^* \xlongequal{(3)} M \hat{\otimes} \hat{S}\mathfrak{g}$$

(1) is the restriction map that is a topological isomorphism by the claim D.4. (2) and (3) are also topological isomorphisms by claims A.29 and D.5.  $\square$

**Proposition 8.3.** *The functor  $\heartsuit$  has a monoidal structure*

$$\mathbb{K} \rightarrow \heartsuit \mathbb{K}; \quad \heartsuit M \hat{\otimes} \heartsuit N \rightarrow \heartsuit(M \hat{\otimes} N)$$

given by  $\mathbb{K} \rightarrow \text{Hom}_{\mathcal{U}\mathfrak{g}}^C(\mathcal{U}\mathfrak{p}, M) : 1 \mapsto \varepsilon_{\mathcal{U}\mathfrak{p}}$  and

$$\begin{aligned} \text{Hom}_{\mathcal{U}\mathfrak{g}}^C(\mathcal{U}\mathfrak{p}, M) \hat{\otimes} \text{Hom}_{\mathcal{U}\mathfrak{g}}^C(\mathcal{U}\mathfrak{p}, N) &\rightarrow \text{Hom}_{\mathcal{U}\mathfrak{g}}^C(\mathcal{U}\mathfrak{p}, M \hat{\otimes} N) : \\ (\mathcal{U}\mathfrak{p} \xrightarrow{s} M) \otimes (\mathcal{U}\mathfrak{p} \xrightarrow{t} N) &\mapsto (\mathcal{U}\mathfrak{p} \xrightarrow{\Delta} \mathcal{U}\mathfrak{p} \otimes \mathcal{U}\mathfrak{p} \xrightarrow{s \otimes t} M \otimes N \rightarrow M \hat{\otimes} N) . \end{aligned}$$

*Proof.* Since all the maps in the composition

$$\mathcal{U}\mathfrak{p} \xrightarrow{\Delta} \mathcal{U}\mathfrak{p} \otimes \mathcal{U}\mathfrak{p} \xrightarrow{s \otimes t} M \otimes N \rightarrow M \hat{\otimes} N$$

are  $\mathcal{U}\mathfrak{g}$ -linear and continuous, their composition also is. Thus we really get an element in  $\heartsuit(M \hat{\otimes} N)$ .

One has also to check that the resulting map  $\heartsuit M \hat{\otimes} \heartsuit N \rightarrow \heartsuit(M \hat{\otimes} N)$  is  $\mathcal{U}\mathfrak{p}$ -linear (that is easy) and continuous w.r.t. the strong topologies (it is, because  $\mathcal{V}^{\text{top}}$  is a  $\mathcal{V}^{\text{top}}$ -category and  $\mathcal{U}\mathfrak{p} \xrightarrow{\Delta} \mathcal{U}\mathfrak{p} \otimes \mathcal{U}\mathfrak{p}$  and  $M \otimes N \rightarrow M \hat{\otimes} N$  are continuous).

Coassociativity of  $\mathcal{U}\mathfrak{p} \xrightarrow{\Delta} \mathcal{U}\mathfrak{p} \otimes \mathcal{U}\mathfrak{p}$  implies that this structure is monoidal, not just quasi-monoidal.  $\square$

**8.3. Algebra  $A$ .** One can regard  $\mathbb{K}$  as a commutative algebra in  $\mathcal{G}$ . Since  $\heartsuit$  is a monoidal functor,  $A := \heartsuit \mathbb{K}$  will be a commutative algebra in  $\mathcal{P}$ . Explicitly, the product of  $f, g \in A = \text{Hom}_{\mathcal{U}\mathfrak{g}}^C(\mathcal{U}\mathfrak{p}, \mathbb{K})$  is given by

$$(f \cdot g)(z) = \sum f(z_{(1)}) \cdot g(z_{(2)}) \quad \text{for } z \in \mathcal{U}\mathfrak{p}$$

and the unit is just the augmentation on the universal enveloping algebra  $\varepsilon_{\mathcal{U}\mathfrak{p}} : \mathcal{U}\mathfrak{p} \rightarrow \mathbb{K}$ .

**8.4. Natural epimorphism  $\pi_M : \heartsuit M \rightarrow M$  in  $\mathcal{G}$ .** For  $M \in \mathcal{G}$  we define

$$\pi_M : \heartsuit M = \text{Hom}_{\mathcal{U}\mathfrak{g}}^C(\mathcal{U}\mathfrak{p}, M) \rightarrow M : s \mapsto s(1) .$$

It is a natural transformation between  $\mathcal{G} \xrightarrow{\heartsuit} \mathcal{P} \xrightarrow{\text{forg}} \mathcal{G}$  and  $\mathcal{G} \xrightarrow{\text{id}} \mathcal{G}$ .

**8.5. Augmentation  $\varepsilon_A := \pi_{\mathbb{K}} : A \rightarrow \mathbb{K}$  in  $\mathcal{G}$ .** Explicitly

$$\varepsilon_A : A = \text{Hom}_{\mathcal{U}\mathfrak{g}}^C(\mathcal{U}\mathfrak{p}, \mathbb{K}) \rightarrow \mathbb{K} : s \mapsto s(1) .$$

It is easy to see, that  $\varepsilon_A$  is an augmentation on the algebra  $A$  in  $\mathcal{G}$  (but it is not a morphism in  $\mathcal{P}$ ). On pictures, we denote  $\varepsilon_A$  by .

**8.6. Categories  $\mathcal{A}$  and  $\mathcal{F}$ .** Denote by  $\mathcal{A}$  the category of all right  $A$ -modules and by  $\mathcal{F}$  the category of free right  $A$ -modules in  $\mathcal{P}$  (in the sense of Subsection 6.2). They are symmetric monoidal categories with the monoidal product  $\otimes_A$ .

**8.7. Functor  $\tilde{\heartsuit}$ .** Since any  $M \in \text{ob}(\mathcal{G})$  is a right module over  $\mathbb{K}$  in  $\mathcal{G}$ ,  $\heartsuit M$  will be a right module over  $A$ . Explicitly, if  $f \in A = \text{Hom}_{\mathcal{U}\mathfrak{g}}^C(\mathcal{U}\mathfrak{p}, \mathbb{K})$  and  $s \in \heartsuit M = \text{Hom}_{\mathcal{U}\mathfrak{g}}^C(\mathcal{U}\mathfrak{p}, M)$  we define  $s \triangleleft f \in \heartsuit M$  by

$$(s \triangleleft f)(z) = \sum s(z_{(1)}) \cdot f(z_{(2)}) \quad \text{for } z \in \mathcal{U}\mathfrak{p} .$$

We can thus regard  $\heartsuit$  as a functor:

$$\tilde{\heartsuit} : \mathcal{G} \rightarrow \mathcal{A} .$$

*Remark 8.4.* From the proposition 8.2 we have an isomorphism topological vector spaces  $A \cong \hat{S}\mathfrak{g}$ . Since this isomorphism is essentially the morphism

$$\text{Hom}_{\mathcal{U}\mathfrak{g}}^C(\mathcal{U}\mathfrak{p}, \mathbb{K}) \rightarrow \text{Hom}_{\mathbb{K}}^C(S\mathfrak{g}, \mathbb{K})$$

induced by a coalgebra homomorphism  $S\mathfrak{g} \rightarrow \mathcal{U}\mathfrak{p} = \mathcal{U}\mathfrak{g} \otimes S\mathfrak{g}$ , we see that  $A \cong \hat{S}\mathfrak{g}$  is actually an isomorphism of algebras.

Similarly, if we forget an  $A$ -module  $\heartsuit M \in \text{ob}(\mathcal{P})$  into  $\mathcal{V}^{\text{cpl}}$ , we get an  $A = \hat{S}\mathfrak{g}$ -module in  $\mathcal{V}^{\text{cpl}}$  and the isomorphism  $\heartsuit M \cong M \hat{\otimes} \hat{S}\mathfrak{g}$  from the proposition 8.2 is an isomorphism of  $\hat{S}\mathfrak{g}$ -modules.

Since the monoidal structure  $\heartsuit M \hat{\otimes} \heartsuit N \rightarrow \heartsuit(M \hat{\otimes} N)$  of the functor  $\heartsuit$  is given by an  $A$ -bilinear morphism in  $\mathcal{P}$ , it induces a (strong as we will soon see) monoidal structure  $\tilde{\heartsuit} M \otimes_A \tilde{\heartsuit} N \rightarrow \tilde{\heartsuit}(M \hat{\otimes} N)$  on  $\tilde{\heartsuit}$ .

### 8.8. The main technical theorem.

**Theorem 8.5.** (1)  $\tilde{\heartsuit} : \mathcal{G} \rightarrow \mathcal{A}$  is a strong monoidal and fully faithful functor.  
 (2) If  $M \in \text{ob}(\mathcal{P})$ , there is a natural  $\mathcal{A}$ -isomorphism  $\tilde{\heartsuit} M \cong M \hat{\otimes} A$ . That is, we have a natural monoidal isomorphism:

$$\begin{array}{ccc} & \mathcal{P} & \\ \text{forg} \swarrow & & \searrow \hat{\otimes} A \\ \mathcal{G} & \xrightarrow{\cong} & \mathcal{A} \\ & \tilde{\heartsuit} & \end{array}$$

(3) The above statements give us for  $M, N \in \text{ob}(\mathcal{P})$  an isomorphism

$$\mathcal{G}(M, N) \xrightarrow[\cong]{\tilde{\heartsuit}} \mathcal{A}(\tilde{\heartsuit} M, \tilde{\heartsuit} N) \cong \mathcal{A}(M \hat{\otimes} A, N \hat{\otimes} A) \cong \mathcal{P}(M, N \hat{\otimes} A).$$

Explicitly, (the inverse of) this isomorphism is

$$(8.1) \quad \mathcal{P}(M, N \hat{\otimes} A) \xrightarrow[\cong]{\tilde{\heartsuit}} \mathcal{G}(M, N) : \begin{array}{c} N \quad A \\ \swarrow \quad \searrow \\ \boxed{f} \\ \downarrow \\ M \end{array} \mapsto \begin{array}{c} N \quad \bullet \\ \swarrow \quad \searrow \\ \boxed{f} \\ \downarrow \\ M \end{array}$$

The rest of this subsection is devoted to the proof of the theorem 8.5.

*Remark 8.6.* The category  $\mathcal{V}^{\text{cpl}}$  is not an abelian, just a preabelian category. The fact of having an exact sequence  $A \rightarrow B \rightarrow C \rightarrow 0$  does not determine the topology on  $C$  uniquely. Thus in this section, by saying that such a sequence is (right) exact, we mean that  $C$  is a cokernel of the map  $A \rightarrow B$ . Similarly, a functor will be said to be right-exact (to reflect right-exactness) if it preserves (reflects) cokernels. We believe this abuse makes it more readable.

*Proof that  $\tilde{\heartsuit}$  is strong monoidal.* By the definition 6.3 of the tensor product over  $A$  we need to show that the sequence

$$\heartsuit M \hat{\otimes} A \hat{\otimes} \heartsuit N \rightarrow \heartsuit M \hat{\otimes} \heartsuit N \rightarrow \heartsuit(M \hat{\otimes} N) \rightarrow 0$$

is exact. The forgetful functor  $\mathcal{P} \xrightarrow{\text{forg}} \mathcal{V}^{\text{cpl}}$  reflects right-exactness and so it's enough to see the exactness of the following sequence in  $\mathcal{V}^{\text{cpl}}$  (see the remark 8.4):

$$(M \hat{\otimes} \hat{S}\mathfrak{g}) \hat{\otimes} \hat{S}\mathfrak{g} \hat{\otimes} (N \hat{\otimes} \hat{S}\mathfrak{g}) \rightarrow (M \hat{\otimes} \hat{S}\mathfrak{g}) \hat{\otimes} (N \hat{\otimes} \hat{S}\mathfrak{g}) \rightarrow M \hat{\otimes} N \hat{\otimes} \hat{S}\mathfrak{g} \rightarrow 0.$$

But the last sequence just says that

$$(M \hat{\otimes} \hat{S}\mathfrak{g}) \otimes_{\hat{S}\mathfrak{g}} (N \hat{\otimes} \hat{S}\mathfrak{g}) \cong M \hat{\otimes} N \hat{\otimes} \hat{S}\mathfrak{g}$$

what comes from the proposition 6.6.  $\square$

To prove that  $\tilde{\heartsuit}$  is fully faithful, we introduce a functor  $\clubsuit : \mathcal{A} \rightarrow \mathcal{G}$ . Recall that we have an augmentation  $\varepsilon_A : \text{Forg}_{\mathcal{G}}^{\mathcal{P}} A \rightarrow \mathbb{K}$ . This turns  $\mathbb{K} \in \text{ob}(\mathcal{G})$  into an  $\text{Forg}_{\mathcal{G}}^{\mathcal{P}} A$ -module. If  $M \in \text{ob}(\mathcal{A})$  then  $\text{Forg}_{\mathcal{G}}^{\mathcal{P}} M$  is also an  $\text{Forg}_{\mathcal{G}}^{\mathcal{P}} A$ -module and so we can define

$$\clubsuit : \mathcal{A} \rightarrow \mathcal{G} : M \mapsto \text{Forg}_{\mathcal{G}}^{\mathcal{P}} M \otimes_{\text{Forg}_{\mathcal{G}}^{\mathcal{P}} A} \mathbb{K}.$$

**Claim 8.7.**  $\clubsuit \circ \tilde{\heartsuit} \cong \text{id}_{\mathcal{G}}$ .

*Proof.* We will omit the forgetful functor  $\text{Forg}_{\mathfrak{G}}^{\mathfrak{P}}$  in the notations. As an  $A$ -module,  $\mathbb{K} = A/\text{Ker } \varepsilon_A$  and thus

$$\mathbb{K} \otimes_A \heartsuit M = \heartsuit M / (\heartsuit M \triangleleft \text{Ker}(\varepsilon_A)) .$$

To see that this is naturally isomorphic to  $M$ , we show that the sequence in  $\mathfrak{G}$ :

$$(8.2) \quad \heartsuit M \hat{\otimes} \text{Ker } \varepsilon_A \xrightarrow{\simeq} \heartsuit M \xrightarrow{\pi_M} M \rightarrow 0$$

is exact. If we apply to it the functor  $\mathfrak{G} \xrightarrow{\text{forg}} \mathcal{V}^{\text{cpl}}$ , we get the sequence

$$(8.3) \quad (M \hat{\otimes} \hat{S}\mathfrak{g}) \hat{\otimes} \hat{S}^{>0}\mathfrak{g} \xrightarrow{\text{id}_M \hat{\otimes} \mu_{\hat{S}\mathfrak{g}}} M \hat{\otimes} \hat{S}\mathfrak{g} \rightarrow M \rightarrow 0 .$$

The functor  $\mathfrak{G} \xrightarrow{\text{forg}} \mathcal{V}^{\text{cpl}}$  reflects exactness, so to prove that (8.2) is exact it is enough to show that (8.3) is. But (8.3) is just the image of the obviously exact sequence

$$\hat{S}\mathfrak{g} \hat{\otimes} \hat{S}^{>0}\mathfrak{g} \xrightarrow{\mu_{\hat{S}\mathfrak{g}}} \hat{S}\mathfrak{g} \rightarrow \mathbb{K} \rightarrow 0$$

under the right-exact functor  $M \hat{\otimes} \_$  (see corollary A.13).  $\square$

*Proof that  $\tilde{\heartsuit}$  is full and faithful.* The above claim gives us for any  $X, Y \in \mathfrak{G}$  a commutative diagram

$$\begin{array}{ccc} \mathfrak{G}(X, Y) & \xrightarrow{\tilde{\heartsuit}} & \mathcal{A}(\tilde{\heartsuit} X, \tilde{\heartsuit} Y) \\ & \searrow = & \downarrow \clubsuit \\ & & \mathfrak{G}(X, Y) \end{array}$$

From that we see that  $\tilde{\heartsuit}$  is faithful. In order to see that it is full we show that the map  $\mathcal{A}(\tilde{\heartsuit} X, \tilde{\heartsuit} Y) \xrightarrow{\clubsuit} \mathfrak{G}(X, Y)$  in the above diagram is injective. To prove it, we take  $\phi \in \mathcal{A}(\tilde{\heartsuit} X, \tilde{\heartsuit} Y)$  s.t.  $\clubsuit \phi = 0$  in  $\mathfrak{G}(X, Y)$  and we want to show that then  $\phi$  itself must be 0, i.e. that

$$(\phi s)(\xi) = 0, \quad \text{for all } s \in \heartsuit X, \xi \in \mathcal{U}\mathfrak{p} .$$

And really

$$\begin{aligned} (\phi s)(\xi) &= (\xi \triangleright (\phi s))(1) = (\phi(\xi \triangleright s))(1) = \\ &= \pi_Y(\phi(\xi \triangleright s)) = (\clubsuit \phi)(\pi_X(\xi \triangleright s)) = 0 . \end{aligned}$$

Here the first equality comes from the definition of the action of  $\xi \in \mathcal{U}\mathfrak{p}$  on  $\heartsuit X$ , the second is  $\mathcal{U}\mathfrak{p}$ -linearity of  $\phi$ , the third is just the definition of  $\pi_Y$ , the fourth

comes from commutativity of<sup>12</sup>

$$\begin{array}{ccc} \tilde{\heartsuit}X & \xrightarrow{\pi_X} & X \\ \phi \downarrow & & \downarrow \clubsuit \phi \\ \tilde{\heartsuit}Y & \xrightarrow{\pi_Y} & Y \end{array}$$

and the last one from our assumption that  $\clubsuit \phi = 0$ .  $\square$

*Proof that  $\tilde{\heartsuit}M \cong M \hat{\otimes} A$  for  $M \in \text{ob}(\mathcal{P})$ .* Assume that an  $X \in \text{ob}(\mathcal{V}^{\text{cp1}})$  is equipped with commuting equicontinuous left actions of  $\mathfrak{g}$  and  $\mathfrak{p}$  at the same time. Then we can use the  $\mathfrak{g}$ -action to form the space  $\text{Hom}_{\mathcal{U}\mathfrak{g}}^{\mathcal{C}}(\mathcal{U}\mathfrak{p}, X)$  and the  $\mathfrak{p}$  action to turn it into a left  $\mathfrak{p}$ -module by formula

$$(z \triangleright f)(\cdot) := \sum z_{(1)} \triangleright (f(\cdot \cdot z_{(2)})), \quad \text{for } f \in \text{Hom}_{\mathcal{U}\mathfrak{g}}^{\mathcal{C}}(\mathcal{U}\mathfrak{p}, X); z \in \mathcal{U}\mathfrak{p}.$$

Note that  $\text{Hom}_{\mathcal{U}\mathfrak{g}}^{\mathcal{C}}(\mathcal{U}\mathfrak{p}, X)$  has also a natural right  $A$ -module structure, so we get  $\text{Hom}_{\mathcal{U}\mathfrak{g}}^{\mathcal{C}}(\mathcal{U}\mathfrak{p}, X) \in \text{ob}(\mathcal{A})$ .

An  $M \in \text{ob}(\mathcal{P})$  can be turned into a  $\mathfrak{g} \otimes \mathfrak{p}$ -module in two natural ways:

- a)  $\mathfrak{g}$ -action is the restriction of the original  $\mathfrak{p}$ -action and the new  $\mathfrak{p}$ -action is trivial;
- b)  $\mathfrak{g}$ -action is trivial and the  $\mathfrak{p}$ -action is the original one.

Denote these two bimodules by  $M_a$  and  $M_b$ . One can see<sup>13</sup> that

$$\tilde{\heartsuit}M = \text{Hom}_{\mathcal{U}\mathfrak{g}}^{\mathcal{C}}(\mathcal{U}\mathfrak{p}, M_a) \quad \text{and} \quad M \hat{\otimes} A \cong \text{Hom}_{\mathcal{U}\mathfrak{g}}^{\mathcal{C}}(\mathcal{U}\mathfrak{p}, M_b).$$

We want to show that these two objects are isomorphic in  $\mathcal{A}$ . Take a map

$$(8.4) \quad \begin{array}{c} \text{Hom}_{\mathcal{U}\mathfrak{g}}^{\mathcal{C}}(\mathcal{U}\mathfrak{p}, M_a) \longrightarrow \text{Hom}_{\mathcal{U}\mathfrak{g}}^{\mathcal{C}}(\mathcal{U}\mathfrak{p}, M_b) \\ s \longmapsto \left( \mathcal{U}\mathfrak{p} \xrightarrow{\Delta} \mathcal{U}\mathfrak{p} \otimes \mathcal{U}\mathfrak{p} \xrightarrow{S \otimes s} \mathcal{U}\mathfrak{p} \otimes M \xrightarrow{\triangleright} M \right) \end{array}$$

with an obvious inverse

$$\begin{array}{c} \text{Hom}_{\mathcal{U}\mathfrak{g}}^{\mathcal{C}}(\mathcal{U}\mathfrak{p}, M_b) \longrightarrow \text{Hom}_{\mathcal{U}\mathfrak{g}}^{\mathcal{C}}(\mathcal{U}\mathfrak{p}, M_a) \\ s \longmapsto \left( \mathcal{U}\mathfrak{p} \xrightarrow{\Delta} \mathcal{U}\mathfrak{p} \otimes \mathcal{U}\mathfrak{p} \xrightarrow{\text{id} \otimes s} \mathcal{U}\mathfrak{p} \otimes M \xrightarrow{\triangleright} M \right). \end{array}$$

One should check that

<sup>12</sup>From the proof of the claim one can see that  $\pi_X = \varepsilon_A \otimes_A \text{id}_X$ . Thus our square is just the commutative square

$$\begin{array}{ccc} A \otimes_A \tilde{\heartsuit}X & \xrightarrow{\varepsilon_A \otimes_A \text{id}_X} & \mathbb{K} \otimes_A \tilde{\heartsuit}X \\ \text{id}_A \otimes_A \phi \downarrow & & \downarrow \text{id}_{\mathbb{K}} \otimes_A \phi \\ A \otimes_A \tilde{\heartsuit}Y & \xrightarrow{\varepsilon_A \otimes_A \text{id}_Y} & \mathbb{K} \otimes_A \tilde{\heartsuit}Y \end{array}$$

<sup>13</sup>The first equality is just the definition of  $\tilde{\heartsuit}M$ . For the second, we have an  $\mathcal{A}$ -morphism  $M \hat{\otimes} A = M \hat{\otimes} \text{Hom}_{\mathcal{U}\mathfrak{g}}^{\mathcal{C}}(\mathcal{U}\mathfrak{p}, \mathbb{K}) \longrightarrow \text{Hom}_{\mathcal{U}\mathfrak{g}}^{\mathcal{C}}(\mathcal{U}\mathfrak{p}, M_b)$  and it is iso by the proposition 8.2.

- it transforms continuous  $\mathcal{U}\mathfrak{g}$ -linear maps  $\mathcal{U}\mathfrak{p} \rightarrow M_a$  into continuous  $\mathcal{U}\mathfrak{g}$ -linear maps  $\mathcal{U}\mathfrak{p} \rightarrow M_b$ ;
- it is  $\mathcal{U}\mathfrak{p}$ -linear and continuous w.r.t. the strong topologies;
- it is  $A$ -linear.

Linearities are straightforward though lengthy. We relegate the continuity to the appendix (claim D.7).  $\square$

*Proof of the part (3) of Theorem 8.5.* Let's denote by  $\Xi$  the isomorphism  $\Xi : \mathcal{A}(\tilde{\mathcal{V}}M, \tilde{\mathcal{V}}N) \xrightarrow{\cong} \mathcal{A}(M \hat{\otimes} A, N \hat{\otimes} A)$ . Our statement can be formulated as: for  $f \in \mathcal{G}(M, N)$  the composition

$$(8.5) \quad M \xrightarrow{\text{id} \hat{\otimes} 1_A} M \hat{\otimes} A \xrightarrow{\Xi \tilde{\mathcal{V}}f} N \hat{\otimes} A \xrightarrow{\text{id}_N \hat{\otimes} \varepsilon_A} N$$

is equal to  $f$ . In the diagram

$$\begin{array}{ccccc}
 & & \tilde{\mathcal{V}}N & \xrightarrow{\cong} & N \hat{\otimes} A \\
 & \tilde{\mathcal{V}}f \nearrow & & \searrow \Xi \tilde{\mathcal{V}}f & \\
 \tilde{\mathcal{V}}M & \xrightarrow{\cong} & M \hat{\otimes} A & \xrightarrow{\pi_N} & N \\
 & \searrow \pi_M & \swarrow \text{id}_N \hat{\otimes} \varepsilon_A & \nearrow f & \\
 & & M & & 
 \end{array}$$

$\tilde{\mathcal{V}}M \xrightarrow{\pi_M} M$

the upper rectangle commutes by definition of  $\Xi$ , the rear rectangle is the naturality of  $\pi_M$  and the two triangles are easily seen to commute. Thus we get the commutative square

$$\begin{array}{ccc}
 M \hat{\otimes} A & \xrightarrow{\Xi \tilde{\mathcal{V}}f} & N \hat{\otimes} A \\
 \text{id}_M \hat{\otimes} \varepsilon_A \downarrow & & \downarrow \text{id}_N \hat{\otimes} \varepsilon_A \\
 M & \xrightarrow{f} & N
 \end{array}$$

from which we see that the composition (8.5) is indeed equal to  $f$ .  $\square$

## 9. REPRESENTING $\mathcal{U}\mathfrak{g}$ AS ENDOMORPHISMS OF $\mathbf{h} : \mathcal{F} \rightarrow \mathcal{V}^{\text{cpl}}$

Let's introduce a new category  $\mathcal{G}'$  with  $\text{ob}(\mathcal{G}') := \text{ob}(\mathcal{P})$  and  $\mathcal{G}'(M, N) := \mathcal{G}(M, N)$  for  $M, N \in \text{ob}(\mathcal{G}')$ .

### 9.1. Categories $\mathcal{G}'$ and $\mathcal{F}$ are isomorphic.

**Theorem 9.1.** *We have an isomorphism of symmetric monoidal categories  $\tilde{\heartsuit} : \mathcal{G}' \xrightarrow{\cong} \mathcal{F}$  that makes the following diagram commutative:*

$$\begin{array}{ccc} & \mathcal{P} & \\ \text{forg} \swarrow & & \searrow \hat{\otimes} A \\ \mathcal{G}' & \xrightarrow[\tilde{\heartsuit}]{\cong} & \mathcal{F} \end{array}$$

The inverse  $\tilde{\heartsuit}^{-1}$  is given on objects as  $M \otimes A \mapsto M$  and on morphisms by Formula (8.1).

*Proof.* We have  $\text{ob}(\mathcal{G}') = \text{ob}(\mathcal{P}) = \text{ob}(\mathcal{F})$  so  $\tilde{\heartsuit}$  is the identity on objects. To define it on the morphisms, take  $M, N \in \text{ob}(\mathcal{P})$ . The theorem 8.5 gives us an isomorphism

$$\mathcal{G}'(M, N) = \mathcal{G}(M, N) \xrightarrow[\cong]{\tilde{\heartsuit}} \mathcal{A}(\tilde{\heartsuit} M, \tilde{\heartsuit} N) \cong \mathcal{F}(M \hat{\otimes} A, N \hat{\otimes} A).$$

□

**9.2. Coalgebra  $(Q, \iota_C \circ \pi_C)$  in  $\text{Split}(\mathcal{G}')$ .** We have a fully faithful, strong-monoidal functor  $\text{Split}(\mathcal{G}') \rightarrow \mathcal{G}$ . Our next goal is to see  $C = \mathcal{U}\mathfrak{g}$  as a coalgebra in  $\text{Split}(\mathcal{G}')$ .

Denote by  $Q := \heartsuit C \in \text{ob}(\mathcal{P})$ . We have a surjective  $\mathcal{G}$ -morphism  $\pi_C : Q \rightarrow C$  (see the subsection 8.4). Since  $C$  is a free one dimensional  $\mathcal{U}\mathfrak{g}$ -module (we take the base vector  $1 \in \mathcal{U}\mathfrak{g} = C$ ), we can define a right inverse  $\iota_C : C \rightarrow Q$  of  $\pi_C$  just by specifying any  $s_0 := \iota_C(1) \in Q = \text{Hom}_{\mathcal{U}\mathfrak{g}}^C(\mathcal{U}\mathfrak{p}, \mathcal{U}\mathfrak{g})$  that satisfies  $s_0(1_{\mathcal{U}\mathfrak{p}}) = 1_{\mathcal{U}\mathfrak{g}}$ . This way we get that  $C$  is isomorphic to  $(Q, \iota_C \circ \pi_C)$ .

The coalgebra structure  $\Delta : C \rightarrow C \otimes C$ ,  $\varepsilon : C \rightarrow \mathbb{K}$  on  $C$  gives us the following coalgebra structure on  $(Q, \iota_C \circ \pi_C)$ :

$$(9.1) \quad Q \xrightarrow{\pi_C} C \xrightarrow{\Delta} C \hat{\otimes} C \xrightarrow{\iota_C \hat{\otimes} \iota_C} Q \hat{\otimes} Q; \quad Q \xrightarrow{\pi_C} C \xrightarrow{\varepsilon} \mathbb{K}.$$

*Remark 9.2.* Note that the explicit isomorphism between the functor  $\mathbf{h}_{(Q, \iota_C \circ \pi_C)} : \mathcal{G}' \rightarrow \mathcal{V}^{\text{top}}$  represented by  $(Q, \iota_C \circ \pi_C)$  and  $\mathcal{G}' \xrightarrow{\text{forg}} \mathcal{V}^{\text{cpl}}$  is given for  $M \in \text{ob}(\mathcal{G}') = \text{ob}(\mathcal{P})$  as

$$\begin{aligned} \mathbf{h}_{(Q, \iota_C \circ \pi_C)}(M) &= \{f \in \mathcal{G}(Q, M) \mid f \circ (\iota_C \circ \pi_C) = f\} \xrightarrow{\cong} M \\ f &\mapsto f(s_0). \end{aligned}$$

**9.3. Our choice of  $s_0$ .** We choose a special  $s_0$  as follows. The restriction isomorphism (claim D.4) gives us

$$Q = \heartsuit C = \text{Hom}_{\mathcal{U}\mathfrak{g}}^C(\mathcal{U}\mathfrak{d}, \mathcal{U}\mathfrak{g}) = \text{Hom}_{\mathbb{K}}^C(S\mathfrak{g}^*, \mathcal{U}\mathfrak{g}).$$

So we prescribe  $s_0$  by taking  $s_0(1_{S\mathfrak{g}^*}) = 1_{\mathcal{U}\mathfrak{g}}$  and  $s_0|_{S^{>0}\mathfrak{g}^*} = 0$ .

*Remark 9.3.* We will use in the computations the following formulation of our definition of  $s_0$ :

$$\pi_C(s_0) = 1 \quad \text{and} \quad \pi_C(y \triangleright s_0) = 0 \quad \text{if } y \in S^k \mathfrak{g}^*, k > 0.$$

9.4. **Coalgebra**  $((Q \hat{\otimes} A, p), \Delta_Q, \varepsilon_Q)$  in  $\text{Split}(\mathcal{F})$ . We apply the isomorphism  $\tilde{\heartsuit}$  to  $(Q, \iota_C \circ \pi_C)$  in  $\text{Split}(\mathcal{G}')$  and get an object  $(Q \hat{\otimes} A, p)$  in  $\text{Split}(\mathcal{F})$  where  $p := \tilde{\heartsuit}(\iota_C \circ \pi_C)$ . Applying  $\tilde{\heartsuit}$  to (9.1) we get a coproduct and a counit on  $(Q \hat{\otimes} A, p)$  which we denote as  $\Delta_Q$  and  $\varepsilon_Q$ .

9.5. **Functor**  $\mathbf{h} : \mathcal{F} \rightarrow \mathcal{V}^{\text{cpl}}$ . Denote by  $\mathbf{h}$  the monoidal functor represented by the coalgebra  $(Q \hat{\otimes} A, p) \in \text{Split}(\mathcal{F})$ . It is a priori just a monoidal functor to  $\mathcal{V}^{\text{top}}$  but since it is isomorphic to the functor

$$\mathcal{F} \xrightarrow{\cong} \mathcal{G}' \xrightarrow{\text{forget}} \mathcal{V}^{\text{cpl}}$$

we see that  $\mathbf{h}$  is actually a strong monoidal functor to  $\mathcal{V}^{\text{cpl}}$ . One also sees that the bialgebra  $\text{End}(\mathbf{h})$  is isomorphic to  $\mathcal{U}\mathfrak{g}$ .

9.6. **Explicit formulas.** In the rest of this section we write down some pictorial formulas which will be used in the subsequent computations. First of all, the maps

$$\begin{aligned} p &\in \mathcal{F}(Q \hat{\otimes} A, Q \hat{\otimes} A) = \mathcal{P}(Q, Q \hat{\otimes} A) \\ \Delta_Q &\in \mathcal{F}(Q \hat{\otimes} A, (Q \hat{\otimes} A) \otimes_A (Q \hat{\otimes} A)) = \mathcal{P}(Q, Q \hat{\otimes} Q \hat{\otimes} A); \\ \varepsilon_Q &\in \mathcal{F}(Q \hat{\otimes} A, A) = \mathcal{P}(Q, A) \end{aligned}$$

are uniquely determined by (see the formula (8.1)):

$$(9.2) \quad \begin{array}{c} Q \\ \swarrow \quad \searrow \\ \bullet \quad \bullet \\ \downarrow \\ \boxed{p} \\ \downarrow \\ Q \end{array} = Q \xrightarrow{\pi_C} C \xrightarrow{\iota_C} Q$$

$$(9.3) \quad \begin{array}{c} Q \quad Q \\ \swarrow \quad \downarrow \quad \searrow \\ \bullet \quad \bullet \quad \bullet \\ \downarrow \\ \boxed{\Delta_Q} \\ \downarrow \\ Q \end{array} = Q \xrightarrow{\pi_C} C \xrightarrow{\Delta} C \hat{\otimes} C \xrightarrow{\iota_C \hat{\otimes} \iota_C} Q \hat{\otimes} Q$$

$$(9.4) \quad \begin{array}{c} \bullet \\ \downarrow \\ \boxed{\varepsilon_Q} \\ \downarrow \\ Q \end{array} = Q \xrightarrow{\pi_C} C \xrightarrow{\varepsilon} \mathbb{K}$$

*Remark 9.4.* Using the remark 9.2, the explicit isomorphism between  $\mathcal{P} \xrightarrow{\hat{\otimes} A} \mathcal{F} \xrightarrow{\mathbf{h}} \mathcal{V}^{\text{cpl}}$  and  $\mathcal{P} \xrightarrow{\text{forget}} \mathcal{V}^{\text{cpl}}$  is given for  $M \in \text{ob}(\mathcal{P})$  by

$$\mathbf{h}(M \hat{\otimes} A) = \left\{ \begin{array}{c} M \quad A \\ \swarrow \quad \searrow \\ \bullet \quad \bullet \\ \downarrow \\ \boxed{f} \\ \downarrow \\ Q \end{array} \in \mathcal{P}(Q, M \hat{\otimes} A) \mid \begin{array}{c} M \quad A \\ \swarrow \quad \searrow \\ \bullet \quad \bullet \\ \downarrow \\ \boxed{f} \\ \downarrow \\ \boxed{p} \\ \downarrow \\ Q \end{array} = f \right\} \rightarrow M : f \mapsto \begin{array}{c} M \\ \downarrow \\ \bullet \\ \downarrow \\ \boxed{f} \\ \downarrow \\ \circ \end{array}$$

where  $\begin{array}{c} Q \\ \downarrow \\ \circ \end{array}$  is the linear map  $\mathbb{K} \rightarrow Q : 1 \mapsto s_0$ .

**Notation 9.5.** For later use we denote by  $\hat{m} \in \mathbf{h}(M \hat{\otimes} A)$  the element corresponding to  $m \in M$  under this isomorphism. That is,  $\hat{m} \in \mathcal{P}(Q, M \hat{\otimes} A)$  is uniquely characterized by:

$$(9.5) \quad \begin{array}{c} M \\ \swarrow \quad \bullet \\ \boxed{\hat{m}} \\ \downarrow \\ Q \end{array} = Q \xrightarrow{\pi_C} C = \mathcal{U}\mathfrak{g} \xrightarrow{\triangleright m} M.$$

*Remark 9.6.*  $\Delta_Q$  and  $\varepsilon_Q$  are actually morphisms in  $\text{Split}(\mathcal{F})$ :

$$\Delta_Q : (Q \hat{\otimes} A, p) \rightarrow (Q \hat{\otimes} A, p) \otimes_A (Q \hat{\otimes} A, p), \quad \varepsilon_Q : (Q \hat{\otimes} A, p) \rightarrow A.$$

This translates into diagram equations:

$$(9.6) \quad \begin{array}{c} Q \quad Q \quad A \\ \swarrow \quad \downarrow \quad \searrow \\ \boxed{p} \quad \boxed{p} \\ \downarrow \quad \downarrow \\ \boxed{\Delta_Q} \\ \downarrow \\ \boxed{p} \\ \downarrow \\ Q \end{array} = \begin{array}{c} Q \quad Q \quad A \\ \swarrow \quad \downarrow \quad \searrow \\ \boxed{\Delta_Q} \\ \downarrow \\ Q \end{array} \quad \text{and} \quad \begin{array}{c} A \\ \swarrow \quad \searrow \\ \boxed{\varepsilon_Q} \\ \downarrow \\ \boxed{p} \\ \downarrow \\ Q \end{array} = \begin{array}{c} A \\ \downarrow \\ \boxed{\varepsilon_Q} \\ \downarrow \\ Q \end{array}.$$

Similarly, the fact that  $\varepsilon_Q$  is a counit for  $\Delta_Q$  looks in pictures as:

$$(9.7) \quad \begin{array}{c} Q \quad A \\ \swarrow \quad \searrow \\ \boxed{\varepsilon_Q} \\ \downarrow \\ \boxed{\Delta_Q} \\ \downarrow \\ Q \end{array} = \begin{array}{c} Q \quad A \\ \swarrow \quad \searrow \\ \boxed{\varepsilon_Q} \\ \downarrow \\ \boxed{\Delta_Q} \\ \downarrow \\ Q \end{array} = \begin{array}{c} Q \quad A \\ \swarrow \quad \searrow \\ \boxed{p} \\ \downarrow \\ Q \end{array}.$$

*Remark 9.7.* The explicit monoidal structure on  $\mathbf{h}$  is

$$\mathbf{h}(M \hat{\otimes} A) \hat{\otimes} \mathbf{h}(N \hat{\otimes} A) \rightarrow \mathbf{h}(M \hat{\otimes} N \hat{\otimes} A) \quad \mathbb{K} \rightarrow \mathbf{h}(\mathbb{K} \hat{\otimes} A)$$

$$\begin{array}{c} M \quad A \\ \swarrow \quad \searrow \\ \boxed{f} \\ \downarrow \\ Q \end{array} \otimes \begin{array}{c} N \quad A \\ \swarrow \quad \searrow \\ \boxed{g} \\ \downarrow \\ Q \end{array} \mapsto \begin{array}{c} M \quad M \quad A \\ \swarrow \quad \downarrow \quad \searrow \\ \boxed{f} \quad \boxed{g} \\ \downarrow \quad \downarrow \\ \boxed{\Delta_Q} \\ \downarrow \\ Q \end{array} \quad 1 \mapsto \begin{array}{c} A \\ \downarrow \\ \boxed{\varepsilon_Q} \\ \downarrow \\ Q \end{array}$$

## 10. PASSING FROM $\mathbb{K}$ TO $\mathbb{K}[[\hbar]]$

To get a similar representation for  $\mathcal{U}\mathfrak{g}[[\hbar]]$ , we simply apply to our categories the construction  $\mathcal{C} \mapsto \mathcal{C}[[\hbar]]$  described in the subsection E.1. We denote the categories important for us as follows:

$$\mathcal{P}_{\hbar} := \mathcal{P}[[\hbar]]; \quad \mathcal{F}_{\hbar} := \left( \mathbf{Free}\text{-}A(\mathcal{P}) \right)[[\hbar]] = \mathbf{Free}\text{-}A(\mathcal{P}_{\hbar}).$$

In  $\mathcal{F}_{\hbar}$  we still have our  $Q$  and  $p : Q \rightarrow Q$  and can form the functor  $\mathbf{h}_{(Q \hat{\otimes} A, p)}$  represented by  $(Q, p)$ . A priori it will be a functor to  $\mathcal{V}_{\mathbb{K}[[\hbar]]}^{\hbar\text{-cp1}}$ , but according to

Proposition E.6 it actually takes values in  $\mathcal{V}_{\mathbb{K}[[\hbar]]}^{\text{cpl}}$ . This way,  $\mathbf{h}_{(Q \hat{\otimes} A, \mathfrak{p})} : \mathcal{F}_{\hbar} \rightarrow \mathcal{V}_{\mathbb{K}[[\hbar]]}^{\text{cpl}}$  becomes a strong-monoidal functor (it is just monoidal as a functor to  $\mathcal{V}_{\mathbb{K}[[\hbar]]}^{\hbar\text{-cpl}}$ ) and we get an isomorphism of bialgebras  $\mathcal{U}\mathfrak{g}[[\hbar]] \cong \text{End} \left( \mathbf{h}_{(Q \hat{\otimes} A, \mathfrak{p})} : \mathcal{F}_{\hbar} \rightarrow \mathcal{V}_{\mathbb{K}[[\hbar]]}^{\text{cpl}} \right)$ .

**Notation 10.1.** We define the forgetful functor  $\mathcal{P}_{\hbar} \xrightarrow{\text{forg}} \mathcal{V}_{\mathbb{K}[[\hbar]]}^{\text{cpl}}$  on objects by

$$M \in \text{ob}(\mathcal{P}_{\hbar}) = \text{ob}(\mathcal{P}) \mapsto (\mathbf{F}_{\mathcal{V}^{\text{cpl}}}^{\mathfrak{p}}(M))[[\hbar]]$$

and on morphisms in a natural way.

## 11. APPLYING AN ASSOCIATOR

**11.1. Drinfeld associator.** Denote by  $\mathbb{K}\langle\langle X, Y \rangle\rangle$  the degree-wise completed free algebra generated by non-commuting elements  $X, Y$ . Recall that an associator  $\Phi$  is a group-like<sup>14</sup> element  $\Phi(X, Y) \in \mathbb{K}\langle\langle X, Y \rangle\rangle$  satisfying some properties (pentagon and hexagon relations) that ensure (and are equivalent to) that if we take a Lie algebra  $\mathfrak{p}$  with an invariant  $t \in S^2\mathfrak{p}$  then  $\mathcal{U}\mathfrak{p}[[\hbar]]$  with the ordinary algebra structure, coproduct and counit but with<sup>15</sup>

$$(11.1) \quad R_{\mathfrak{p}} := \exp\left(\frac{\hbar t}{2}\right); \quad \Phi_{\mathfrak{p}} := \Phi(\hbar t_{12}, \hbar t_{23})$$

becomes a quasi-triangular quasi-bialgebra that we denote as  $\mathcal{U}_{\hbar}\mathfrak{p}$ .

*Remark 11.1.* One can show that  $\Phi(X, Y)$  is of the form  $\Phi(X, Y) = 1 +$  terms of order at least 2 in  $X, Y$ .

We define a new braided monoidal category  $\mathcal{P}_{\hbar}^{\Phi}$  as being the same category as  $\mathcal{P}_{\hbar}$ , with the same bifunctor  $\hat{\otimes} : \mathcal{P}_{\hbar}^{\Phi} \times \mathcal{P}_{\hbar}^{\Phi} \rightarrow \mathcal{P}_{\hbar}^{\Phi}$  and the same identity object but with the braiding and associativity isomorphisms defined as<sup>16</sup>

$$\begin{aligned} \beta : M \hat{\otimes} N &\xrightarrow{R_{\mathfrak{p}} \triangleright} M \hat{\otimes} N \xrightarrow{\text{symmetry in } \mathcal{P}_{\hbar}} N \hat{\otimes} M \\ \phi : (K \hat{\otimes} L) \hat{\otimes} M &\xrightarrow{\Phi_{\mathfrak{p}} \triangleright} (K \hat{\otimes} L) \hat{\otimes} M \xrightarrow{\text{assoc. in } \mathcal{P}_{\hbar}} K \hat{\otimes} (L \hat{\otimes} M). \end{aligned}$$

*Remark 11.2.* The identity functor  $\mathcal{P}_{\hbar}^{\Phi} \xrightarrow{\cong} \mathcal{P}_{\hbar}$  is strong quasi-monoidal so the composition

$$\text{forg} : \mathcal{P}_{\hbar}^{\Phi} \xrightarrow{\cong} \mathcal{P}_{\hbar} \xrightarrow{\text{forg}} \mathcal{V}_{\mathbb{K}[[\hbar]]}^{\text{cpl}}$$

also is. The quasi-bialgebra  $\text{End}(\mathcal{P}_{\hbar}^{\Phi} \xrightarrow{\text{forg}} \mathcal{V}_{\mathbb{K}[[\hbar]]}^{\text{cpl}})$  is isomorphic to  $\mathcal{U}_{\hbar}\mathfrak{p}$  defined above. Note also that the classical limit of the quasi-bialgebra  $\mathcal{U}_{\hbar}\mathfrak{p}$  is the quasi-Lie bialgebra associated to the pair  $(\mathfrak{p}, t)$  (see Definition 4.4).

<sup>14</sup>The coproduct is determined by  $X, Y$  being primitive.

<sup>15</sup>Here  $t_{1,2} := 1 \otimes t$  and  $t_{2,3} := t \otimes 1$  are elements of  $\mathcal{U}\mathfrak{p} \hat{\otimes} \mathcal{U}\mathfrak{p} \hat{\otimes} \mathcal{U}\mathfrak{p}$ .

<sup>16</sup>Technically speaking, objects in  $\text{ob}(\mathcal{P}_{\hbar}) = \text{ob}(\mathcal{P})$  are just  $\mathfrak{p}$ -modules over  $\mathbb{K}$  and thus the multiplication by  $R_{\mathfrak{p}}$  does not make sense. However, the multiplication by  $t$  is a well defined morphism  $M \hat{\otimes} N \xrightarrow{t \triangleright} M \hat{\otimes} N$  in  $\mathcal{P}$  and thus we can define the  $\mathcal{P}_{\hbar}$ -morphism  $M \hat{\otimes} N \xrightarrow{R_{\mathfrak{p}} \triangleright} M \hat{\otimes} N$  as  $\exp\left(\frac{\hbar}{2} \cdot (t \triangleright -)\right)$ . Multiplication by  $\Phi_{\mathfrak{p}}$  is defined in the same way.

### 11.2. Category $\mathcal{F}_\hbar^\Phi$ .

**Proposition 11.3.** *The algebra  $A$  stays a commutative associative algebra also in  $\mathcal{P}_\hbar^\Phi$  (with the same multiplication).*

*Proof.* Since both  $R_p, \Phi_p$  are sums of the form  $1+$  terms of order at least one in  $\hbar t$ , we just need to show that the  $\mathcal{P}$ -morphism  $A \hat{\otimes} A \xrightarrow{t\triangleright} A \hat{\otimes} A \xrightarrow{\mu_A} A$  is 0. From the last part of the theorem 8.5 we see that this is equivalent to showing

$$(A \hat{\otimes} A \xrightarrow{t\triangleright} A \hat{\otimes} A \xrightarrow{\mu_A} A \xrightarrow{\varepsilon_A} \mathbb{K}) = 0.$$

Since  $\varepsilon_A$  is an augmentation on  $A$  in  $\mathcal{G}$ , we rewrite the left had side as

$$(11.2) \quad A \hat{\otimes} A \xrightarrow{t\triangleright} A \hat{\otimes} A \xrightarrow{\varepsilon_A \hat{\otimes} \varepsilon_A} \mathbb{K}.$$

Now  $t \in (\mathfrak{g} \hat{\otimes} \mathfrak{g}^*) + (\mathfrak{g}^* \hat{\otimes} \mathfrak{g})$  and from  $\mathfrak{g}$ -linearity of  $\varepsilon_A \in \mathcal{G}(A, \mathbb{K})$  we see that

$$\varepsilon_A \circ (x \triangleright \lrcorner) = (x \triangleright \lrcorner) \circ \varepsilon_A = 0 \quad \forall x \in \mathfrak{g}$$

and thus the composition (11.2) is 0.  $\square$

We denote  $\mathcal{F}_\hbar^\Phi := \mathbf{Free}\text{-}A(\mathcal{P}_\hbar^\Phi)$ .

### 11.3. Bijection $\mathcal{F}_\hbar \rightarrow \mathcal{F}_\hbar^\Phi$ .

Our definitions give us

$$\text{ob}(\mathcal{F}_\hbar) = \text{ob}(\mathcal{P}_\hbar) = \text{ob}(\mathcal{P}_\hbar^\Phi) = \text{ob}(\mathcal{F}_\hbar^\Phi)$$

$$\mathcal{F}_\hbar(X \hat{\otimes} A, Y \hat{\otimes} A) = \mathcal{P}_\hbar(X, Y \hat{\otimes} A) = \mathcal{P}_\hbar^\Phi(X, Y \hat{\otimes} A) = \mathcal{F}_\hbar^\Phi(X \hat{\otimes} A, Y \hat{\otimes} A) \quad X, Y \in \text{ob}(\mathcal{P}_\hbar).$$

Note that the formula (6.1) defining the composition in  $\mathcal{F}_\hbar$  and  $\mathcal{F}_\hbar^\Phi$  depends on the associativity isomorphisms and thus the identity map  $\mathcal{F}_\hbar \rightarrow \mathcal{F}_\hbar^\Phi$  is not a functor. Similarly, although it respects the tensor product on objects, it does not preserve the tensor product of morphism since the expression (6.2) involves the braiding and associativity isomorphisms in the underlying categories.

At least however, the associativity isomorphisms in  $\mathcal{P}_\hbar$  and  $\mathcal{P}_\hbar^\Phi$  are equal modulo  $\hbar^2$  and the braidings are equal modulo  $\hbar$ , so the compositions of morphisms in  $\mathcal{F}_\hbar$  and  $\mathcal{F}_\hbar^\Phi$  are the same modulo  $\hbar^2$  and the tensor products of morphisms are the same modulo  $\hbar$ .

Next we want to extend this construction to a map  $\text{Split}(\mathcal{F}_\hbar) \rightarrow \text{Split}(\mathcal{F}_\hbar^\Phi)$ .

**11.4. Map  $\text{Split}(\mathcal{F}_\hbar) \rightarrow \text{Split}(\mathcal{F}_\hbar^\Phi)$  on objects.** Given  $(X \hat{\otimes} A, p) \in \text{ob}(\text{Split}(\mathcal{F}_\hbar))$  we can consider  $X \hat{\otimes} A$  as an object in  $\mathcal{F}_\hbar^\Phi$  and  $p$  as a morphism  $p : X \hat{\otimes} A \rightarrow X \hat{\otimes} A$  in  $\mathcal{F}_\hbar^\Phi$  but we can't be sure whether  $p^2 = p$  holds also in  $\mathcal{F}_\hbar^\Phi$ . We know however that it holds modulo  $\hbar$  and can use the following lemma to tweak our  $p$  a bit.

**Lemma 11.4.** *Let  $B$  be an algebra over  $\mathbb{K}[[\hbar]]$ , complete w.r.t. the  $\hbar$ -adic topology. Let  $p \in B$  satisfies  $p^2 \equiv p \pmod{\hbar}$ . Then there exists an element  $p' \in B$  s.t.*

$$p'^2 = p' \quad \text{and} \quad p' \equiv p \pmod{\hbar}.$$

*More concretely, there exist coefficients  $\alpha_1, \alpha_2, \dots \in \mathbb{Q}$  independent of  $B$  and  $p$  s.t.*

$$p' = p + \left(p - \frac{1}{2}\right) \cdot \left[\alpha_1(p^2 - p) + \alpha_2(p^2 - p)^2 + \dots\right]$$

*Proof.* Denote  $a := 2p - 1$ ,  $a' := 2p' - 1$ . Then  $a^2 - 1 = 4(p^2 - p)$  and so

$$\left(p^2 \equiv p \pmod{\hbar}\right) \iff \left(a^2 \equiv 1 \pmod{\hbar}\right) \quad \text{and} \quad \left(p'^2 = p'\right) \iff \left(a'^2 = 1\right).$$

Given  $a$  satisfying  $a^2 \equiv 1 \pmod{\hbar}$ , we can find  $a'$ ,  $\hbar$ -close to it from the formula

$$a' := \frac{a}{\sqrt{a^2}} = a \cdot (1 + (a^2 - 1))^{-\frac{1}{2}} = a \cdot (1 + \beta_1(a^2 - 1) + \beta_2(a^2 - 1)^2 + \dots)$$

where  $\beta_1, \beta_2, \dots \in \mathbb{Q}$  are the coefficients of the Taylor expansion of  $(1 + x)^{-\frac{1}{2}}$  at  $x = 0$ . So we can express  $p'$  out of it as

$$\begin{aligned} p' &= \frac{1}{2}(1 + a') = \frac{1}{2} \left[ (1 + a) + a \cdot (\beta_1(a^2 - 1) + \beta_2(a^2 - 1)^2 + \dots) \right] = \\ &= p + (p - \frac{1}{2}) \left( \frac{\beta_1}{2}(p^2 - p) + \frac{\beta_2}{2}(p^2 - p)^2 + \dots \right). \end{aligned}$$

□

In our case  $B = \mathcal{F}_\hbar^\Phi(X \hat{\otimes} A, X \hat{\otimes} A)$  and we denote  $p'$  from the lemma by  $p^\Phi$ . This way, we get a  $(Q \hat{\otimes} A, p^\Phi)$  in  $\mathcal{F}_\hbar^\Phi$ .

**11.5. Map  $\text{Split}(\mathcal{F}_\hbar) \rightarrow \text{Split}(\mathcal{F}_\hbar^\Phi)$  on morphisms.** Given  $(X \hat{\otimes} A, p), (Y \hat{\otimes} A, q) \in \text{ob}(\text{Split}(\mathcal{F}_\hbar))$  we define a linear map

$$\begin{aligned} \text{Split}(\mathcal{F}_\hbar) \left( (X \hat{\otimes} A, p), (Y \hat{\otimes} A, q) \right) &\rightarrow \text{Split}(\mathcal{F}_\hbar^\Phi) \left( (X \hat{\otimes} A, p^\Phi), (Y \hat{\otimes} A, q^\Phi) \right) : \\ f &\mapsto q^\Phi \circ f \circ p^\Phi \quad (\text{composition in } \mathcal{F}_\hbar^\Phi). \end{aligned}$$

*Remark 11.5.* This is actually a topological isomorphism since we can define a map in the opposite direction  $f \mapsto q \circ f \circ p$  (compositions in  $\mathcal{F}_\hbar$ ) and then use the following lemma:

**Lemma 11.6.** *Let  $V \in \text{ob}(\mathcal{V}_{\mathbb{K}[[\hbar]]}^{\hbar\text{-cpl}})$  (i.e.  $V$  is  $\hbar$ -complete) and let's have  $\Pi_1, \Pi_2 \in \mathcal{V}_{\mathbb{K}[[\hbar]]}^{\hbar\text{-cpl}}(V, V)$  satisfying  $\Pi_1^2 = \Pi_1$ ,  $\Pi_2^2 = \Pi_2$  and  $\Pi_1 \equiv \Pi_2 \pmod{\hbar}$ . Then  $\Pi_2|_{\text{Im}(\Pi_1)} : \text{Im}(\Pi_1) \rightarrow \text{Im}(\Pi_2)$  defines an isomorphism (in  $\mathcal{V}_{\mathbb{K}[[\hbar]]}^{\hbar\text{-cpl}}$ ) between  $\text{Im}(\Pi_1)$  and  $\text{Im}(\Pi_2)$ .*

*Proof.* Denote  $X_i := \text{Im}(\Pi_i)$ . We have two maps:

$$\Pi_2|_{X_1} : X_1 \rightarrow X_2 \quad \text{and} \quad \Pi_1|_{X_2} : X_2 \rightarrow X_1.$$

To see that they are isomorphisms we show that  $\Pi_1 \circ \Pi_2|_{X_1} : X_1 \rightarrow X_1$  and symmetrically  $\Pi_2 \circ \Pi_1|_{X_2} : X_2 \rightarrow X_2$  are isomorphisms. We want to define the inverse of  $\Pi_1 \circ \Pi_2|_{X_1}$  as  $\sum_n \xi^n$  where

$$\xi := \text{id}_{X_1} - \Pi_1 \circ \Pi_2|_{X_1} = (\Pi_1 \circ \Pi_1 - \Pi_1 \circ \Pi_2)|_{X_1} = \Pi_1 \circ (\Pi_1 - \Pi_2)|_{X_1}.$$

One needs to check that this sum converges to a continuous map. From the last expression one sees that  $\text{Im } \xi \subset \hbar V$  and consequently  $\text{Im } \xi^k \subset \hbar^k V$ . Thus  $\xi^k \rightarrow 0$  uniformly in the  $\hbar$ -topology. Since  $X_1$  is  $\hbar$ -complete (it is a direct summand of a  $\hbar$ -complete space) we see that our sum converges uniformly in the  $\hbar$ -topology. From the claim E.4 we see that our sum actually converges uniformly also w.r.t. the ordinary topology on  $V$ . This implies that its limit is continuous. □

**11.6. Functor  $\mathbf{h}^\Phi : \mathcal{F}_\hbar^\Phi \rightarrow \mathcal{V}_{\mathbb{K}[[\hbar]]}^{\text{cpl}}$ .** Recall that in the section 9 we defined an object  $(Q \hat{\otimes} A, p)$  in  $\text{Split}(\mathcal{F}_\hbar)$  and denoted the functor represented by it as  $\mathcal{F}_\hbar \xrightarrow{\mathbf{h}} \mathcal{V}_{\mathbb{K}[[\hbar]]}^{\text{cpl}}$ . Now we have  $(Q \hat{\otimes} A, p^\Phi)$  in  $\text{Split}(\mathcal{F}_\hbar^\Phi)$  and denote the represented functor  $\mathcal{F}_\hbar^\Phi \xrightarrow{\mathbf{h}^\Phi} \mathcal{V}_{\mathbb{K}[[\hbar]]}^{\text{cpl}}$ .

Note that the functors  $(\mathcal{P}_\hbar \xrightarrow{-\hat{\otimes} A} \mathcal{F}_\hbar \xrightarrow{\mathbf{h}} \mathcal{V}_{\mathbb{K}[[\hbar]]}^{\text{cpl}})$  and  $(\mathcal{P}_\hbar = \mathcal{P}_\hbar^\Phi \xrightarrow{-\hat{\otimes} A} \mathcal{F}_\hbar^\Phi \xrightarrow{\mathbf{h}^\Phi} \mathcal{V}_{\mathbb{K}[[\hbar]]}^{\text{cpl}})$  are naturally isomorphic. Explicitly,  $\mathbf{h}(M \hat{\otimes} A) = \text{Split}(\mathcal{F}_\hbar)((Q \hat{\otimes} A, p), M \hat{\otimes} A)$ ,  $\mathbf{h}^\Phi(M \hat{\otimes} A) = \text{Split}(\mathcal{F}_\hbar^\Phi)((Q \hat{\otimes} A, p^\Phi), M \hat{\otimes} A)$  and the isomorphism is  $f \mapsto f \circ_{\mathcal{F}_\hbar} p^\Phi$  from the subsection 11.5.

Now we have three functors  $\mathcal{P}_\hbar \rightarrow \mathcal{V}_{\mathbb{K}[[\hbar]]}^{\text{cpl}}$  and natural isomorphisms between them:<sup>17</sup>

$$\begin{array}{ccc}
 \mathcal{P}_\hbar & \xleftarrow{\cong} & \mathcal{P}_\hbar^\Phi \\
 \downarrow \text{ } \hat{\otimes} A & & \downarrow \text{ } \hat{\otimes} A \\
 \mathcal{F}_\hbar & \xrightarrow{\cong} & \mathcal{F}_\hbar^\Phi \\
 \downarrow \mathbf{h} & \swarrow \mathbf{h}^\Phi & \\
 \mathcal{V}_{\mathbb{K}[[\hbar]]}^{\text{cpl}} & & 
 \end{array}$$

forg

**Notation 11.7.** We denote by  $\hat{m} \in \mathbf{h}(M \hat{\otimes} A)$  and  $\hat{m}^\Phi \in \mathbf{h}^\Phi(M \hat{\otimes} A)$  the elements corresponding under these natural isomorphisms to  $m \in M[[\hbar]]$  for  $M \in \text{ob}(\mathcal{P}_\hbar)$ . The explicit isomorphism  $\hat{m} \mapsto \hat{m}^\Phi$  is given by the formula  $\hat{m}^\Phi = \hat{m} \circ_{\mathcal{F}_\hbar} p^\Phi$  i.e.

$$\begin{array}{c}
 \begin{array}{c} M \quad A \\ \diagdown \quad \diagup \\ \square_{\hat{m}^\Phi} \\ | \\ Q \end{array} = \begin{array}{c} M \quad A \\ \diagdown \quad \diagup \\ \square_{\hat{m}} \\ \diagdown \quad \diagup \\ \square_{p^\Phi} \\ | \\ Q \end{array} \quad (\text{diagram in } \mathcal{P}_\hbar^\Phi).
 \end{array}$$

**11.7. Bijection  $\mathcal{Ug}[[\hbar]] \xrightarrow{\cong} \text{End}(\mathcal{F}_\hbar^\Phi \xrightarrow{\mathbf{h}^\Phi} \mathcal{V}_{\mathbb{K}[[\hbar]]}^{\text{cpl}})$ .** Recall that we have a bialgebra isomorphism

$$\mathcal{Ug}[[\hbar]] \cong \text{End}_{\text{Split}(\mathcal{F}_\hbar)}((Q \hat{\otimes} A, p)) = \text{End}(\mathcal{F}_\hbar \xrightarrow{\mathbf{h}} \mathcal{V}_{\mathbb{K}[[\hbar]]}^{\text{cpl}}).$$

The subsection 11.5 gives us an isomorphism of topological  $\mathbb{K}[[\hbar]]$ -modules

$$\text{End}_{\text{Split}(\mathcal{F}_\hbar)}((Q \hat{\otimes} A, p)) \cong \text{End}_{\text{Split}(\mathcal{F}_\hbar^\Phi)}((Q \hat{\otimes} A, p^\Phi)) = \text{End}(\mathcal{F}_\hbar^\Phi \xrightarrow{\mathbf{h}^\Phi} \mathcal{V}_{\mathbb{K}[[\hbar]]}^{\text{cpl}})$$

Composing, we get an isomorphism of topological  $\mathbb{K}[[\hbar]]$ -modules

$$\mathcal{Ug}[[\hbar]] \xrightarrow{\cong} \text{End}(\mathcal{F}_\hbar^\Phi \xrightarrow{\mathbf{h}^\Phi} \mathcal{V}_{\mathbb{K}[[\hbar]]}^{\text{cpl}})$$

<sup>17</sup>Note that all the functors in the diagram are strong monoidal with exception of  $\mathbf{h}^\Phi$  and  $\mathcal{P}_\hbar \leftrightarrow \mathcal{P}_\hbar^\Phi$  which are strong quasi-monoidal (we will soon define the quasi-monoidal structure on  $\mathbf{h}^\Phi$ ). The natural equivalence in the left window is monoidal, the other is not.

**Lemma 11.8.** *The composition of  $\mathbb{K}[[\hbar]]$ -module morphisms*

$$\begin{aligned} \mathcal{Ug}[[\hbar]] &\xrightarrow{\cong} \text{End}(\mathcal{F}_\hbar^\Phi \xrightarrow{\mathbf{h}^\Phi} \mathcal{V}_{\mathbb{K}[[\hbar]]}^{\text{cpl}}) \rightarrow \\ &\rightarrow \text{End}(\mathcal{P}_\hbar^\Phi \xrightarrow{\hat{\otimes} A} \mathcal{F}_\hbar^\Phi \xrightarrow{\mathbf{h}^\Phi} \mathcal{V}_{\mathbb{K}[[\hbar]]}^{\text{cpl}}) \xrightarrow{\cong} \text{End}(\mathcal{P} \xrightarrow{\text{forg}} \mathcal{V}_{\mathbb{K}[[\hbar]]}^{\text{cpl}}) = \mathcal{Up}[[\hbar]] \end{aligned}$$

is modulo  $\hbar$  equal to the ordinary inclusion  $\mathcal{Ug}[[\hbar]] \hookrightarrow \mathcal{Up}[[\hbar]]$ .

**11.8. Quasi-monoidal structure on  $\mathbf{h}^\Phi$ .** Following the subsection 7.2, we want to find a quasi-coalgebra structure on  $(Q \hat{\otimes} A, p^\Phi)$ . The first try is to define

$$(11.3) \quad \Delta'_Q := (p^\Phi \otimes_{\mathcal{F}_\hbar^\Phi} p^\Phi) \circ_{\mathcal{F}_\hbar^\Phi} \Delta_Q \circ_{\mathcal{F}_\hbar^\Phi} p^\Phi; \quad \varepsilon'_Q := \varepsilon_Q \circ_{\mathcal{F}_\hbar^\Phi} p^\Phi.$$

We will see that  $\varepsilon'_Q = \varepsilon_Q$  in the lemma 11.10. First we need

**Claim 11.9.** *Let  $a \in \mathcal{F}_\hbar(X \hat{\otimes} A, A)$  and  $f \in \mathcal{F}_\hbar(Y \hat{\otimes} A, X \hat{\otimes} A)$  for some  $X, Y \in \mathcal{P}_\hbar$ . Then*

- (1)  $a \circ_{\mathcal{F}_\hbar^\Phi} f = a \circ_{\mathcal{F}_\hbar} f$
- (2)  $a \otimes_{\mathcal{F}_\hbar^\Phi} a = a \otimes_{\mathcal{F}_\hbar} a$

*Proof.* The two expressions

The left diagram shows a box labeled 'a' with a box labeled 'f' below it, both connected to a box labeled 'A' above. The right diagram shows a box labeled 'a' with two boxes labeled 'X' below it, both connected to a box labeled 'A' above.

contain neither the associativity isomorphism nor the braiding so they mean the same in  $\mathcal{P}_\hbar$  and in  $\mathcal{P}_\hbar^\Phi$ .  $\square$

**Lemma 11.10.**  $\varepsilon_Q \circ_{\mathcal{F}_\hbar^\Phi} p^\Phi = \varepsilon_Q$

*Proof.* By our definition (see the subsection 11.4),  $p^\Phi$  can be expressed as

$$p^\Phi = p + (p \circ_{\mathcal{F}_\hbar^\Phi} p - p) \circ_{\mathcal{F}_\hbar^\Phi} \text{something}.$$

We know that  $\varepsilon_Q \circ_{\mathcal{F}_\hbar} p = \varepsilon_Q$  and thus also (claim 11.9)  $\varepsilon_Q \circ_{\mathcal{F}_\hbar^\Phi} p = \varepsilon_Q$ . So we just need to show that  $\varepsilon_Q \circ_{\mathcal{F}_\hbar^\Phi} (p \circ_{\mathcal{F}_\hbar^\Phi} p - p) = 0$  what is now easy.  $\square$

The reason to write the formulas (11.3) is that it forces  $\Delta'_Q$  and  $\varepsilon'_Q$  to become maps between direct summands in  $\mathcal{F}_\hbar^\Phi$

$$\Delta'_Q : (Q \hat{\otimes} A, p^\Phi) \rightarrow (Q \hat{\otimes} A, p^\Phi) \otimes_A (Q \hat{\otimes} A, p^\Phi), \quad \varepsilon'_Q : (Q \hat{\otimes} A, p^\Phi) \rightarrow A.$$

It is however not clear whether  $\varepsilon'_Q = \varepsilon_Q$  will be a counit for  $\Delta'_Q$ , i.e. whether<sup>18</sup>

$$(\varepsilon_Q \otimes_{\mathcal{F}_\hbar^\Phi} \text{id}_{(Q \hat{\otimes} A)}) \circ_{\mathcal{F}_\hbar^\Phi} \Delta'_Q = (\text{id}_{(Q \hat{\otimes} A)} \otimes_{\mathcal{F}_\hbar^\Phi} \varepsilon_Q) \circ_{\mathcal{F}_\hbar^\Phi} \Delta'_Q = p^\Phi.$$

**Lemma 11.11.** *Let's have  $C \xrightarrow{\Delta} C \otimes C$ ;  $C \xrightarrow{\varepsilon} I$  (in some monoidal category  $\mathcal{C}$ ) satisfying that the composition  $C \xrightarrow{\Delta} C \otimes C \xrightarrow{\varepsilon \otimes \varepsilon} I$  equals  $\varepsilon$  and that the maps*

$$r : C \xrightarrow{\Delta} C \otimes C \xrightarrow{\varepsilon \otimes \text{id}} C \quad ; \quad s : C \xrightarrow{\Delta} C \otimes C \xrightarrow{\text{id} \otimes \varepsilon} C$$

are invertible.

<sup>18</sup>If  $(X, p)$  is a direct summand then  $\text{id}_{(X, p)} = p$ .

Then  $\bar{\Delta} : C \xrightarrow{\Delta} C \otimes C \xrightarrow{r^{-1} \otimes s^{-1}} C \otimes C$  and  $\bar{\varepsilon} := \varepsilon$  form a quasi-coalgebra structure on  $C$ .

*Proof.* First note that we have  $\varepsilon \circ r = (\varepsilon \otimes \varepsilon) \circ \Delta = \varepsilon$  and thus  $\varepsilon \circ r^{-1} = \varepsilon$ . Using this we can calculate:

$$\begin{aligned} (\bar{\varepsilon} \otimes \text{id}) \circ \bar{\Delta} &= (\varepsilon \otimes \text{id}) \circ (r^{-1} \otimes s^{-1}) \circ \Delta = \left( (\varepsilon \circ r^{-1}) \otimes s^{-1} \right) \circ \Delta = \\ &= s^{-1} \circ (\varepsilon \otimes \text{id}) \circ \Delta = s^{-1} \circ s = \text{id}_C. \end{aligned}$$

□

In order to use this lemma for our would-be quasi-coalgebra  $((Q \hat{\otimes} A, p^\Phi), \Delta'_Q, \varepsilon'_Q)$  in  $\text{Split}(\mathcal{F}_\hbar^\Phi)$ , we need to check

$$(11.4) \quad (\varepsilon_Q \otimes_{\mathcal{F}_\hbar^\Phi} \varepsilon_Q) \circ_{\mathcal{F}_\hbar^\Phi} \Delta'_Q = \varepsilon_Q$$

and verify that

$$(11.5) \quad r := (\varepsilon_Q \otimes_{\mathcal{F}_\hbar^\Phi} \text{id}_{(Q \hat{\otimes} A)}) \circ_{\mathcal{F}_\hbar^\Phi} \Delta'_Q; \quad s := (\text{id}_{(Q \hat{\otimes} A)} \otimes_{\mathcal{F}_\hbar^\Phi} \varepsilon_Q) \circ_{\mathcal{F}_\hbar^\Phi} \Delta'_Q$$

are invertible as maps  $(Q \hat{\otimes} A, p^\Phi) \rightarrow (Q \hat{\otimes} A, p^\Phi)$  in the category  $\text{Split}(\mathcal{F}_\hbar^\Phi)$ . The invertibility is easy, since<sup>19</sup>

$$r \equiv p \equiv p^\Phi \pmod{\hbar} \quad \text{and} \quad s \equiv p \equiv p^\Phi \pmod{\hbar}$$

and so we can define the inverses by the usual series.

*Proof of (11.4).* Just use the claim 11.9 and the lemma 11.10 repeatedly:

$$\begin{aligned} (\varepsilon_Q \otimes_{\mathcal{F}_\hbar^\Phi} \varepsilon_Q) \circ_{\mathcal{F}_\hbar^\Phi} \Delta'_Q &= (\varepsilon_Q \otimes_{\mathcal{F}_\hbar^\Phi} \varepsilon_Q) \circ_{\mathcal{F}_\hbar^\Phi} (p^\Phi \otimes_{\mathcal{F}_\hbar^\Phi} p^\Phi) \circ_{\mathcal{F}_\hbar^\Phi} \Delta_Q \circ_{\mathcal{F}_\hbar^\Phi} p^\Phi = \\ &= \left( (\varepsilon_Q \circ_{\mathcal{F}_\hbar^\Phi} p^\Phi) \otimes_{\mathcal{F}_\hbar^\Phi} (\varepsilon_Q \circ_{\mathcal{F}_\hbar^\Phi} p^\Phi) \right) \circ_{\mathcal{F}_\hbar^\Phi} \Delta_Q \circ_{\mathcal{F}_\hbar^\Phi} p^\Phi = \\ &= \left( (\varepsilon_Q \otimes_{\mathcal{F}_\hbar^\Phi} \varepsilon_Q) \circ_{\mathcal{F}_\hbar^\Phi} \Delta_Q \right) \circ_{\mathcal{F}_\hbar^\Phi} p^\Phi = \varepsilon_Q \circ_{\mathcal{F}_\hbar^\Phi} p^\Phi = \varepsilon_Q. \end{aligned}$$

□

So finally we can use the lemma 11.11 to equip  $(Q \hat{\otimes} A, p^\Phi)$  with a quasi-coalgebra structure

$$(11.6) \quad \Delta_Q^\Phi := (r^{-1} \otimes_A s^{-1}) \circ \Delta'_Q \quad \text{and} \quad \varepsilon_Q^\Phi := \varepsilon_Q.$$

## 12. THE TWIST

We have two quasi-monoidal functors

$$F_1 : \mathcal{P}_\hbar^\Phi = \mathcal{P}_\hbar \xrightarrow{\text{forg}} \mathcal{V}_{\mathbb{K}[[\hbar]]}^{\text{cpl}}; \quad F_2 : \mathcal{P}_\hbar^\Phi \xrightarrow{\hat{\otimes} A} \mathcal{F}_\hbar^\Phi \xrightarrow{\mathbf{h}^\Phi} \mathcal{V}_{\mathbb{K}[[\hbar]]}^{\text{cpl}}$$

. We have also a natural isomorphism between them which we denote by  $\alpha$ :

$$\text{forg} \left( \begin{array}{ccc} \mathcal{P}_\hbar^\Phi & \xrightarrow{\hat{\otimes} A} & \mathcal{F}_\hbar^\Phi \\ \alpha \searrow & & \swarrow \mathbf{h}^\Phi \\ \mathcal{V}_{\mathbb{K}[[\hbar]]}^{\text{cpl}} & & \end{array} \right) : m \in M \mapsto \begin{array}{c} M \quad A \\ \diagdown \quad \diagup \\ \boxed{\tilde{m}^\Phi} \\ \downarrow \\ Q \end{array}.$$

<sup>19</sup>Just use that  $\otimes_{\mathcal{F}_\hbar^\Phi}, \circ_{\mathcal{F}_\hbar^\Phi}, \Delta'_Q$  are modulo  $\hbar$  the same as  $\otimes_{\mathcal{F}_\hbar}, \circ_{\mathcal{F}_\hbar}, \Delta_Q$ .

The two functors define two quasi-bialgebras. Using  $\alpha$  we can identify  $\text{End}(F_1)$  and  $\text{End}(F_2)$  as algebras, but we will get two quasi-bialgebra structures that differ by a twist.<sup>20</sup> The goal of this section is to compute this twist up to the first order in  $\hbar$ .

First we need some computational tools.

**Claim 12.1.** *Let  $y \in S^k \mathfrak{g}^*$  with  $k > 0$ . Then one has*

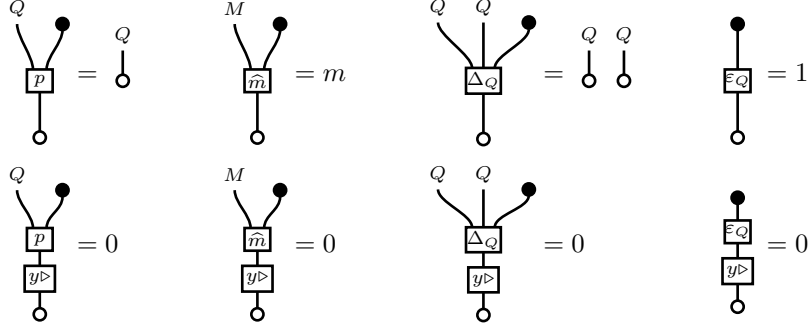

*Proof.* One just uses the defining formulas (9.2), (9.5), (9.3), (9.4) and the remark 9.3.  $\square$

**Corollary 12.2.** *If  $y \in \mathfrak{g}^*$  then we have*

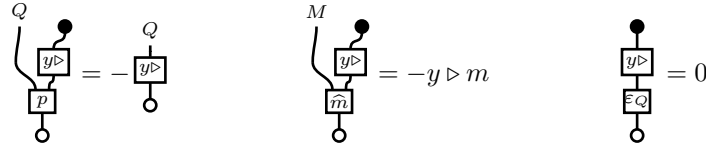

*Proof.* One just uses the  $\mathcal{U}\mathfrak{p}$ -linearity of  $p$ ,  $\hat{m}$  and  $\epsilon_Q$ . For example, the computation for  $\hat{m}$  would look like this:

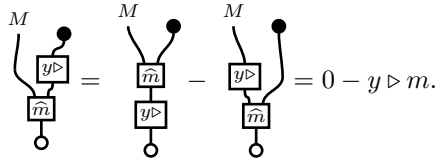

$\square$

**Claim 12.3.** *One has the following congruences modulo  $\hbar^2$ :*



<sup>20</sup>See the remark (5.7).

**Corollary 12.4.** *The natural isomorphism  $\alpha^{-1} : \mathbf{h}^\Phi(M \hat{\otimes} A) \rightarrow M$  is given (modulo  $\hbar^2$ ) by the formula (see the remark 9.4):*

$$\alpha^{-1} \left( \begin{array}{c} M \quad A \\ \diagdown \quad / \\ \boxed{f} \\ | \\ Q \end{array} \right) \equiv \begin{array}{c} M \\ \diagdown \quad / \\ \boxed{f} \\ | \\ \circ \end{array} \pmod{\hbar^2}.$$

**Claim 12.5.**

$$\begin{array}{c} Q \quad Q \quad A \\ \diagdown \quad / \quad / \\ \boxed{\Delta'_Q} \\ | \\ Q \end{array} \equiv \begin{array}{c} Q \quad Q \quad A \\ \diagdown \quad / \quad / \\ \boxed{p} \\ \diagdown \quad / \\ \boxed{\Delta_Q} \\ | \\ Q \end{array} \pmod{\hbar^2}$$

*Proof.* Looking at (11.3) we see that

$$(12.1) \quad \begin{array}{c} Q \quad Q \quad A \\ \diagdown \quad / \\ \boxed{\Delta_Q} \\ | \\ Q \end{array} = \begin{array}{c} Q \quad Q \quad A \\ \diagdown \quad / \quad / \\ \boxed{p^\Phi} \quad \boxed{p^\Phi} \\ \diagdown \quad / \quad / \\ \boxed{\Delta_Q} \\ | \\ \boxed{p^\Phi} \\ | \\ Q \end{array} \equiv \begin{array}{c} Q \quad Q \quad A \\ \diagdown \quad / \quad / \\ \boxed{p} \\ \diagdown \quad / \\ \boxed{\Delta_Q} \\ | \\ Q \end{array} \pmod{\hbar^2}.$$

So, it is enough to see that  $\Delta_Q^\Phi \equiv \Delta'_Q \pmod{\hbar^2}$ . By the relation (11.6) it is thus sufficient to show that  $r$  and  $s$  (see (11.5)) are congruent to  $p^\Phi$  modulo  $\hbar^2$ . On pictures (in  $\mathcal{P}_\hbar^\Phi$ ),  $r$  and  $s$  look like

$$(12.2) \quad r := \begin{array}{c} Q \quad A \\ \diagdown \quad / \\ \boxed{\varepsilon_Q} \\ \diagdown \quad / \\ \boxed{\Delta'_Q} \\ | \\ Q \end{array} \quad \text{and} \quad s := \begin{array}{c} Q \quad A \\ \diagdown \quad / \\ \boxed{\varepsilon_Q} \\ \diagdown \quad / \\ \boxed{\Delta_Q} \\ | \\ Q \end{array}.$$

One easily sees  $s \equiv p \pmod{\hbar^2}$ , since (modulo  $\hbar^2$ ) we can replace  $\Delta'_Q$  in the picture (12.2) by the expression in (12.1) and then use (9.7).

The diagram defining  $r$  contains the braiding which is not congruent to 1 modulo  $\hbar^2$  so it becomes more involved. Note that  $r \in \mathcal{F}_\hbar^\Phi(Q \hat{\otimes} A, Q \hat{\otimes} A)$  satisfies  $r \circ_{\mathcal{F}_\hbar^\Phi} p^\Phi = r$  and thus  $r \in \mathbf{h}^\Phi(Q \hat{\otimes} A)$ . We have an isomorphism between  $\mathbf{h}^\Phi(Q \hat{\otimes} A)$  and  $Q$  which is described explicitly (mod  $\hbar^2$ ) in corollary (12.4). Thus to show that  $r \equiv p^\Phi$

mod  $\hbar^2$  it is enough to check that

$$(12.3) \quad \begin{array}{c} Q \\ \diagdown \\ \boxed{r} \\ \diagup \\ Q \end{array} \equiv \begin{array}{c} Q \\ \diagdown \\ \boxed{p^\Phi} \\ \diagup \\ Q \end{array} \pmod{\hbar^2}.$$

On the right hand side, we replace  $p^\Phi$  by  $p$  (claim 12.3) and then it becomes just  $\begin{array}{c} Q \\ \diagdown \\ \boxed{p} \\ \diagup \\ Q \end{array}$  (claim 12.1). Using (12.1) and then the lemma 11.10 one gets (diagrams in  $\mathcal{P}_\hbar^\Phi$ , congruence modulo  $\hbar^2$ ):

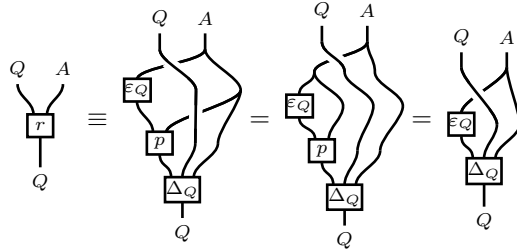

Thus we can compute the left hand side of (12.3) as (diagrams in  $\mathcal{V}_{\mathbb{K}[[\hbar]]}^{\text{cpl}}$ <sup>21</sup>):

$$\begin{array}{c} Q \\ \diagdown \\ \boxed{\epsilon_Q} \\ \diagup \\ Q \end{array} = \begin{array}{c} Q \\ \diagdown \\ \boxed{\epsilon_Q} \\ \diagup \\ Q \end{array} \equiv \begin{array}{c} Q \\ \diagdown \\ \boxed{(1 + \frac{1}{2}\hbar t)} \\ \diagup \\ Q \end{array} = \begin{array}{c} Q \\ \diagdown \\ \circ \\ \diagup \\ Q \end{array} + \frac{\hbar}{2} \cdot \sum_i \left[ \begin{array}{c} \bullet \\ \boxed{e_i \triangleright} \\ \boxed{\epsilon_Q} \\ \circ \end{array} + \begin{array}{c} \bullet \\ \boxed{\epsilon^i \triangleright} \\ \circ \end{array} + \begin{array}{c} \bullet \\ \boxed{\epsilon^i \triangleright} \\ \boxed{\epsilon_Q} \\ \circ \end{array} + \begin{array}{c} \bullet \\ \boxed{\epsilon_i \triangleright} \\ \circ \end{array} \right]$$

Now the first summand in the bracket is 0, since  $\epsilon_A = \begin{array}{c} \bullet \\ A \end{array}$  is  $\mathcal{U}\mathfrak{g}$ -linear and the second is 0 by the corollary 12.2. □

Now we are ready to calculate our twist. Let's recall what we mean by it. We have two functors  $F_1$  and  $F_2$  and a natural isomorphism  $\alpha$  between them.  $F_1$  is a strict<sup>22</sup> quasi-monoidal functor and let's denote the quasi-monoidal structure on

<sup>21</sup>On a diagram in  $\mathcal{V}_{\mathbb{K}[[\hbar]]}^{\text{cpl}}$  by  $\bowtie$  we mean  $\boxed{\exp \frac{\hbar t}{2}}$ . It is meaningful only if both strands

are  $\mathcal{U}\mathfrak{p}$ -modules. In our case it is so, since they are images of objects in  $\mathcal{P}_\hbar$  via the functor  $\mathcal{P}_\hbar \xrightarrow{\text{forg}} \mathcal{V}_{\mathbb{K}[[\hbar]]}^{\text{cpl}}$ .

<sup>22</sup>By "strict" we mean that the quasi-monoidal structure is given by the identity isomorphisms in  $\mathcal{V}_{\mathbb{K}[[\hbar]]}^{\text{cpl}}$ .

$F_2$  by  $\lambda_{M,N} : F_2(M) \otimes F_2(N) \rightarrow F_2(M \otimes N)$ . Then we want to compute

$$F_1(M) \otimes F_1(N) \xrightarrow{\alpha_M \otimes \alpha_N} F_2(M) \otimes F_2(N) \xrightarrow{\lambda_{M,N}} F_2(M \otimes N) \rightarrow \xrightarrow{\alpha_{M \otimes N}^{-1}} F_1(M \otimes N) = F_1(M) \otimes F_1(N) .$$

The composition  $\lambda_{M,N} \circ (\alpha_M \otimes \alpha_N)$  assigns to  $m \otimes n \in F_1(M) \otimes F_1(N)$  the following

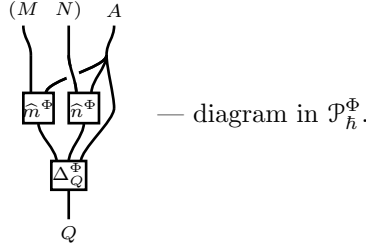

By the corollary 12.4,  $\alpha_{M \otimes N}^{-1}$  assigns to it (modulo  $\hbar^2$ )

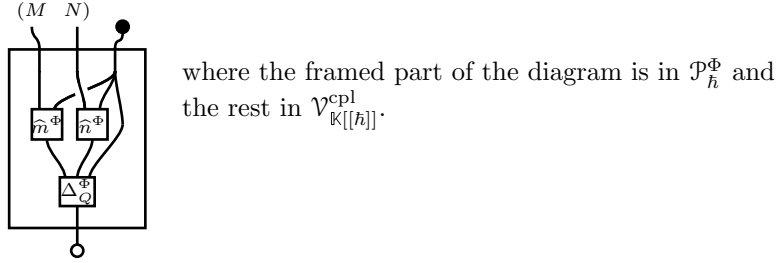

Since the associativity isomorphisms in  $\mathcal{P}_\hbar^\Phi$  viewed in  $\mathcal{V}_{\mathbb{K}[[\hbar]]}^{\text{cp1}}$  are identity modulo  $\hbar^2$ , we can (modulo  $\hbar^2$ ) consider the above diagram as a diagram entirely in  $\mathcal{V}_{\mathbb{K}[[\hbar]]}^{\text{cp1}}$ . Using the claim 12.3 we are thus interested in (diagrams in  $\mathcal{V}_{\mathbb{K}[[\hbar]]}^{\text{cp1}}$  <sup>21</sup>):

$$(12.4) \quad \begin{aligned} & \begin{array}{c} M \quad N \\ \text{Diagram 1} \end{array} = \begin{array}{c} M \quad N \\ \text{Diagram 2} \end{array} = \begin{array}{c} M \quad N \\ \text{Diagram 3} \end{array} = \\ & = \begin{array}{c} M \quad N \\ \text{Diagram 4} \end{array} + \hbar \left( \begin{array}{c} M \quad N \\ \text{Diagram 5} \end{array} + \begin{array}{c} M \quad N \\ \text{Diagram 6} \end{array} \right) + o(\hbar) \end{aligned}$$



we get from the theorem 4.2 of Drinfeld that the classical limit  $(\mathfrak{p}, \delta'_\mathfrak{p}, \varphi'_\mathfrak{p})$  is obtained from  $(\mathfrak{p}, \delta_\mathfrak{p}, \varphi_\mathfrak{p})$  via twisting by

$$f = \frac{1}{2}(e_i \otimes e^i - e^i \otimes e_i) .$$

13.3.  $\text{End}(\mathcal{F}_\hbar^\Phi \xrightarrow{\mathbf{h}^\Phi} \mathcal{V}_{\mathbb{K}[[\hbar]]}^{\text{cpl}})$  is a **quantization of  $(\mathfrak{g}, \delta, \varphi)$** . Let's denote by  $(\mathfrak{g}, \delta', \varphi')$  the classical limit of  $\mathcal{U}\mathfrak{g}[[\hbar]] = \text{End}(\mathcal{F}_\hbar^\Phi \xrightarrow{\mathbf{h}^\Phi} \mathcal{V}_{\mathbb{K}[[\hbar]]}^{\text{cpl}})$ . The goal is to show that  $(\mathfrak{g}, \delta', \varphi') = (\mathfrak{g}, \delta, \varphi)$ . The quasi-bialgebra homomorphism (13.1) induces a quasi-Lie bialgebra homomorphism

$$(\mathfrak{g}, \delta', \varphi') \rightarrow (\mathfrak{p}, \delta'_\mathfrak{p}, \varphi'_\mathfrak{p})$$

that, thought about as a linear map  $\mathfrak{g} \rightarrow \mathfrak{p}$ , is just the ordinary inclusion by the lemma 11.8. In other words, the quasi-Lie bialgebra structure  $(\mathfrak{g}, \delta', \varphi')$  is just the restriction of the quasi-Lie bialgebra structure  $(\mathfrak{p}, \delta'_\mathfrak{p}, \varphi'_\mathfrak{p})$ . And this is precisely  $(\mathfrak{g}, \delta, \varphi)$  by the lemma 4.5.

## APPENDIX A. TOPOLOGICAL VECTOR SPACES

We consider our base field  $\mathbb{K}$  to have discrete topology. By saying “topological vector space”, we also mean that the topology is linear, i.e. it has a basis of neighborhoods of 0 consisting of vector subspaces. Most results mentioned here can be found in [5].

### A.1. Completion.

**Definition A.1.** By a completion  $\hat{M}$  (also denoted  $\text{compl}(M)$ ) of a topological vector space  $M$  we mean

$$\hat{M} := \varprojlim_U M/U$$

where we take the limit with respect to the partially ordered set of open vector subspaces of  $M$ . (Note that the spaces  $M/U$  have discrete topology.)

**Lemma A.2.** Let  $\mathcal{J}$  be a category and  $F : \mathcal{J} \rightarrow \mathbf{Top}$  a functor. We denote by  $\pi_j$  the canonical maps  $\pi_j : \lim F \rightarrow F(j)$ ;  $j \in \text{ob}(\mathcal{J})$ . Let  $M \in \text{ob}(\mathbf{Top})$  and let's have a natural (in  $j \in \text{ob}(\mathcal{J})$ ) transformation  $\phi_j : M \rightarrow F(j)$ . Let's denote by  $\tilde{\phi} : M \rightarrow \lim F$  the unique continuous map satisfying  $\phi_j = \pi_j \circ \tilde{\phi}$ ;  $\forall j \in \text{ob}(\mathcal{J})$ .

If all  $\phi_j$  have a dense image and  $\mathcal{J}$  is cofiltered<sup>24</sup> then  $\tilde{\phi}$  has also a dense image.

*Proof.* The topology on  $\lim F$  is generated by a subbase

$$\mathcal{S} := \{ \pi_j^{-1}(U) \mid j \in \text{ob}(\mathcal{J}) \text{ and } U \subset F(j) \text{ open} \} .$$

Let's show that  $\mathcal{S}$  is actually a base. Take  $a, b \in \text{ob}(\mathcal{J})$  and  $A \subset F(a)$ ,  $B \subset F(b)$  open subsets. We want to show that  $\pi_a^{-1}(A) \cap \pi_b^{-1}(B) \in \mathcal{S}$ . Since  $\mathcal{J}$  is cofiltered,

<sup>24</sup>Actually we need just that  $\forall a, b \in \text{ob}(\mathcal{J})$  we can find an object  $c$  and morphisms  $\alpha : c \rightarrow a$ ;  $\beta : c \rightarrow b$ .

$\exists j \in \text{ob}(\mathcal{J})$  and morphisms  $\alpha \in \mathcal{J}(j, a)$ ;  $\beta \in \mathcal{J}(j, b)$ . The commutative diagram

$$\begin{array}{ccccc}
 & & & & F(a) \\
 & & & \nearrow & \\
 & & F\alpha & & \\
 & & \nearrow & & \\
 & & F(j) & & \\
 & & \searrow & \nearrow & \\
 & & F\beta & & F(b) \\
 & & \searrow & & \\
 & & \lim F & & \\
 \uparrow \pi_j & & \nearrow \pi_a & & \nearrow \pi_b \\
 & & & & 
 \end{array}$$

gives us

$$\pi_a^{-1}(A) = \pi_j^{-1}\left((F\alpha)^{-1}(A)\right) \quad \text{and} \quad \pi_b^{-1}(B) = \pi_j^{-1}\left((F\beta)^{-1}(B)\right).$$

Thus we get

$$\pi_a^{-1}(A) \cap \pi_b^{-1}(B) = \pi_j^{-1}\left((F\alpha)^{-1}(A) \cap (F\beta)^{-1}(B)\right) \in \mathcal{S}.$$

Now to show that  $\text{Im}(\tilde{\phi})$  is dense in  $\lim F$ , we want for any  $\pi_j^{-1}(U) \in \mathcal{S}$  find an element  $m \in M$  s.t.  $\tilde{\phi}(m) \in \pi_j^{-1}(U)$ . That is, we want an  $m \in M$  s.t.  $\phi_j(m) \in U$ . And it exists because  $\phi_j$  has a dense image.  $\square$

**Corollary A.3.** *The canonical map  $M \xrightarrow{i} \hat{M}$  has a dense image.*

**Definition A.4.** A topological vector space  $M$  is called complete if  $M = \hat{M}$ . Note that a complete vector space is automatically Hausdorff.

**Definition A.5.** Denote by  $\mathcal{V}$  the category of vector spaces and linear maps, by  $\mathcal{V}^{\text{top}}$  the category of topological vector spaces and continuous linear maps and by  $\mathcal{V}^{\text{haus}}$ ,  $\mathcal{V}^{\text{cpl}}$  its full subcategories of Hausdorff vector spaces and of complete vector spaces. All these categories are enriched over  $(\mathcal{V}, \otimes)$ .

**Proposition A.6.** *Let  $M \in \text{ob}(\mathcal{V}^{\text{top}})$ . The natural map  $M \xrightarrow{i} \hat{M}$  has the following universal property. If  $N$  is complete and  $f : M \rightarrow N$  is continuous linear, then there is a unique continuous  $\hat{f} : \hat{M} \rightarrow N$  that satisfies  $f = \hat{f} \circ i$ .*

$$\begin{array}{ccc}
 M & \xrightarrow{i} & \hat{M} \\
 & \searrow f & \downarrow \exists! \hat{f} \\
 & & N
 \end{array}$$

*Proof.* The uniqueness comes from  $N$  being Hausdorff and  $i$  having a dense image (A.3). Since  $N = \varprojlim_V N/V$ , in order to define  $\hat{f}$  we need to define maps  $\hat{M} \rightarrow N/V$  in some coherent way. We take them to be the compositions

$$\hat{M} \rightarrow M/f^{-1}(V) \xrightarrow{f/V} N/V$$

where the first map is the canonical map  $\varprojlim M/U \rightarrow M/f^{-1}(V)$  and  $f/V$  is defined by the commutativity of the diagram:

$$\begin{array}{ccc} M & \xrightarrow{f} & N \\ \downarrow & & \downarrow \\ M/f^{-1}V & \xrightarrow{f/V} & N/V \end{array}$$

□

As a consequence, the forgetful functor  $\mathcal{V}^{\text{cpl}} \rightarrow \mathcal{V}^{\text{top}}$  is right adjoint to  $M \mapsto \hat{M} : \mathcal{V}^{\text{top}} \rightarrow \mathcal{V}^{\text{cpl}}$  and thus preserves limits. We formulate this as

**Proposition A.7.** *A limit (in  $\mathcal{V}^{\text{top}}$ ) of complete vector spaces is again complete.*

**Corollary A.8.** *A topological vector space is complete if and only if it can be written as a limit of discrete vector spaces.*

Similarly, as the functor  $M \mapsto \hat{M} : \mathcal{V}^{\text{top}} \rightarrow \mathcal{V}^{\text{cpl}}$  is a left adjoint, we get:

**Proposition A.9.** *The functor  $M \mapsto \hat{M} : \mathcal{V}^{\text{top}} \rightarrow \mathcal{V}^{\text{cpl}}$  preserves (small) colimits.*

**A.2. Tensor products.** Let  $M, N \in \text{ob}(\mathcal{V}^{\text{top}})$  be topological vector spaces (not necessarily complete). We equip  $M \otimes N$  with a linear topology generated by neighborhoods of 0 of the form

$$(U \otimes N) + (M \otimes V)$$

where  $U$  and  $V$  range over the open linear subspaces of  $M$  and  $N$  respectively. This turns  $\mathcal{V}^{\text{top}}$  into a symmetric monoidal category with discrete  $\mathbb{K}$  for the unit object. Note that  $M \otimes N$  can be defined as a space with a universal bilinear map  $M \times N \rightarrow M \otimes N$ , continuous in some sense.

We also define  $\hat{\otimes}$  as  $M \hat{\otimes} N := \widehat{M \otimes N}$ . It satisfies the usual universal property in  $\mathcal{V}^{\text{cpl}}$  and turns it into a symmetric monoidal category.

*Remark A.10.* From the universal properties one can show that for  $M, N \in \text{ob}(\mathcal{V}^{\text{top}})$

$$M \hat{\otimes} N = \hat{M} \hat{\otimes} \hat{N}.$$

**A.3. Tensor product and colimits.** Recall that in the category of modules over some commutative ring, the functor  $\_ \otimes X$  is a left adjoint and thus commutes with all (small) colimits.

**Example A.11.** In  $\mathcal{V}^{\text{top}}$ ,  $X \otimes \_$  does not commute with infinite coproducts. As an example, take  $Y$  infinite dimensional discrete. If  $(y_i)_{i \in I}$  is a basis of  $Y$  then

$$Y = \bigoplus_{i \in I} \mathbb{K} \cdot y_i.$$

$X \otimes Y$  has a topology base of formed by subspaces of the form  $V \otimes Y$ , where  $V \subset X$  is an open subspace. On the other hand the topology on  $\bigoplus_i (X \otimes y_i)$  is generated by the subspaces of the form  $\bigoplus_i (V_i \otimes y_i)$  where  $V_i \subset X$  are open subspaces. Thus  $\bigoplus_i (X \otimes y_i)$  has in general much more open sets than  $X \otimes Y$ . (Take for example  $X$  infinite dimensional with the base formed by subspaces of finite codimension.)

**Proposition A.12.**  $X \otimes \_ : \mathcal{V}^{\text{top}} \rightarrow \mathcal{V}^{\text{top}}$  commutes with finite colimits.

*Proof.* It is enough to show this for direct sums and cokernels.

To show  $X \otimes (M \oplus N) \cong (X \otimes M) \oplus (X \otimes N)$  for  $M, N \in \text{ob}(\mathcal{V}^{\text{top}})$  we observe that the two topology bases are equivalent:

$$\{(Y \otimes (M \oplus N)) + (X \otimes (U \oplus V)) \mid Y \subset_{\text{os}} X, U \subset_{\text{os}} M, V \subset_{\text{os}} N\}$$

$$\{(Y_1 \otimes M + X \otimes U) \oplus (Y_2 \otimes N + X \otimes V) \mid Y_1, Y_2 \subset_{\text{os}} X, U \subset_{\text{os}} M, V \subset_{\text{os}} N\}$$

The topologies of  $X \otimes (M/N)$  and of  $(X \otimes M)/(X \otimes N)$  for  $N \subset M \in \text{ob}(\mathcal{V}^{\text{top}})$  are given by the bases:

$$\{(Y \otimes (M/N)) + (X \oplus U/N) \mid Y \subset_{\text{os}} X, N \subset U \subset_{\text{os}} M\}$$

$$\left\{ (Y \otimes M + X \otimes U)/(X \otimes N) \mid Y \subset_{\text{os}} X, N \subset_{\text{os}} M \text{ such that} \right. \\ \left. (Y \otimes M + X \otimes U) \supset X \otimes N \right\}$$

Since the condition  $(Y \otimes M + X \otimes U) \supset X \otimes N$  just means  $N \subset U$ , these two bases are easily seen to be equal.  $\square$

**Corollary A.13.** *In the category of complete vector spaces,  $X \hat{\otimes} \_ : \mathcal{V}^{\text{cpl}} \rightarrow \mathcal{V}^{\text{cpl}}$  commutes with finite colimits for any  $X \in \text{ob}(\mathcal{V}^{\text{cpl}})$ .*

*Proof.* Take a functor  $\mathcal{I} \rightarrow \mathcal{V}^{\text{cpl}} : i \mapsto N_i$  where  $\mathcal{I}$  is a finite category and  $i \in \text{ob}(\mathcal{I})$ . Let's denote by

$$\underset{\rightarrow}{\text{colim}}^{\mathcal{V}^{\text{cpl}}} N_i \quad \text{and} \quad \underset{\rightarrow}{\text{colim}}^{\mathcal{V}^{\text{top}}} N_i$$

the colimits in  $\mathcal{V}^{\text{cpl}}$  and in  $\mathcal{V}^{\text{top}}$  respectively. We use the previous proposition, the fact that completion commutes with colimits (Proposition A.9), the remark A.10 and  $\text{compl}(N_i) = N_i$  to calculate

$$\begin{aligned} \underset{\rightarrow}{\text{colim}}^{\mathcal{V}^{\text{cpl}}}(X \hat{\otimes} N_i) &= \underset{\rightarrow}{\text{colim}}^{\mathcal{V}^{\text{cpl}}} \text{compl}(X \otimes N_i) \cong \text{compl} \underset{\rightarrow}{\text{colim}}^{\mathcal{V}^{\text{top}}}(X \otimes N_i) = \\ &\cong \text{compl}(X \otimes \underset{\rightarrow}{\text{colim}}^{\mathcal{V}^{\text{top}}} N_i) = X \hat{\otimes} \underset{\rightarrow}{\text{colim}}^{\mathcal{V}^{\text{top}}} N_i = \\ &= X \hat{\otimes} \underset{\rightarrow}{\text{compl}}^{\mathcal{V}^{\text{top}}}(N_i) \cong X \hat{\otimes} \underset{\rightarrow}{\text{colim}}^{\mathcal{V}^{\text{cpl}}} \text{compl} N_i = X \hat{\otimes} \underset{\rightarrow}{\text{colim}}^{\mathcal{V}^{\text{cpl}}} N_i. \end{aligned}$$

$\square$

#### A.4. Strong topology on $\mathcal{V}^{\text{top}}(M, N)$ .

**Definition A.14.** A topological vector space  $K$  is called *totally bounded* (we abbreviate this to *bounded*) iff  $K/V$  is finite dimensional  $\forall V \subset_{\text{os}} K$ .  $K$  is called *compact* if it is bounded and complete.

**Claim A.15.** *If  $X$  is bounded and discrete then it is finite dimensional.*

**Definition A.16.** The *strong topology* on  $\mathcal{V}^{\text{top}}(M, N)$  is defined by the basis of neighborhoods of 0 of the form

$$\{f : M \rightarrow N \quad \text{s.t.} \quad f(K) \subset V\}$$

where  $K \subset_{\text{bs}} M$  and  $V \subset_{\text{os}} N$ .

*Remark A.17.* In other words, the strong topology is the initial linear topology with respect to the maps (the targets are discrete):

$$\mathcal{V}^{\text{top}}(M, N) \rightarrow \mathcal{V}^{\text{top}}(K, N/V)$$

where  $K \subset M$  ranges through the bounded and  $V \subset N$  through the open subspaces.

We denote  $M^* := \mathcal{V}^{\text{top}}(M, \mathbb{K})$  equipped with the strong topology.

*Remark A.18.* Note that if  $K$  is bounded then  $K^*$  is discrete. If  $X$  is discrete then  $X^*$  is compact.

**A.5.  $\mathcal{V}^{\text{top}}$ -categories.** We will equip the hom-sets  $\mathcal{V}^{\text{top}}(X, Y)$  with the strong topology. Note that the composition maps

$$\mathcal{V}^{\text{top}}(Y, Z) \otimes \mathcal{V}^{\text{top}}(X, Y) \rightarrow \mathcal{V}^{\text{top}}(X, Z)$$

are not continuous in general and so  $\mathcal{V}^{\text{top}}$  is not enriched over itself (by considering the strong topologies). One can however introduce the following notion:

**Definition A.19.** By a  $\mathcal{V}^{\text{top}}$ -category we mean a monoidal category  $\mathcal{C}$  enriched over vector spaces whose hom-sets are also equipped with linear topologies in such a way that

- the tensor product maps

$$\mathcal{C}(X_1, Y_1) \otimes \mathcal{C}(X_2, Y_2) \rightarrow \mathcal{C}(X_1 \otimes X_2, Y_1 \otimes Y_2)$$

are continuous.

- The composition maps are non necessarily continuous, but the maps

$$\begin{aligned} g &\mapsto g \circ f && \text{for } f \text{ fixed} \\ f &\mapsto g \circ f && \text{for } g \text{ fixed} \end{aligned}$$

are continuous.

**Example A.20.**  $\mathcal{V}^{\text{top}}$  and  $\mathcal{V}^{\text{cpl}}$  are  $\mathcal{V}^{\text{top}}$ -categories.

The following lemma is the reason why we like this type of categories:

**Lemma A.21.** *Let  $\mathcal{C}$  be a  $\mathcal{V}^{\text{top}}$ -category and  $C \in \text{ob}(\mathcal{C})$ . Then the functor  $\mathbf{h}_C$  represented by  $C$  is a functor to  $\mathcal{V}^{\text{top}}$ . A coalgebra structure on  $C$  makes  $\mathbf{h}_C$  into a quasi-monoidal functor to  $\mathcal{V}^{\text{top}}$ . More generally, the same is true for functors represented by direct summands.*

**A.6. Some properties of strong topology.** The goal of this subsection is Claim A.29 that basically says that under some conditions one has  $\text{Hom}(M, N) = N \hat{\otimes} M^*$ .

**Claim A.22.** *If  $X$  is discrete then  $M \hat{\otimes} X = \varprojlim_V ((M/V) \otimes X)$ ;  $V \subset_{\text{os}} N$ .*

**Claim A.23.** *If  $K$  is bounded and  $N$  is complete then (as topological vector spaces)*

$$\mathcal{V}^{\text{top}}(K, N) = \varprojlim_V \mathcal{V}^{\text{top}}(K, N/V)$$

where  $V$  ranges through the open subspaces of  $N$ .

*Proof.* The equality of sets follows from  $N = \varprojlim_V N/V$  and the definition of the limit. The equality of topologies comes from Remark A.17.  $\square$

**Claim A.24.** *If  $K$  is bounded and  $X$  discrete then  $\mathcal{V}^{\text{top}}(K, X) = X \otimes K^*$ . (Since both  $X$  and  $K^*$  are discrete, it equals also  $X \hat{\otimes} K^*$ .)*

*Proof.* Since both  $\mathcal{V}^{\text{top}}(K, X)$  and  $X \otimes K^*$  are discrete, it is enough to show the equality of vector spaces. One has a natural monomorphism  $X \otimes K^* \rightarrow \mathcal{V}^{\text{top}}(K, X)$ . We just need to show it is surjective. Take  $f \in \mathcal{V}^{\text{top}}(K, X)$ .  $\text{Ker}(f)$  is open and thus  $K/\text{Ker}(f)$  is finite dimensional discrete. Thus the bottom arrow of the following commutative diagram is an isomorphism:

$$\begin{array}{ccc} X \otimes K^* & \longrightarrow & \mathcal{V}^{\text{top}}(K, X) \\ \uparrow & & \uparrow \\ X \otimes (K/\text{Ker}(f))^* & \xrightarrow{\cong} & \text{Hom}(K/\text{Ker}(f), X) \end{array}$$

One can regard  $f$  as an element in  $\text{Hom}(K/\text{Ker}(f), X)$  and a simple diagram chase finishes the argument.  $\square$

**Claim A.25.** *If  $K$  is bounded and  $N$  complete then  $\mathcal{V}^{\text{top}}(K, N) = N \hat{\otimes} K^*$ .*

*Proof.*

$$\mathcal{V}^{\text{top}}(K, N) = \varprojlim_V \mathcal{V}^{\text{top}}(K, N/V) = \varprojlim_V \left( (N/V) \hat{\otimes} K^* \right) = N \hat{\otimes} K^*.$$

The first equality is from Claim A.23, the second from Claim A.24 and the last from Claim A.22  $\square$

**Claim A.26.** *Let  $M = \bigoplus_i M_i$  for  $M_i$  Hausdorff,  $i \in I$  and let  $K$  be a bounded subspace of  $M$ . Then  $K$  is contained in a sum of finitely many  $M_i$ .*

*Proof.* From the universal property of  $\bigoplus$  we see that the projections  $\pi_m : \bigoplus_i M_i \rightarrow M_m$  are continuous for each  $m$ . We want to show that the set

$$J := \{m \in I \mid \pi_m K \text{ is nonzero}\}$$

is finite. Suppose it is not the case. We can replace each  $M_j$ ,  $j \in J$  by  $\pi_j(K)$  and thus suppose that  $\pi_j(K) = M_j$ . Further we choose whatever nonzero continuous functional  $f_j : M_j \rightarrow \mathbb{K}$  (here we need  $M_j$  Hausdorff). This will give us a continuous map  $\bigoplus_{j \in J} f_j : \bigoplus_{i \in I} M_i \rightarrow \bigoplus_{j \in J} \mathbb{K}_j$  (here all  $\mathbb{K}_i = \mathbb{K}$ ) and thus we can replace all  $M_i$  by  $\mathbb{K}_j$  and  $K$  by its image. Finally we are in a situation where we have a bounded vector subspace  $K$  of  $\bigoplus_{j \in J} \mathbb{K}_j$  s.t.  $\pi_j(K) = \mathbb{K}$ . Since  $K$  is a subspace of a discrete space, it is itself discrete and thus finite dimensional (claim A.15). But then only finitely many of the projections  $\pi_j(K)$  can be nonzero.  $\square$

**Claim A.27.** *Let  $M_i, N \in \text{ob}(\mathcal{V}^{\text{haus}})$ . Then  $\mathcal{V}^{\text{top}}(\bigoplus_i M_i, N) = \prod_i \mathcal{V}^{\text{top}}(M_i, N)$  as topological vector spaces.*

*Proof.* Surely, we have the equality of vector spaces (just use the universal property of  $\bigoplus$ ). So we have two topologies  $\mathcal{T}, \mathcal{T}'$  on the same space  $\mathcal{V}^{\text{top}}(\bigoplus_i M_i, N)$ . The basis of neighborhoods of 0 in  $\mathcal{T}$  is formed by the subspaces

$$U_{K,V} := \left\{ f \in \mathcal{V}^{\text{top}}\left(\bigoplus_i M_i, N\right) \mid f(K) \subset V \right\}$$

where  $K \subset_{\text{bs}} \bigoplus M_i$  and  $V \subset_{\text{os}} N$ . In  $\mathcal{T}'$ , the basis of neighborhood of 0 is given by the sets:

$$U'_{K_{i_1}, \dots, K_{i_m}; V} := \left\{ f \in \mathcal{V}^{\text{top}}\left(\bigoplus_i M_i, N\right) \mid f\left(\bigoplus_{j=1}^m K_{i_j}\right) \subset V \right\}$$

where  $\{i_1, \dots, i_m\}$  is a finite subset of the index set,  $K_{i_j} \subset_{\text{bs}} M_{i_j}$  and  $V \subset_{\text{os}} N$ .

Since  $U'_{K_{i_1}, \dots, K_{i_m}; V} = U_{K_{i_1} \oplus \dots \oplus K_{i_m}; V}$ , we see that  $\mathcal{T}' \subset \mathcal{T}$ . To show  $\mathcal{T} \subset \mathcal{T}'$  we need to any  $U_{K, V}$  find a smaller  $U'_{K_{i_1}, \dots, K_{i_m}; V'}$ . From the claim A.26 we have indices  $i_1, \dots, i_m$ , s.t.  $K \subset \bigoplus_{j=1}^m M_{i_j}$  and thus it is enough to take  $K_{i_j} := \pi_{i_j}(K)$  (here  $\pi_k : \bigoplus_i M_i \rightarrow M_k$  denotes the natural projection) and  $V' := V$ .  $\square$

**Claim A.28.** *Let  $X_i$  be discrete topological vector spaces indexes by  $i \in I$  and  $N$  be a complete vector space. Then  $\prod_i (N \hat{\otimes} X_i) = N \hat{\otimes} \prod_i X_i$  as topological vector spaces.*

*Proof.* The subspaces  $\prod_{k \in I \setminus J} X_k$ , where  $J$  ranges through finite subsets of  $I$ , form a base of neighborhoods of 0 in  $\prod_i X_i$ . Thus ( $V$  in the limits are open subspaces of  $N$  and  $J$  are finite subsets of  $I$ )

$$\begin{aligned} N \hat{\otimes} \prod_i X_i &\stackrel{1}{=} \varprojlim_{V, J} N/V \otimes \left( \prod_{i \in I} X_i / \prod_{k \in I \setminus J} X_k \right) \stackrel{2}{=} \varprojlim_J \varprojlim_V \left( N/V \otimes \prod_{j \in J} X_j \right) = \\ &\stackrel{3}{=} \varprojlim_J \prod_{j \in J} \varprojlim_V \left( N/V \otimes X_j \right) \stackrel{4}{=} \prod_{i \in I} N \hat{\otimes} X_i. \end{aligned}$$

In 4 we used Claim A.22.  $\square$

**Claim A.29.** *Let  $M = \bigoplus_i K_i$  where  $K_i$  are bounded and Hausdorff and let  $N$  be complete. Then  $\mathcal{V}^{\text{top}}(M, N) = N \hat{\otimes} M^*$ .*

*Proof.*

$$\begin{aligned} \mathcal{V}^{\text{top}}(M, N) &= \mathcal{V}^{\text{top}}\left(\bigoplus_i K_i, N\right) \stackrel{1}{=} \prod_i \mathcal{V}^{\text{top}}(K_i, N) \stackrel{2}{=} \prod_i (N \hat{\otimes} K_i^*) = \\ &\stackrel{3}{=} N \hat{\otimes} \prod_i K_i^* \stackrel{4}{=} N \hat{\otimes} \left(\bigoplus_i K_i\right)^* = N \hat{\otimes} M^* \end{aligned}$$

Here the equalities 1,2,3 and 4 come from Claims A.27, A.25, A.28 and A.27 respectively.  $\square$

## APPENDIX B. UNIVERSAL ENVELOPING ALGEBRA

Let  $V \in \text{ob}(\mathcal{V}^{\text{haus}})$ . We can construct a topological vector space  $TV := \bigoplus_{n \geq 0} V^{\otimes n}$ . We can define topological  $SV$  as a closed subspace of  $TV$ . Since  $TV$  decomposes as a topological vector space into a direct sum  $TV = SV \oplus \text{Ker}(\text{Sym})$  where  $\text{Sym}$  is the symmetrization map, the topology on  $SV$  can be defined as the quotient topology relative to  $TV \rightarrow SV$ .

**Theorem B.1.** *Let  $L$  be a topological Lie algebra. Then as topological vector spaces,  $TL \cong \text{Ker}(\pi) \oplus SL$  where  $\pi : TL \rightarrow UL$  denotes the natural projection. So if we equip  $UL$  with the quotient space topology, the PBW map  $SL \rightarrow UL$  will be an isomorphism of topological vector spaces.*

*Proof.* We will show that for every  $n \in \mathbb{N}$ ,  $T^{\leq n}L = \text{Ker}(\pi^{\leq n}) \oplus S^{\leq n}L$  as topological vector spaces. From the ordinary PBW theorem we know that the composition

$$S^{\leq n}L \hookrightarrow T^{\leq n}L \xrightarrow{\pi^{\leq n}} \mathcal{U}^{\leq n}L$$

is a vector space isomorphism and thus we have  $T^{\leq n}L = \text{Ker}(\pi^{\leq n}) \oplus S^{\leq n}L$  as vector spaces. To see that this is also a direct sum of topological vector spaces we will show that the projection on the second summand

$$p^{\leq n} : T^{\leq n}L = \text{Ker}(\pi^{\leq n}) \oplus S^{\leq n}L \rightarrow S^{\leq n}L$$

is continuous. We do it by induction on  $n$ . Assume that  $p^{\leq n-1}$  is continuous. We have a topological decomposition

$$T^{\leq n}L = T^{\leq n-1}L \oplus S^nL \oplus A^nL$$

where  $A^nL$  is the kernel of the symmetrization map  $T^nL \rightarrow T^nL$ . Since the restrictions

$$p^{\leq n} \Big|_{T^{\leq n-1}L} = p^{\leq n-1} \quad \text{and} \quad p^{\leq n} \Big|_{S^nL} = \text{id}_{S^nL}$$

are continuous, it is enough to check the continuity of  $p|_{A^nL} : A^nL \rightarrow S^{\leq n}L$ .

Denote by  $A_{i,j} \subset A^n$  the subspace of tensors antisymmetric in the  $i$ -th and  $j$ -th indices. We will show in a moment that  $p|_{A_{i,j}}$  is continuous. One has  $A = \sum A_{i,j}$  as a vector space but this does not imply that  $p|_{A^n}$  is also continuous. One can however find a decomposition of  $A$  into a direct sum (in  $\mathcal{V}^{\text{top}}$ )  $A = \bigoplus_{\alpha} A_{\alpha}$  of finitely many subspaces  $A_{\alpha}$  s.t. each  $A_{\alpha}$  is a subset of some  $A_{i,j}$ . Thus  $p|_{A_{\alpha}}$  are continuous and consequently  $p|_{A^n}$  also is.

One such decomposition of  $A$  comes from the standard decomposition  $L^{\otimes n} = \bigoplus_T L^{\otimes n} \cdot c_T$  using the Young symmetrizers  $c_T$  corresponding to the standard tableaux  $T$ . Each  $c_T$  is a composition of the symmetrization with respect to the rows of  $T$  followed by the antisymmetrization in columns. Thus each  $L^{\otimes n} \cdot c_T$  different from  $S^nL$  will be a subset of some  $A_{i,j}$ .

The last thing is the continuity of  $p|_{A_{i,j}}$  which can be proven by finding explicit formulas involving only the Lie brackets and  $p^{\leq n-1}$  which is continuous by the induction hypothesis. For example  $A_{1,2}$  is generated by elements of the form  $(x_1 \otimes x_2 \otimes \dots) - (x_2 \otimes x_1 \otimes \dots)$ . One has

$$\pi\left((x_1 \otimes x_2 \otimes \dots) - (x_2 \otimes x_1 \otimes \dots)\right) = \pi\left([x_1, x_2] \otimes \dots\right)$$

and thus (because  $\text{Ker}(p) = \text{Ker}(\pi)$ ) also

$$p\left((x_1 \otimes x_2 \otimes \dots) - (x_2 \otimes x_1 \otimes \dots)\right) = p^{\leq n-1}\left([x_1, x_2] \otimes \dots\right).$$

Similarly, on  $A_{1,3}$  we get a formula

$$\begin{aligned} & p\left((x_1 \otimes x_2 \otimes x_3 \otimes \dots) - (x_3 \otimes x_2 \otimes x_1 \otimes \dots)\right) = \\ & = p^{\leq n-1}\left(\left([x_1, x_2] \otimes x_3 \otimes \dots\right) + \left(x_2 \otimes [x_1, x_3] \otimes \dots\right) + \left([x_2, x_3] \otimes x_1 \otimes \dots\right)\right). \end{aligned}$$

One gets longer formulas when  $i$  and  $j$  are still further apart.  $\square$

*Remark B.2.* From the proof of the theorem B.1 one can see that as a topological vector space  $\mathcal{U}L = \varinjlim_k \mathcal{U}^{\leq k}L$  and one has topological PBW isomorphisms  $S^{\leq k}L \xrightarrow{\cong} \mathcal{U}^{\leq k}L$ .

We will need the following generalization of the above theorem.

**Theorem B.3.** *Let  $L$  be a topological Lie algebra and  $\pi : TL \rightarrow \mathcal{U}L$  the natural projection. Assume also that  $L$  decomposes into a direct sum  $L = L_1 \oplus L_2$  of topological vector spaces  $L_1, L_2$ . Then  $TL$  decomposes as a topological vector space into a sum*

$$TL = \text{Ker}(\pi) \oplus \left( \bigoplus_{k,l} S^k L_1 \otimes S^l L_2 \right).$$

This implies  $\mathcal{U}L \cong \bigoplus_{k,l} S^k L_1 \otimes S^l L_2$  as a topological vector space.

*Remark B.4.* One can generalize this to any finite number of summands  $L = L_1 \oplus \dots \oplus L_k$ .

*Proof.* We want to show for all  $n \in \mathbb{N}$  that as a topological vector space

$$T^{\leq n} L = \text{Ker}(\pi^{\leq n}) \oplus \left( \bigoplus_{\substack{k,l \\ k+l \leq n}} S^k L_1 \otimes S^l L_2 \right).$$

As before we show by induction that the projection  $p^{\leq n}$  on the second factor is continuous. In the induction step we need to show the continuity of  $p|_{T^n L}$ . We decompose  $T^n L$  as

$$(B.1) \quad T^n L = \bigoplus_{f: \{1, \dots, n\} \rightarrow \{1, 2\}} L_{f(1)} \otimes L_{f(2)} \otimes \dots \otimes L_{f(n)}.$$

We call a pair  $i < j \in \{1, \dots, n\}$  an inversion of  $f : \{1, \dots, n\} \rightarrow \{1, 2\}$  if  $f(i) > f(j)$ . We will show the continuity of  $p|_{L_{f(1)} \otimes \dots \otimes L_{f(n)}}$  by induction on the number of inversions of  $f$ .

As the 0-th step assume that  $f$  has no inversions. This means that  $L_{f(1)} \otimes \dots \otimes L_{f(n)} = T^k L_1 \otimes T^l L_2$  for some  $k + l = n$ . We decompose it as

$$T^k L_1 \otimes T^l L_2 = (S^k L_1 \otimes S^l L_2) \oplus (A^k L_1 \otimes S^l L_2) \oplus (S^k L_1 \otimes A^l L_2) \oplus (A^k L_1 \otimes A^l L_2)$$

and proceed as in the proof of the theorem B.1.

As the induction step we want to prove the continuity of  $p|_{L_{f(1)} \otimes \dots \otimes L_{f(n)}}$  assuming the continuity of  $p|_{L_{f'(1)} \otimes \dots \otimes L_{f'(n)}}$  for all  $f'$  with less inversions than  $f$ .

From the induction on  $n$  we also assume that  $p^{\leq n-1}$  is continuous. We can find a  $k \in \{1, \dots, n-1\}$  s.t.  $f(k) = 2$  and  $f(k+1) = 1$ . For simplicity assume that  $k = 1$ . Define continuous maps

$$\begin{aligned} \alpha : L_2 \otimes L_1 \otimes L_{f(3)} \otimes \dots \otimes L_{f(n)} &\rightarrow L_1 \otimes L_2 \otimes L_{f(3)} \otimes \dots \otimes L_{f(n)} \\ x_1 \otimes x_2 \otimes x_3 \dots &\mapsto x_2 \otimes x_1 \otimes x_3 \otimes \dots \end{aligned}$$

$$\begin{aligned} \beta : L_2 \otimes L_1 \otimes L_{f(3)} \otimes \dots \otimes L_{f(n)} &\rightarrow L \otimes L_{f(3)} \otimes \dots \otimes L_{f(n)} \\ x_1 \otimes x_2 \otimes x_3 \dots &\mapsto [x_1, x_2] \otimes x_3 \otimes \dots \end{aligned}$$

Then for any  $t \in L_{f(1)} \otimes \dots \otimes L_{f(n)}$  we have  $t - \alpha(t) - \beta(t) \in \text{Ker}(\pi) = \text{Ker}(p)$  and thus

$$p^{\leq n}(t) = p^{\leq n}(\alpha(t)) + p^{\leq n-1}(\beta(t)).$$

But  $p^{\leq n} \circ \alpha$  and  $p^{\leq n-1} \circ \beta$  are continuous from the induction hypotheses.  $\square$

**Corollary B.5.** *Recall that  $\mathfrak{p} = \mathfrak{g} \oplus \mathfrak{g}^*$  as a topological vector space and  $\mathfrak{g}$  is a Lie subalgebra of  $\mathfrak{p}$ . This gives us a PBW isomorphism of vector spaces (or even  $\mathcal{U}\mathfrak{g}$ -modules)  $\mathcal{U}\mathfrak{g} \otimes S\mathfrak{g}^* \xrightarrow{\cong} \mathcal{U}\mathfrak{p}$ . On the topological level one gets<sup>25</sup>*

$$\mathcal{U}\mathfrak{p} \cong \underset{k,l}{\operatorname{colim}} \mathcal{U}^{\leq k} \mathfrak{g} \otimes S^{\leq l} \mathfrak{g}^*.$$

*Proof.* One has a commutative diagram

$$\begin{array}{ccc} \underset{k,l}{\operatorname{colim}} S^{\leq k} \mathfrak{g} \otimes S^{\leq l} \mathfrak{g}^* & & \\ \cong \downarrow & \searrow \cong & \\ \underset{k,l}{\operatorname{colim}} \mathcal{U}^{\leq k} \mathfrak{g} \otimes S^{\leq l} \mathfrak{g}^* & \longrightarrow & \mathcal{U}\mathfrak{p} \end{array}$$

where the two downward pointing maps are topological isomorphisms by the theorems B.1 and B.3.  $\square$

*Remark B.6.*  $TL, SL, UL$  are not complete. If we wanted them to be, we could either complete them or (equivalently) define  $\hat{TV} := \bigoplus_{n \geq 0} V^{\hat{\otimes} n}$  and then take  $\hat{SL}, \hat{UL}$  as its quotient spaces. We will however not need it and reserve the notation  $\hat{S}\mathfrak{g}$  for a different space (it will be again a completion of  $S\mathfrak{g}$  but w.r.t. a different topology).

Note that the multiplication map  $TV \otimes TV \rightarrow TV$  will not be continuous in general (the problem is that the topological tensor product does not commute with the infinite direct sums). Our  $TV, SV$  and  $UL$  will be however topological filtered algebras from the following definition.

**Definition B.7.** By a filtered algebra in  $\mathcal{V}^{\text{top}}$  we mean a filtered topological vector space  $B = \underset{i}{\operatorname{colim}} B_i, B_0 \subset B_1 \subset \dots$  that is also a filtered algebra over  $\mathbb{K}$  and the restrictions of the multiplication

$$\mu|_{B_k \otimes B_l} : B_k \otimes B_l \rightarrow B_{k+l}$$

are continuous for all  $k, l$ .

## APPENDIX C. EQUICONTINUOUS MODULES

*Reminder C.1.* Recall from [EK1] that a system of maps  $\{f_x : Y \rightarrow Z\}_{x \in X}$  where  $Y, Z$  are topological vector spaces and  $X$  a set, is said to be equicontinuous if

$$\forall V \subset_{\text{os}} Z; \exists U \subset_{\text{os}} Y; \forall x \in X : f_x(U) \subset V.$$

In our case,  $X$  will also be a topological vector space and the system  $\{f_x : Y \rightarrow Z\}_{x \in X}$  will come from a map  $f : X \otimes Y \rightarrow Z$ . The equicontinuity then means the continuity of  $f : X_{\text{disc}} \otimes Y \rightarrow Z$  where  $X_{\text{disc}}$  is the same vector space as  $X$  but with discrete topology.

<sup>25</sup>Note that since the tensor product (of topological vector spaces) does not commute with colimits, one actually does not have  $\mathcal{U}\mathfrak{p} \cong \mathcal{U}\mathfrak{g} \otimes S\mathfrak{g}^*$ . (A simpler example of this phenomenon is that  $S(V_1 \oplus V_2) \neq SV_1 \otimes SV_2$  as topological vector spaces.)

Let  $L$  be a topological Lie algebra. Following [EK1], an  $L$ -module  $M$  is called an equicontinuous  $L$ -module if the map  $L \rightarrow \mathcal{V}^{\text{top}}(M, M)$  is continuous and the system of maps  $\{x \triangleright \cdot : M \rightarrow M\}_{x \in L}$  is equicontinuous.

In this definition, there are two natural choices for the topology on  $\mathcal{V}^{\text{top}}(M, M)$ : a) the strong topology and b) the weak topology (this is how [EK1] do it). The choice of a) can be expressed as continuity of  $L \otimes M \xrightarrow{\triangleright} M$  w.r.t. the topology on  $L \otimes M$  where a vector subspace  $U \subset L \otimes M$  is open if

- i)  $\exists V \subset_{\text{os}} M$  s.t.  $(L \otimes V) \subset U$  and
- ii)  $\forall K \subset_{\text{bs}} M; \exists T \subset_{\text{os}} L$  s.t.  $(T \otimes K) \subset U$ .

Similarly, to get b) just replace ii) with

- ii')  $\forall m \in M; \exists T \subset_{\text{os}} L$  s.t.  $(T \otimes m) \subset U$ .

Now we can see that the two possibilities are actually equivalent.

*Proof.* Obviously, i) + ii)  $\Rightarrow$  i) + ii'), so we just need the opposite implication. Let  $U \subset L \otimes M$  satisfy i) and ii') and let  $K \subset_{\text{bs}} M$ . By i) we can find  $V \subset_{\text{os}} M$  s.t.  $L \otimes V \subset U$ . Since  $V \cap K$  is open in  $K$ ,  $K/(V \cap K)$  is finite dimensional ( $K$  is bounded) and so there exists a finite number of elements  $m_1, \dots, m_k \in K$  s.t.  $K = (V \cap K) + \mathbb{K}m_1 + \dots + \mathbb{K}m_k$ . By ii') we find  $T_1, \dots, T_k \subset_{\text{os}} M$  s.t.  $T_i \otimes m_i \subset U$ . If we take  $T := \bigcap_{i=1}^k T_i$  we have

$$\begin{aligned} T \otimes K &= T \otimes \left( (V \cap K) + \mathbb{K}m_1 + \dots + \mathbb{K}m_k \right) \subset \\ &\subset L \otimes V + T_1 \otimes m_1 + \dots + T_k \otimes m_k \subset U \end{aligned}$$

□

**Notation C.2.** We denote the above topological vector space by  $L \otimes M$ . More generally, if  $M, N \in \text{ob}(\mathcal{V}^{\text{top}})$  we define a topological vector space  $M \otimes N$  whose underlying vector space is  $M \otimes N$  and where a subspace  $U \subset M \otimes N$  is open iff

- i)  $\exists V \subset_{\text{os}} N$  s.t.  $M \otimes V \subset U$ ;
- ii)  $\forall K \subset_{\text{bs}} N, \exists T \subset_{\text{os}} M$  s.t.  $T \otimes K \subset U$

or equivalently (the same proof as above) ii) can be replaced by

- ii')  $\forall n \in N; \exists T \subset_{\text{os}} M$  s.t.  $T \otimes n \subset U$ .

Note that  $M \otimes N$  is not isomorphic to  $N \otimes M$  in general.

So a succinct definition of an equicontinuous module just says that  $L \otimes M \xrightarrow{\triangleright} M$  is continuous.

**Claim C.3.** *If  $M$  is discrete or if  $N$  is bounded then  $M \otimes N = M \otimes N$ .*

*Remark C.4.* A definition of an equicontinuous  $L$ -module that is often easy to check is the following:

- i) The system of maps  $\{x \triangleright \cdot : M \rightarrow M\}_{x \in L}$  is equicontinuous and
- ii) for any  $m \in M$  the map  $\cdot \triangleright m : L \rightarrow M$  is continuous.

**Example C.5.** If  $L$  is a topological Lie algebra then  $\mathcal{U}L$  is an equicontinuous  $L$ -module (via left multiplication).

*Proof.* We use the definition from Remark C.4. To prove i) we fix  $V \subset_{\text{os}} \mathcal{U}L$  and want to find  $U \subset_{\text{os}} \mathcal{U}L$  s.t.  $L \cdot U \subset V$ . Since  $\mathcal{U}L$  is a filtered algebra, the multiplication maps  $L \otimes \mathcal{U}^{\leq k} L \rightarrow \mathcal{U}^{\leq k+1} L$  are continuous. Thus there exist  $U_k \subset_{\text{os}} \mathcal{U}^{\leq k} L$  s.t.  $L \cdot U_k \subset V$ . Consequently, we can take  $U := \sum_{k=0}^{\infty} U_k$ . It will be

open in  $\mathcal{U}L$  since its intersection with any  $\mathcal{U}^{\leq k}L$  is open and the topology on  $\mathcal{U}L$  is the colimit of topologies on  $\mathcal{U}^{\leq k}L$ .

To prove ii), fix an element  $x \in \mathcal{U}L$ . We want to show that  $\smile \cdot x : L \rightarrow \mathcal{U}L$  is continuous. And it really is, since  $x$  is in some  $\mathcal{U}^{\leq k}L$  and the multiplication map  $L \otimes \mathcal{U}^{\leq k}L \rightarrow \mathcal{U}L$  is continuous.  $\square$

**Claim C.6.** *Let  $M$  be an equicontinuous  $L$ -module. Then for any  $k \in \mathbb{N}$ , the action maps*

$$\mathcal{U}^{\leq k}L \otimes M \xrightarrow{\smile} M$$

are continuous. In other words

- a) the system of maps  $\{x \triangleright \smile : M \rightarrow M\}_{x \in \mathcal{U}^{\leq k}L}$  is equicontinuous;
- b)  $\forall m \in M$ , the map  $\smile \triangleright m : \mathcal{U}^{\leq k}L \rightarrow M$  is continuous.

*Proof.* We will show a) and b) for  $k = 2$ , the proof for higher  $k$  being analogous.

Let's start with a). We know that

$$(C.1) \quad \forall U \subset_{\text{os}} M; \exists U' \subset_{\text{os}} M; \text{ s.t. } (L \triangleright U') \subset U$$

and want to prove

$$\forall U \subset_{\text{os}} M; \exists U' \subset_{\text{os}} M; \text{ s.t. } (L \triangleright L \triangleright U') \subset U$$

This amounts just to using (C.1) two times.

Now let's show b) for  $k = 2$ . Since  $\mathcal{U}^{\leq 2}L$  is a quotient space of  $T^{\leq 2}L$ , we want to show continuity of ( $m \in M$  is fixed)

$$L \otimes L \rightarrow M : x \otimes y \mapsto x \triangleright y \triangleright m.$$

This means that for a given  $U \subset_{\text{os}} M$  we want to find  $V_1, V_2 \subset_{\text{os}} L$  s.t.

$$V_1 \triangleright L \triangleright m \subset U \quad \text{and} \quad L \triangleright V_2 \triangleright m \subset U.$$

Start with  $V_2$ . We know we can find  $U' \subset_{\text{os}} M$  s.t.  $L \triangleright U' \subset U$ . From the continuity of  $\smile \triangleright m : L \rightarrow M$  we can find  $V_2 \subset_{\text{os}} L$  s.t.  $V_2 \triangleright m \subset U'$ .

Now let's find  $V_1$ . Note that

$$V_1 \triangleright L \triangleright m \subset (L \triangleright V_1 \triangleright m) + ([V_1, L] \triangleright m).$$

From the continuity of  $L \otimes L \rightarrow M : x \otimes y \mapsto [x, y] \triangleright m$  we can find  $V_1' \subset_{\text{os}} L$  s.t.  $[V_1', L] \triangleright m \subset U$ . Now take  $V_1 := V_1' \cap V_2$ .  $\square$

**Claim C.7.** *If  $M, N$  are equicontinuous (Hausdorff)  $L$ -modules then  $\hat{M}, M \otimes N, M \hat{\otimes} N$  are also equicontinuous  $L$ -modules.*

#### APPENDIX D. SOME PROPERTIES OF $\heartsuit : \mathcal{G} \rightarrow \mathcal{P}$

We gather here some topological claims needed in Section 8. Throughout, we consider  $\mathcal{U}\mathfrak{g}$  and  $S\mathfrak{g}^*$  as subspaces in  $\mathcal{U}\mathfrak{p}$  (see also Corollary B.5).

**Claim D.1.** *Let  $M$  be an equicontinuous  $\mathfrak{g}$ -module. Then the two systems of subspaces*

$$V_{k,U} := \{f \in \text{Hom}_{\mathcal{U}\mathfrak{g}}^C(\mathcal{U}\mathfrak{p}, M) \mid f(\mathcal{U}^{\leq k}\mathfrak{p}) \subset U\}; \quad k \in \mathbb{N}; U \subset_{\text{os}} M$$

and

$$\tilde{V}_{k,U} := \{f \in \text{Hom}_{\mathcal{U}\mathfrak{g}}^C(\mathcal{U}\mathfrak{p}, M) \mid f(S^{\leq k}\mathfrak{g}^*) \subset U\}; \quad k \in \mathbb{N}; U \subset_{\text{os}} M$$

form two bases of neighborhoods of 0 in  $\text{Hom}_{\mathcal{U}\mathfrak{g}}^C(\mathcal{U}\mathfrak{p}, M)$  (with the strong topology).

*Proof.* By the definition of the strong topology we know that the system

$$V'_{K,U} := \{f \in \text{Hom}_{\mathcal{U}\mathfrak{g}}^C(\mathcal{U}\mathfrak{p}, M) \mid f(K) \subset U\}; \quad K \subset_{\text{bs}} \mathcal{U}\mathfrak{p}; \quad U \subset_{\text{os}} N$$

forms a basis of neighborhoods of 0 in  $\text{Hom}_{\mathcal{U}\mathfrak{g}}^C(\mathcal{U}\mathfrak{p}, M)$ . We will show that in the sequence of bases

$$\{V'_{K,U}\}; \quad \{\tilde{V}_{k,U}\}; \quad \{V_{k,U}\}; \quad \{V'_{K,U}\};$$

each base is finer than the next one.

1.  $\{V'_{K,U}\}$  is finer than  $\{\tilde{V}_{k,U}\}$ . This is clear since  $S^{\leq k}\mathfrak{g}^*$  is bounded ( $\mathfrak{g}^*$  is compact and the tensor product of bounded spaces is bounded).

2.  $\{\tilde{V}_{k,U}\}$  is finer than  $\{V_{k,U}\}$ . Fix  $V_{n,U}$ . Since  $M$  is an equicontinuous  $\mathcal{U}\mathfrak{g}$ -module, we can find an open subspace  $U'$  s.t.  $(\mathcal{U}^{\leq n}\mathfrak{g} \triangleright U') \subset U$ . We want to show that  $\tilde{V}_{n,U'} \subset V_{n,U}$ . Really,  $\mathcal{U}^{\leq n}\mathfrak{p} \subset (\mathcal{U}^{\leq n}\mathfrak{g} \cdot S^{\leq n}\mathfrak{g}^*)$  and thus for any  $f \in \tilde{V}_{n,U'}$  we have

$$f(\mathcal{U}^{\leq n}\mathfrak{p}) \subset \mathcal{U}^{\leq n}\mathfrak{g} \triangleright f(S^{\leq n}\mathfrak{g}^*) \subset \mathcal{U}^{\leq n}\mathfrak{g} \triangleright U' \subset U.$$

3.  $\{V_{k,U}\}$  is finer than  $\{V'_{K,U}\}$ . Fix  $V'_{K,U}$ . We will find an  $n$  s.t.  $K \subset \mathcal{U}^{\leq n}\mathfrak{p}$ , which will imply  $V_{n,U} \subset V'_{K,U}$ . Note that under the topological isomorphism  $\bigoplus_{k=0}^{\infty} S^k\mathfrak{p} = S\mathfrak{p} \xrightarrow{\cong} \mathcal{U}\mathfrak{p}$ ,  $\mathcal{U}^{\leq n}\mathfrak{p}$  corresponds to  $\bigoplus_{k=0}^n S^k\mathfrak{p}$ . So one can use the claim A.26.  $\square$

**Corollary D.2.** *If  $M$  is an equicontinuous  $\mathfrak{g}$ -module then  $\heartsuit M$  is an equicontinuous  $\mathfrak{p}$ -module.*

*Proof.* We use the definition of an equicontinuous module from Remark C.4. To prove i) we need for any  $V_{k,U}$  from Claim D.1 find a  $V' \subset_{\text{os}} \heartsuit M$  s.t.  $\mathfrak{p} \triangleright V' \subset V_{k,U}$ . It is enough to take  $V' = V_{k+1,U}$ .

To check ii) we fix  $f \in \heartsuit M$  and want to show that  $\lrcorner \triangleright f : \mathcal{U}\mathfrak{p} \rightarrow \heartsuit M$  is continuous. That is, for any  $V_{k,U}$  from Claim D.1 we need to find  $V' \subset_{\text{os}} \mathcal{U}\mathfrak{p}$  s.t.  $V' \triangleright f \subset V_{k,U}$  what just means  $f(\mathcal{U}^{\leq k}\mathfrak{p} \cdot V') \subset U$ . Now  $f$  is continuous so  $U' := f^{-1}(U)$  is an open subspace of  $\mathcal{U}\mathfrak{p}$ . So we just need to find  $V' \subset_{\text{os}} \mathcal{U}\mathfrak{p}$  s.t.  $\mathcal{U}^{\leq k}\mathfrak{p} \cdot V' \subset U'$ . And we can really find it since  $\mathcal{U}\mathfrak{p}$  is an equicontinuous  $\mathfrak{p}$ -module (example C.5).  $\square$

**Claim D.3.** *Let  $M$  be an equicontinuous  $\mathfrak{g}$ -module. An  $f \in \text{Hom}_{\mathcal{U}\mathfrak{g}}(\mathcal{U}\mathfrak{p}, M)$  is continuous iff its restriction  $f|_{S\mathfrak{g}^*}$  is.*

*Proof.* Suppose  $f' := f|_{S\mathfrak{g}^*}$  is continuous. One has (corollary B.5)

$$\mathcal{U}\mathfrak{p} \cong \underset{k,l}{\text{colim}} \mathcal{U}^{\leq k}\mathfrak{g} \otimes S^{\leq l}\mathfrak{g}^*$$

so to verify the continuity of  $f$  it is enough to check the continuity of all  $f^{(k,l)} := f|_{\mathcal{U}^{\leq k}\mathfrak{g} \otimes S^{\leq l}\mathfrak{g}^*}$ . We can reconstruct  $f^{(k,l)}$  from  $f'$  as a composition

$$(D.1) \quad f^{(k,l)} : \mathcal{U}^{\leq k}\mathfrak{g} \otimes S^{\leq l}\mathfrak{g}^* \xrightarrow{\text{id} \otimes f'} \mathcal{U}^{\leq k}\mathfrak{g} \otimes M \xrightarrow{\triangleright} M.$$

Now  $\text{id} \otimes f'$  is continuous since  $f'$  is. The second map is continuous as a map  $\mathcal{U}^{\leq k}\mathfrak{g} \otimes M \xrightarrow{\triangleright} M$  but since  $\mathcal{U}^{\leq k}\mathfrak{g}$  is discrete,  $\mathcal{U}^{\leq k}\mathfrak{g} \otimes M = \mathcal{U}^{\leq k}\mathfrak{g} \otimes M$  as topological vector spaces (claim C.3). Hence both maps in (D.1) are continuous and so the composition also is.  $\square$

**Claim D.4.** *Let  $M \in \text{ob}(\mathcal{G})$ . The restriction map  $\heartsuit M = \text{Hom}_{\mathcal{U}\mathfrak{g}}^C(\mathcal{U}\mathfrak{p}, M) \rightarrow \text{Hom}_{\mathbb{K}}^C(S\mathfrak{g}^*, M)$  is an isomorphism of topological vector spaces.*

*Proof.* The restriction map is bijective (claim D.3) and continuous. So it is enough to check that it is also open. This is easy if we use the base of neighborhood of 0 in  $\text{Hom}_{\mathcal{U}\mathfrak{g}}^C(\mathcal{U}\mathfrak{p}, M)$  formed by the sets  $\tilde{V}_{k,U}$  from the claim D.1.  $\square$

**Claim D.5.** *The topological algebra  $(S\mathfrak{g}^*)^*$  is equal to  $\hat{S}\mathfrak{g} := \varprojlim_k S^{\leq k}\mathfrak{g}$  where  $S^{\leq k}\mathfrak{g}$  is discrete with algebra structure  $S^{\leq k}\mathfrak{g} := S\mathfrak{g}/S^{>k}\mathfrak{g}$ .*

*Proof.*  $S^{\leq k}\mathfrak{g}^*$  is a sub-coalgebra of  $S\mathfrak{g}^*$ . This induces algebra homomorphisms  $(S\mathfrak{g}^*)^* \rightarrow (S^{\leq k}\mathfrak{g}^*)^*$  and thus an algebra homomorphism  $(S\mathfrak{g}^*)^* \rightarrow \varprojlim_k (S^{\leq k}\mathfrak{g}^*)^*$ . This map is a topological isomorphism by

$$(S\mathfrak{g}^*)^* = \left(\bigoplus_k S^k\mathfrak{g}^*\right)^* = \prod_k (S^{\leq k}\mathfrak{g}^*)^* = \varprojlim_k \prod_{i=0}^k (S^i\mathfrak{g}^*)^* = \varprojlim_k (S^{\leq k}\mathfrak{g}^*)^*$$

where the second and the last equalities come from Claim A.27. One has further

$$(S^{\leq k}\mathfrak{g}^*)^* = (\text{compl}(S^{\leq k}\mathfrak{g}^*))^* = ((S^{\leq k}\mathfrak{g}))^* = S^{\leq k}\mathfrak{g}$$

where the second and third equality come from the following claim

**Claim D.6.** *If  $X, Y$  are discrete topological vector spaces, then*

- a)  $X^* \hat{\otimes} Y^* = (X \otimes Y)^*$
- b)  $(X^*)^* = X$ .

$\square$

**Claim D.7.** *In the assignment (8.4), the composition on the right hand side is continuous and the assignment itself is continuous w.r.t the strong topologies.*

*Proof.* By the claim D.4 it is enough to check the same for the map

$$\begin{aligned} & \text{Hom}_{\mathbb{K}}^C(S\mathfrak{g}^*, M) \longrightarrow \text{Hom}_{\mathbb{K}}^C(S\mathfrak{g}^*, M) \\ & s \longmapsto \left( S\mathfrak{g}^* \xrightarrow{\Delta} S\mathfrak{g}^* \otimes S\mathfrak{g}^* \xrightarrow{S \otimes s} S\mathfrak{g}^* \otimes M \xrightarrow{\triangleright} M \right). \end{aligned}$$

Since the topology on  $\text{Hom}_{\mathbb{K}}^C(S\mathfrak{g}^*, M)$  is initial w.r.t. the maps  $\text{Hom}_{\mathbb{K}}^C(S\mathfrak{g}^*, M) \rightarrow \text{Hom}_{\mathbb{K}}^C(S^{\leq k}\mathfrak{g}^*, M)$ , it is actually enough to look at the map

$$\begin{aligned} \Theta : \text{Hom}_{\mathbb{K}}^C(S\mathfrak{g}^*, M) & \longrightarrow \text{Hom}_{\mathbb{K}}^C(S^{\leq k}\mathfrak{g}^*, M) \\ s & \longmapsto \left( S^{\leq k}\mathfrak{g}^* \xrightarrow{\Delta} S^{\leq k}\mathfrak{g}^* \otimes S^{\leq k}\mathfrak{g}^* \xrightarrow{S \otimes s} S^{\leq k}\mathfrak{g}^* \otimes M \xrightarrow{\triangleright} M \right). \end{aligned}$$

First we fix  $s$  and check the continuity of  $\Theta s$ . We can write  $\Theta s$  as a composition

$$\Theta s : S^{\leq k}\mathfrak{g}^* \xrightarrow{\Delta} S^{\leq k}\mathfrak{g}^* \otimes S^{\leq k}\mathfrak{g}^* \xrightarrow{S \otimes s} S^{\leq k}\mathfrak{g}^* \otimes s(S^{\leq k}\mathfrak{g}^*) \xrightarrow{\triangleright} M$$

The first two maps are continuous and the third also is because it is continuous as a map  $S^{\leq k}\mathfrak{g}^* \otimes s(S^{\leq k}\mathfrak{g}^*) \xrightarrow{\triangleright} M$  and  $S^{\leq k}\mathfrak{g}^* \otimes s(S^{\leq k}\mathfrak{g}^*) = S^{\leq k}\mathfrak{g}^* \otimes s(S^{\leq k}\mathfrak{g}^*)$  by Claim C.3 ( $s(S^{\leq k}\mathfrak{g}^*)$  is bounded).

Now we check continuity of  $s \mapsto \Theta s$ . Since  $S^{\leq k} \mathfrak{g}^*$  is bounded, we have a basis of neighborhoods of 0 in  $\text{Hom}_{\mathbb{K}}^C(S^{\leq k} \mathfrak{g}^*, M)$ :

$$V_U := \{f : S^{\leq k} \mathfrak{g}^* \rightarrow M \text{ s.t. } \text{Im}(f) \subset U\}$$

indexed by open subspaces  $U \subset_{\text{os}} M$ . Fix one such  $V_U$ . We want to find  $U' \subset_{\text{os}} M$  s.t.

$$s(S^{\leq k} \mathfrak{g}^*) \subset U' \implies (\Theta s)(S^{\leq k} \mathfrak{g}^*) \subset U.$$

For that, it is enough to take  $U' \subset_{\text{os}} M$  satisfying  $(S^{\leq k} \mathfrak{g}^* \triangleright U') \subset U$  which exists by the part a) of Claim C.6.  $\square$

#### APPENDIX E. CATEGORIES OF $\mathbb{K}[[\hbar]]$ -MODULES

We equip  $\mathbb{K}[[\hbar]]$  with the  $\hbar$ -adic topology. This way it becomes an algebra in  $\mathcal{V}^{\text{cpl}}$ .

**Definition E.1.** We denote  $\mathcal{V}_{\mathbb{K}[[\hbar]]}^{\text{top}} := \mathbb{K}[[\hbar]]\text{-Mod}(\mathcal{V}^{\text{top}})$  — the category of topological  $\mathbb{K}[[\hbar]]$ -modules with  $\otimes_{\mathbb{K}[[\hbar]]}$  as a monoidal structure.

For a topological  $\mathbb{K}[[\hbar]]$ -module  $M$  we denote by  $\tilde{M} := \text{compl}_{\hbar} M := \varprojlim_k M/\hbar^k M$  its  $\hbar$ -adic completion. If  $M = \text{compl}_{\hbar} M$  we call it  $\hbar$ -complete.

By  $\mathcal{V}_{\mathbb{K}[[\hbar]]}^{\hbar\text{-cpl}}$  we denote the full subcategory of  $\mathcal{V}_{\mathbb{K}[[\hbar]]}^{\text{top}}$  consisting of  $\hbar$ -complete modules. We equip  $\mathcal{V}_{\mathbb{K}[[\hbar]]}^{\hbar\text{-cpl}}$  with the  $\hbar$ -completed tensor product

$$M \tilde{\otimes}_{\mathbb{K}[[\hbar]]} N := \text{compl}_{\hbar}(M \otimes_{\mathbb{K}[[\hbar]]} N).$$

$\mathcal{V}_{\mathbb{K}[[\hbar]]}^{\text{cpl}}$  will denote the category of complete topological  $\mathbb{K}[[\hbar]]$ -modules. It has a monoidal product

$$M \hat{\otimes}_{\mathbb{K}[[\hbar]]} N := (M \otimes_{\mathbb{K}[[\hbar]]} N)^{\wedge}.$$

One can see  $\text{compl}_{\hbar} : \mathcal{V}_{\mathbb{K}[[\hbar]]}^{\text{top}} \rightarrow \mathcal{V}_{\mathbb{K}[[\hbar]]}^{\hbar\text{-cpl}}$  as the left adjoint functor to the forgetful  $\mathcal{V}_{\mathbb{K}[[\hbar]]}^{\hbar\text{-cpl}} \rightarrow \mathcal{V}_{\mathbb{K}[[\hbar]]}^{\text{top}}$  as a consequence of the following:

**Proposition E.2.** *The natural map  $M \xrightarrow{i} \text{compl}_{\hbar} M$  has the following universal property. If  $N$  is complete and  $f : M \rightarrow N$  is continuous linear, then there is a unique continuous  $\mathbb{K}[[\hbar]]$ -linear map  $\tilde{f} : \text{compl}_{\hbar} M \rightarrow N$  that satisfies  $f = \tilde{f} \circ i$ .*

*Proof.* From the lemma A.2 we see that the map  $M \xrightarrow{i} \text{compl}_{\hbar} M$  has a dense image w.r.t. the  $\hbar$ -adic topology on  $\text{compl}_{\hbar} M$ . Since  $\text{compl}_{\hbar} M$  is Hausdorff in  $\hbar$ -adic topology, this implies that  $\tilde{f}$  is unique if it exists.

The proof of the existence is the same as in the proposition A.6.  $\square$

**Proposition E.3.** *If  $M, N \in \text{ob}(\mathcal{V}_{\mathbb{K}[[\hbar]]}^{\text{top}})$  then*

$$\text{compl}_{\hbar} \left( \text{compl}_{\hbar}(M) \otimes_{\mathbb{K}[[\hbar]]} \text{compl}_{\hbar}(N) \right) = \text{compl}_{\hbar}(M \otimes_{\mathbb{K}[[\hbar]]} N).$$

*In other words,  $\text{compl}_{\hbar} : (\mathcal{V}_{\mathbb{K}[[\hbar]]}^{\text{top}}, \otimes_{\mathbb{K}[[\hbar]]}) \rightarrow (\mathcal{V}_{\mathbb{K}[[\hbar]]}^{\hbar\text{-cpl}}, \tilde{\otimes}_{\mathbb{K}[[\hbar]]})$  is a strong monoidal functor.*

*Proof.* Both sides can be characterized by the same universal property.  $\square$

**Claim E.4.** *Let  $M \in \text{ob}(\mathcal{V}_{\mathbb{K}[[\hbar]]}^{\text{top}})$  be a topological  $\mathbb{K}[[\hbar]]$ -module and  $U \subset M$  an open vector subspace. Then there exists an  $n \in \mathbb{N}$  s.t.  $\hbar^n M \subset U$ .*

*Proof.* The  $\mathbb{K}[[\hbar]]$ -module structure  $\mathbb{K}[[\hbar]] \otimes M \rightarrow M$  is continuous. Now just use the definition of the topology on the tensor product (see the subsection A.2).  $\square$

**Corollary E.5.** *If  $M$  is complete then it is  $\hbar$ -complete.*

*Proof.* Using the claim we have for any fixed  $U$  a map

$$\tilde{M} \rightarrow M/\hbar^k \rightarrow M/U .$$

This defines a canonical map  $\tilde{M} \rightarrow \hat{M}$ . Obviously, the canonical map  $M \rightarrow \hat{M}$  factorizes as  $M \rightarrow \tilde{M} \rightarrow \hat{M}$ . If  $M$  is complete then  $M = \hat{M}$  and so we have

$$(E.1) \quad (M \rightarrow \tilde{M} \rightarrow M) = \text{id}_M .$$

To finish the proof we need to see also

$$(E.2) \quad (\tilde{M} \rightarrow M \rightarrow \tilde{M}) = \text{id}_{\tilde{M}} .$$

Since  $M \rightarrow \tilde{M}$  has a  $\hbar$ -dense image and  $\tilde{M}$  is  $\hbar$ -Hausdorff, it is enough to check (E.2) when both sides are precomposed with  $M \rightarrow \tilde{M}$ . That is, we should see  $(M \rightarrow \tilde{M} \rightarrow M \rightarrow \tilde{M}) = (M \rightarrow \tilde{M})$  which is a consequence of (E.1).  $\square$

**Proposition E.6.** *We have a strong-monoidal functor preserving finite colimits*

$$(\mathcal{V}^{\text{top}}, \otimes) \rightarrow (\mathcal{V}_{\mathbb{K}[[\hbar]]}^{\hbar\text{-cpl}}, \tilde{\otimes}_{\mathbb{K}[[\hbar]]}) : M \mapsto M[[\hbar]] := \text{compl}_{\hbar}(M \otimes \mathbb{K}[[\hbar]]) .$$

*If  $M \in \mathcal{V}^{\text{cpl}}$  then  $M[[\hbar]] \in \mathcal{V}_{\mathbb{K}[[\hbar]]}^{\text{cpl}}$ .*

*Proof.* The first part is clear since our functor is the composition

$$\mathcal{V}^{\text{top}} \xrightarrow{-\otimes \mathbb{K}[[\hbar]]} \mathcal{V}_{\mathbb{K}[[\hbar]]}^{\text{top}} \xrightarrow{\text{compl}_{\hbar}} \mathcal{V}_{\mathbb{K}[[\hbar]]}^{\hbar\text{-cpl}} .$$

and both these functors are strong monoidal (Propositions 6.6 and E.3) and preserve finite colimits (Proposition A.12 and  $\text{compl}_{\hbar}$  is a left adjoint).

To prove the last statement, assume that  $M$  is a complete vector space. We can write

$$M[[\hbar]] = \text{compl}_{\hbar}(M \otimes \mathbb{K}[[\hbar]]) = \varprojlim_k (M \otimes (\mathbb{K}[\hbar]/\hbar^k)) .$$

Since  $\mathbb{K}[\hbar]/\hbar^k$  is finite dimensional, we get  $M[[\hbar]]$  as a limit of complete vector spaces. Consequently  $M[[\hbar]]$  is complete by the proposition A.7.  $\square$

E.1.  $\mathcal{V}_{\mathbb{K}[[\hbar]]}^{\hbar\text{-cpl}}$ -**categories.** If we replace  $\mathbb{K}$ -vector spaces by  $\mathbb{K}[[\hbar]]$ -modules in the definition A.19 we get a notion of a  $\mathcal{V}_{\mathbb{K}[[\hbar]]}^{\hbar\text{-cpl}}$ -category. We now show how to construct  $\mathcal{V}_{\mathbb{K}[[\hbar]]}^{\hbar\text{-cpl}}$ -categories from  $\mathcal{V}^{\text{top}}$ -categories.

Let  $\mathcal{C}$  be a  $\mathcal{V}^{\text{top}}$ -category. We denote by  $\mathcal{C}[[\hbar]]$  the category with the same objects as  $\mathcal{C}$ , with the hom-sets

$$\mathcal{C}[[\hbar]](X, Y) := \left( \mathcal{C}(X, Y) \right) [[\hbar]]$$

and with the obvious composition of morphisms and monoidal structure.

**Proposition E.7.** *If  $\mathcal{C}$  was a  $\mathcal{V}^{\text{top}}$ -category then  $\mathcal{C}[[\hbar]]$  is a  $\mathcal{V}_{\mathbb{K}[[\hbar]]}^{\hbar\text{-cpl}}$ -category.*

*Remark E.8.* If  $\mathcal{C}$  is a preabelian category then  $\mathcal{C}[[\hbar]]$  is not necessarily a preabelian category. This poses a problem if we want to construct the category of  $A$ -modules for a commutative algebra  $A$  in  $\mathcal{C}[[\hbar]]$ . However, we can still form **Free- $A$** ( $\mathcal{C}[[\hbar]]$ ).

**Observation E.9.** *Let  $A$  be a commutative algebra in  $\mathcal{C}$ . Then*

$$\mathbf{Free}\text{-}A(\mathcal{C}[[\hbar]]) = \left(\mathbf{Free}\text{-}A(\mathcal{C})\right)[[\hbar]] .$$

#### REFERENCES

1. V. G. Drinfeld: Quasi-Hopf algebras. (Russian) *Algebra i Analiz* 1 (1989), no. 6, 114–148; translation in *Leningrad Math. J.* 1 (1990), no. 6, 1419–1457.
2. V. G. Drinfeld: On quasitriangular quasi-Hopf algebras and on a group closely connected with  $\text{Gal}(\overline{\mathbb{Q}}/\mathbb{Q})$ . (Russian) *Algebra i Analiz* 2 (1990), no. 4, 149–181; translation in *Leningrad Math. J.* 2 (1991), no. 4, 829–860.
3. B. Enriquez, G. Halbout: Quantization of quasi-Lie bialgebras. *J. Amer. Math. Soc.* 23 (2010), no. 3, 611–653.
4. P. Etingof, D. Kazhdan: Quantization of Lie bialgebras. I. *Selecta Math. (N.S.)* 2 (1996), no. 1, 1–41.
5. Köthe, Gottfried: Topological vector spaces. I. *Die Grundlehren der mathematischen Wissenschaften, Band 159* Springer-Verlag New York Inc., New York 1969.

DEPARTMENT OF MATHEMATICS, UNIVERSITÉ DE GENÈVE, GENEVA, SWITZERLAND; DEPT. OF THEORETICAL PHYSICS, FMFI UK, BRATISLAVA, SLOVAKIA

*E-mail address:* pista.sakalos@gmail.com

DEPARTMENT OF MATHEMATICS, UNIVERSITÉ DE GENÈVE, GENEVA, SWITZERLAND, ON LEAVE FROM DEPT. OF THEORETICAL PHYSICS, FMFI UK, BRATISLAVA, SLOVAKIA

*E-mail address:* pavol.severa@gmail.com