



Chapitre d'actes

2014

Published version

Open Access

This is the published version of the publication, made available in accordance with the publisher's policy.

In situ monitoring results of an existing geothermal heat pump for the
heating of a retrofitted office building in Geneva

Mermoud, Floriane; Hollmuller, Pierre; Pampaloni, Eric; De Sousa Fraga, Carolina; Lachal, Bernard Marie

How to cite

MERMOUD, Floriane et al. In situ monitoring results of an existing geothermal heat pump for the heating of a retrofitted office building in Geneva. In: 11th International Energy Agency Heat Pump Conference. Montreal (Canada). [s.l.] : [s.n.], 2014.

This publication URL: <https://archive-ouverte.unige.ch/unige:37095>

IN SITU MONITORING RESULTS OF AN EXISTING GEOTHERMAL HEAT PUMP FOR THE HEATING OF A RETROFITTED OFFICE BUILDING IN GENEVA

Floriane Mermoud, lecturer, Institut des Sciences de l'Environnement & Section des Sciences de la Terre et de l'Environnement, Institut Forel, University of Geneva, Batelle Bat. D, 7 route de Drize, 1227 Carouge, Switzerland;

Pierre Hollmuller, Eric Pampaloni, Carolina Fraga, Bernard Lachal, Institut des Sciences de l'Environnement & Section des Sciences de la Terre et de l'Environnement, Institut Forel, University of Geneva, Batelle Bat. D, 7 route de Drize, 1227 Carouge, Switzerland;

Abstract: An office building of 2'200 m² in Geneva (Switzerland) was renovated in 2007 according to the low-energy-consumption standards of the Minergie label. Along with the renovation, a new floor (1'450 m²) was added. The oil boiler was replaced by two 120 kWth heat pumps coupled with 2'700 m of geothermal boreholes.

This article presents the results of a 2-year energy monitoring (Oct. 2010-Oct. 2012) of the overall system. Detailed instrumentation has been implemented in order to evaluate its performance.

The results show that the heating demand has been divided by 4, decreasing from 108 to 27 kWh/m²/yr: the envelope of the building is now very efficient. The electricity consumption of the heating system is less than 10 kWh/m²/yr for 2011-2012, which is very low. The annual system SPF is 3. This value is modest taking into account that: (1) the heat source is of good quality (geothermal boreholes) (2) no domestic hot water (i.e. high temperature heat) has to be produced (tertiary building). This low performance can partly be explained by the fact that the heat pump works at around 10K higher than required by the distribution, due to the hydraulic configuration of the system.

Key Words: geothermal heat pump, renovation, in situ-monitoring, system analysis, tertiary building

1 INTRODUCTION

Over the past decades, the global warming and the depletion of fossil resources induced a growing interest in heat pump (HP) systems. A recurring question is to find heat sources that lead to good performances: for this purpose geothermal boreholes are one of the most interesting heat sources, and they are widely used nowadays.

When dealing with performances of HP systems, it is essential to properly specify the boundaries of calculation, especially if a comparison between different installations is aimed. An attempt to harmonize the definitions was performed in the framework of the European project SEPemo-Build¹ (SEasonal PEformance factor and MOnitoring for heat pump systems in the building sector). The conventions adopted in the following are inspired from it (Zotl et al. 2012), but slightly adapted to our application:

- The notion of "Coefficient of Performance" (COP) refers to "instantaneous" performance (ratio of produced thermal power to consumed electric power).
- The annual performance is characterised by the "Seasonal Performance Factor" (SPF).

¹ <http://www.sepemo.eu/>

Several indicators will be mentioned, depending on the considered boundaries (NB: all are annual values):

- SPF1: HP only
SPF1 = Heat produced by the HP / Electricity consumed by the HP (1)
- SPF2: HP and its conveying devices (electric pumps)
SPF2 = Heat produced by the HP / Electricity consumed by the HP and the conveying devices (2)
- SPF3: system (HP, back-up system, building), excluding distribution pump
SPF3 = Heat demand of the building / Electricity consumed by the HP, the conveying devices and the back-up system (3)
- SPF4 : system, including distribution pump
SPF4 = Heat demand of the building / Electricity consumed by the HP, the conveying devices (including distribution pump) and the back-up system (4)

Several authors measured the performance of geothermal HPs in real operation, among which can be mentioned Erb et al. (2004) and Miara et al. (2010), which refer to individual housing. Erb et al. (2004) studied 236 HP systems in operation in Switzerland within new and renovated buildings. 94 of them were geothermal HPs, for which the average SPF4 is 3.5. Miara et al. (2010) studied 83 HP systems installed in Germany during 3 years of operation. The 56 geothermal HPs presented a SPF3 between 3.1 and 5.2 (average at 3.9), an average SPF4 of 3.8 and an average SPF1 of 4.2. 2 systems included solar recharging of the boreholes, which enabled to boost the SPF3 up to 4.9 and 6.

Other authors studied diverse configurations of geothermal HPs coupled with solar collectors for summer recharge. Wang et al. (2010) reported a SPF4 of 6.1 on their installation, which is only devoted to space heating (no domestic hot water (DHW) production). Trillat-Berdal et al. studied a similar system (for space heating only) described in (Trillat-Berdal et al. 2007). They only mentioned monthly SPFs in their article (Trillat-Berdal et al. 2006), ranging between 3 and 3.5 for SPF4 and 3.5 and 4 for SPF1. The installation studied by Loose et al. (2012) includes a heat storage in addition to the boreholes and solar collectors. It presents a SPF3 between 5 and 5.3 and a SPF1 of 3.7 over 3 years of operation. Finally, Bertram et al. (2012) analysed a system coupling a geothermal HP with PVT hybrid collectors and reached a SPF4 of 4.2, which would drop to 3.8 without solar recharging according to the simulation results.

All these studies refer to small installations for individual housing, and very few material is available for larger installations, in operation in collective housing or in tertiary buildings. The results presented here concern a large tertiary building (~4'000 m²), renovated in 2007 and equipped with two geothermal HPs.

2 DESCRIPTION OF THE PROJECT

2.1 Building

The case study is a tertiary building dating from the 60s, located in an industrial zone of Geneva. Before its renovation, it was heated thanks to an oil boiler and the heated surface was 2'200 m².

2.2 Renovation concept

In 2007, the owner began a complete retrofit of its building, including:

- Energy renovation of the envelope in order to achieve the requirements of the Minergie standard (Swiss low-energy building label): insulation of the entire building, single glazing replaced by double glazing.
- Rise of an additional floor above the existing building (1'450 heated m² with highly efficient thermal envelope). NB: in the following, the existing part of the building is named "old building" and the additional floor "new building".

Figure 1 shows the building before and after its transformation.



Figure 1: Studied building before and after renovation (source: P. Previdoli)

2.3 Energy concept

The building renovation was the opportunity to implement a new energy concept based on renewable energy sources. The new technical facilities include:

- 2 geothermal heat pumps for the heating of the whole building (with possibility of cooling).
- Dual flow ventilation (DFV) for the new building only.
- The heat distribution of the old building has not been modified and a separate thermal circuit was added for the new building. The heat emission is performed thanks to cast iron radiators in both cases.

The heating system consists of 2 HPs (120 kW each), coupled to 11 geothermal boreholes as their heat source (244 m each, 2'684 m in total). Each HP presents 2 compressors so that 4 levels of capacity are available. The HPs are in series with a 2'000 L storage tank (i.e. the HPs do not provide the heat directly to the distribution circuits). Figure 2 presents a simplified diagram of the heating system.

One of the HPs is reversible to be able to provide cooling during summer. In order to avoid freezing in the downstream pipes when operating in cooling mode, an intermediate circuit with brine was implemented, implying an additional heat exchanger between the HP and the tank (see Figure 2).

2.4 Monitoring concept

Detailed monitoring was implemented in order to understand how the system works (e.g. temperature levels) and to quantify the energy flows in the system as well as its energy performance. It consisted of 32 sensors (21 thermocouples, 5 heat and 3 electric meters, 1 anemometer, 1 thermo-hygrometer for outdoor air), partly represented on Figure 2. The data was collected thanks to a Campbell Scientific CR3000 datalogger, which stored every 5 minutes an average or sum of the values read every 5 seconds. The monitoring started in October 2010 for a period of two years (until September 2012).

NB: only the monitoring results concerning the heating system are reported in this article (excluding results concerning cooling mode and ventilation). Economic aspects have also been studied in addition to experimental results but they are not presented here.

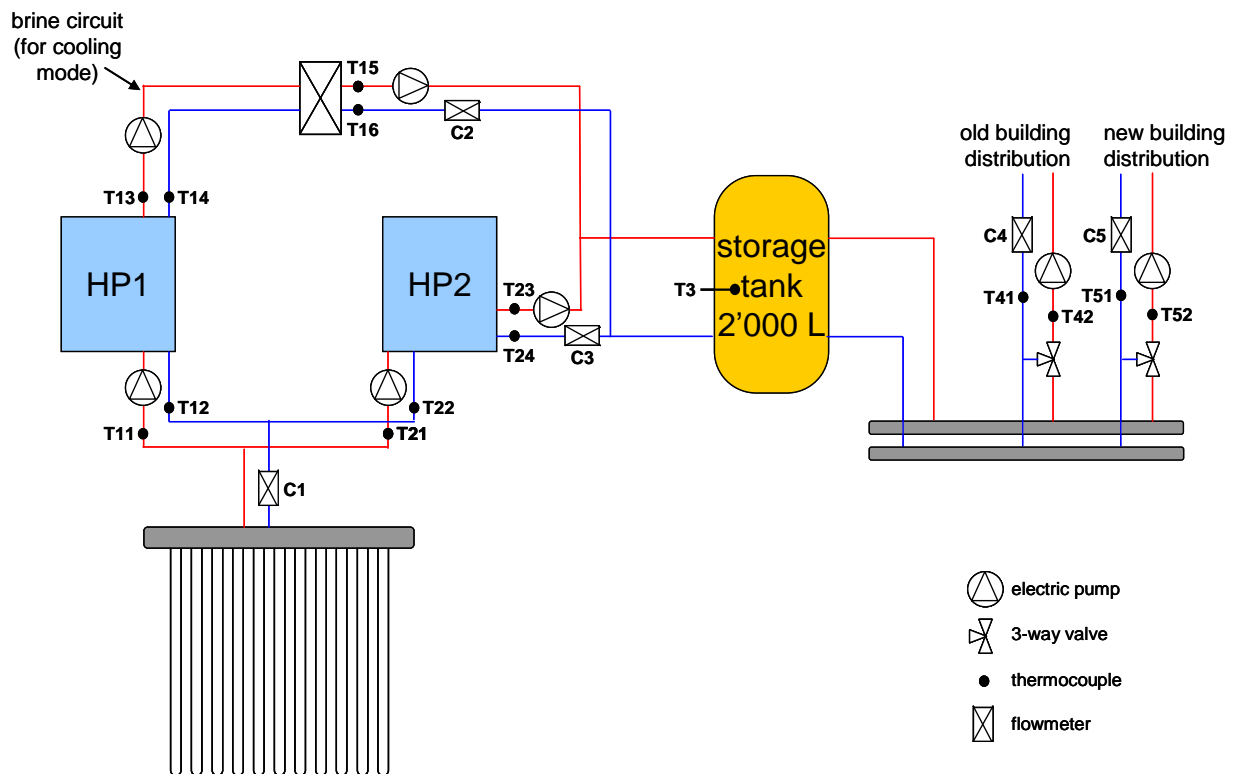

Figure 2: Simplified heating system diagram

3 RESULTS AND DISCUSSION

All the results presented below are based on the energy monitoring and refer to the winter 2011-2012 period (Oct.-Apr.). NB: the HP is switched off during summer.

3.1 Building demand

The case study is a tertiary building, thus the heat demand is only devoted to space heating (no DHW production). The renovation of the building envelope enabled a reduction of the heat demand by a factor 4 (from 108 to 27 kWh/m²/yr).

Figure 3 presents the heat demand (W/m²) vs. outdoor temperature for the old building, the new building and the entire building. The heat demand provided by the radiators is 9 W/m² when the outdoor temperature is 0°C. The heat load of the new building is higher than that of the old building (measured on each thermal circuit), because the old building presents a better form factor than the new one, with less surface exposed to heat losses with outdoor air (two floors for the old building and one floor plus the roof for the new building). NB: these values do not include the heating contribution from the DFV (only radiators).

The new building envelope is excellent since the heat demand after renovation is similar to that observed in recent buildings at Minergie standard: as an example, the space heating demand in a residential Minergie building in Geneva built in 2004 is 25 kWh/m²/yr, with a heat load of 10 W/m² at 0°C (Zraggen 2010). As a comparison, another residential building in Geneva was renovated in 2008 in order to achieve the Minergie requirements, and it shows a space heating demand after renovation of 73 kWh/m²/yr with a heat load of 22 W/m² at 0°C (Mermoud et al. 2012).

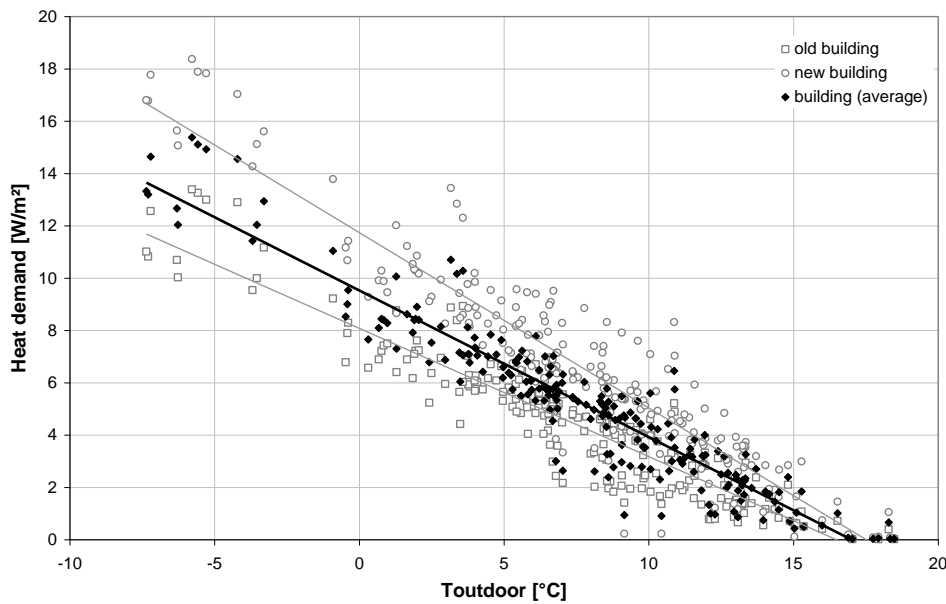

Figure 3: Heat demand vs. outdoor temperature (Oct. 2011-Apr. 2012, daily values) for the old building, the new building and the entire building

Figure 4 shows the distribution and return temperatures for the old building thermal circuit (the operation temperatures are very similar for the new building).

The distribution temperature is 45°C when the outdoor temperature is -10°C, and 25°C when the outdoor temperature is 18°C: these values are acceptable taking into account that heat is emitted thanks to classic radiators. A night setback lowers the distribution temperature by 10K between 10 p.m. and 5 a.m.

The difference between distribution and return temperature is also presented on Figure 4. It is very low: less than 5K and mainly between 2 and 4K (whereas it could be higher than 10K), reflecting high distribution flows. An attempt to lower the rates was experimented but it led to “cold radiators” in several rooms: a hydraulic balancing should be performed before lowering the flows in the distribution circuit.

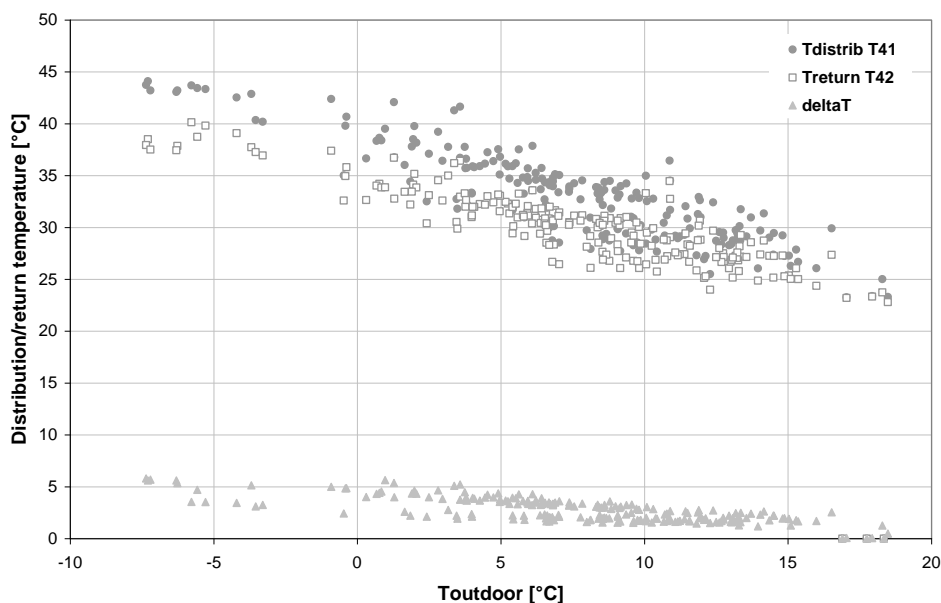

Figure 4: Distribution and return temperatures as well as temperature difference for the old building (Oct. 2011-Apr. 2012, daily values)

3.2 Heat pump characterization

3.2.1 Control

The HPs are used for the storage charge (the heat is then provided to the distribution circuits by the tank). They are activated when the temperature in the upper part of the storage tank drops below the set point and stop when the temperature in the lower part rises above the set point. The set point depends on the outdoor temperature: 45°C when the outdoor temperature is -10°C and 20°C when the outdoor temperature is 20°C (set in accordance with distribution temperatures).

The two HPs can operate separately or simultaneously and with one or two compressors, depending on the heat demand.

3.2.2 Sizing

During winter 2011-2012, HP1 operated 28% of the time and HP2 only 2%, providing respectively 95 and 5% of the heat. The heating system is widely oversized, since HP1 alone may cover all the energy needs. Averaged over the time of operation, the HP1 load was about half of its maximum capacity during winter 2011-2012.

The maximum power taken from the geothermal boreholes was about 30 W/m, and the average value (during operation) is around 15 W/m. The value of 30 W/m is low comparing with the recommended value of 50 W/m for an optimal sizing in Switzerland: it has to be noticed that the boreholes were sized for the two HPs operating together, but in practice the low energy needs do not require a so large capacity.

3.2.3 Temperature levels

On this plant, the temperature of the HP production (condenser output) cannot be controlled directly. It only depends on the temperature at the condenser input, with a fixed temperature increase of 7-8K (one compressor), respectively 14-15K (two compressors).

Figure 5 illustrates the temperature levels (HP1) observed in Nov.-Dec. 2011.

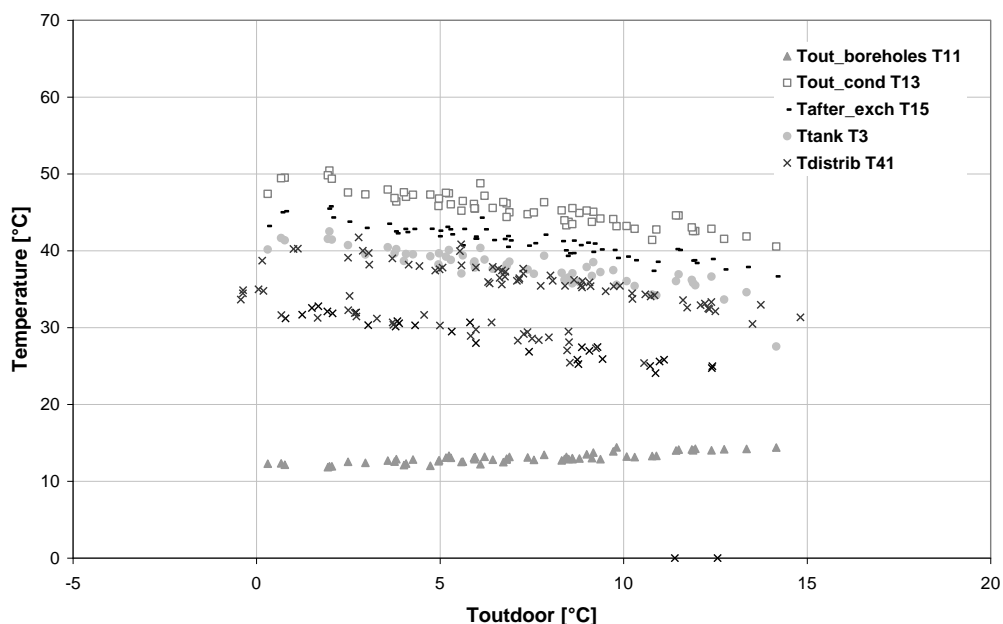

Figure 5: Boreholes output temperature, HP1 condenser output temperature, temperature after heat exchanger, storage tank temperature, old building distribution temperature (Nov.-Dec. 2011, daily values*)

*for distribution temperatures, day and night (with setback) were separated for the calculation of daily values

For HP1, the evaporator input (=boreholes output) temperature is about 12-13°C, due to the oversizing of the heating system and hence of the boreholes. Heat delivered at condenser output is in the range 40 to 55°C (depending on the outdoor temperature), followed by a 5K temperature drop in the heat exchanger, and another 5K difference with the average temperature in the tank. Finally, the heat is distributed to the building at the tank temperature (with a 10K night setback). Hence, the condenser output temperature is around 10K higher than the temperature requirement for the building, which ends up penalizing the HP performance. This is all the more annoying as the brine/water heat exchanger after HP1, which was set up for cooling purposes, turns out to be useless. As a matter of fact, cooling of the building (only for a few offices) is done by way of chilled ceilings i.e at a temperature of about 15°C, far above any icing problem.

3.2.4 Typical winter day

Figure 6 illustrates the operation of the heating system during a typical winter day (18/02/12).

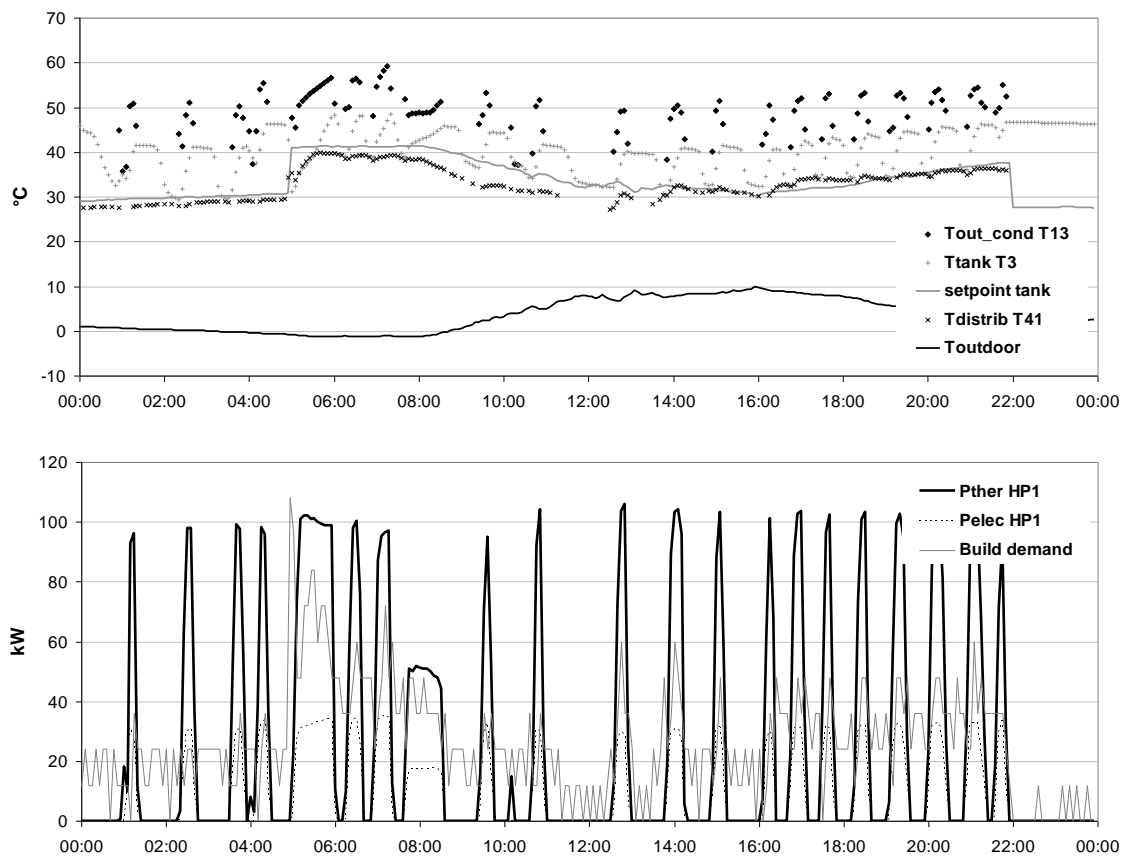

Figure 6: Temperature levels and load observed during 18th Feb. 2012 (5 min values)

During this specific day, the outdoor temperature is around 0°C during the night and increases until 10°C during the day. 21 cycles of operation of 10-20 min are observed, which is rather short. It shows that the storage volume is too small: (1) compared to the HP capacity (2) compared to the heat demand. Under these conditions, the tank should be considered more as a buffer than as a storage. It should also be highlighted that so many cycles of operation per day is bad for the durability of the equipment. On that day, the HP mainly operates at full capacity with 2 compressors, whereas longer cycles would be observed with only one compressor. A question that can be raised is if inverter HPs (which can adapt their capacity to the load) may be justified in systems of that size.

The set point temperature in the storage tank is close to the measured distribution temperature, but the measured temperature in the tank is a bit higher than the set point. The night setback for the storage tank and the distribution is clearly visible.

3.3 Performance

3.3.1. Coefficient of performance

The HP performance is usually defined thanks to the Coefficient of Performance (COP_{HP}) and the Efficiency (Eff_{HP}):

$$COP_{HP} = \text{HP Heat output} / \text{HP electricity consumption} \tag{5}$$

$$Eff_{HP} = COP_{HP} / \text{Carnot Cycle limit} \tag{6}$$

where Carnot Cycle limit = $T_{out_cond} / (T_{out_cond} - T_{in_evap})$, T in K

Figure 7 shows COP and Efficiency of HP1 vs. temperature difference between HP condenser output and evaporator input for Nov.-Dec. 2011 (5 min values). Values with one or two compressors in operation are separated. Manufacturer data (for operation with 2 compressors) is also represented.

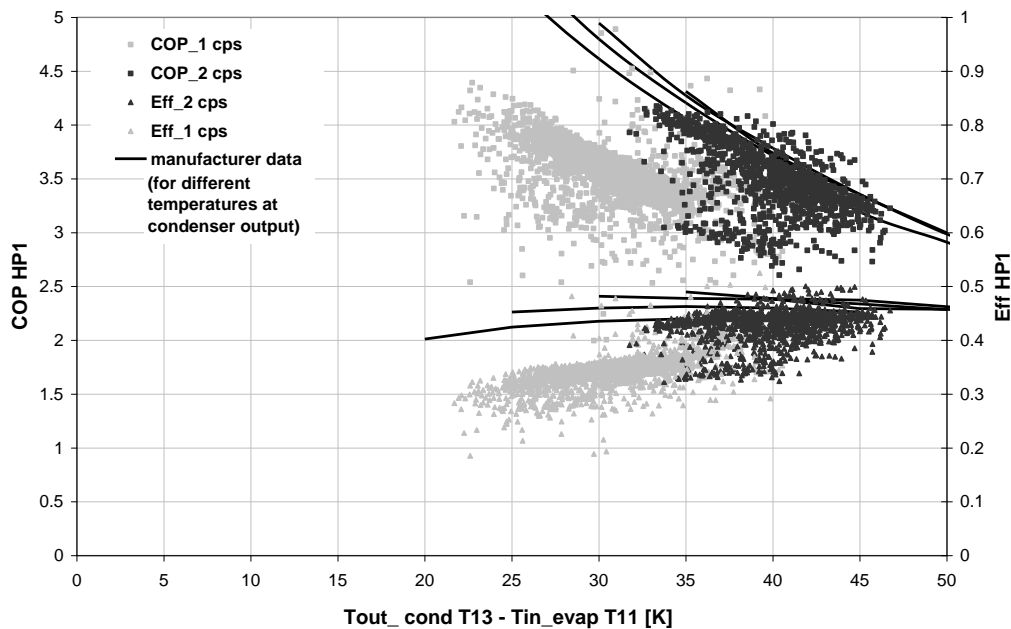

Figure 7: HP1 COP and Efficiency vs. temperature difference between HP condenser output and evaporator input for Nov.-Dec. 2011 (5 min values)

As expected, COP_{HP} decreases when the temperature difference between heat source and sink (ΔT) increases (approx. -0.8 point of COP per +10K of ΔT). During Nov.-Dec. 2011, ΔT mainly varied between 25 and 45K. The discrimination between the two operation modes (1 or 2 compressors) is clear. For the same ΔT , COP is higher when 2 compressors operate (+0.7 point of COP). COP with 1 compressor varies between 4.2 and 3.4 for a ΔT between 25 and 35K, whereas COP with 2 compressors varies between 4.1 and 3.3 for a ΔT between 35 and 45K. The HP efficiency increases with ΔT , and it is lower with 1 compressor (0.3-0.4) than with 2 compressors (0.4-0.45): these values are usual for HPs available on the market. The dispersion of the values is important because 5 min values were used (due to transient states). Hourly values could not be used in this case because the typical duration of a cycle is a few tens of minutes. Manufacturer data, provided only for the 2-compressor operation, are slightly higher than the measured values, which is not surprising since the conditions of operation are different (e.g. the fluid in the condenser circuit is brine and not water as in the standard tests).

3.3.2. Seasonal Performance Factors

Heat Pump 1

As defined in chapter 1, two distinct SPF_s can be calculated for the HP: SPF₁, which only takes into account the electricity consumption of the HP and SPF₂, which includes the electricity consumed by the conveying devices (pumps).

Table 1 presents the energy flows concerning HP1 for winter 2011-2012, detailing the consumption of the boreholes side pump (2'500 W), and the condenser side pumps (2x120 W).

Table 1: Energy flows and SPF for HP1 during winter 2011-2012

		Winter 2011-2012 (Oct.-Apr.)
Heat produced by HP1	kWh/m ²	26.1
Total HP1 electricity consumption	kWh/m ²	8.5
HP	kWh/m ²	7.56
Upstream pump (boreholes side)	kWh/m ²	0.86
Downstream pump (condenser side)	kWh/m ²	0.09
%pumps		11%
SPF1 HP1		3.5
SPF2 HP1		3.1

SPF₁ is 3.5 for winter 2011-2012, SPF₂ drops to 3.1. The consumption of the electric pumps is 11% of the total electricity consumption for HP1: 10% for the upstream pump (larger because of the important length of the boreholes) and 1% for the downstream pump.

System

Table 2 shows the energy flows in the whole system (HP1, HP2, building) for winter 2011-2012.

Table 2: Energy flows and SPF for the system during winter 2011-2012

		Winter 2011-2012 (Oct.-Apr.)
Building heat demand	kWh/m ²	26.3
HP1		
Produced heat	kWh/m ²	26.1
Electricity consumption (including pumps)	kWh/m ²	8.5
SPF2		3.1
HP2		
Produced heat	kWh/m ²	0.3
Electricity consumption (including pumps)	kWh/m ²	0.1
SPF2		3.0
Electricity for distribution pumps	kWh/m ²	0.3
Total electricity consumption	kWh/m ²	8.9
SPF3		3.1
SPF4		3.0

SPF₃ (as defined in chapter 1) is 3.1 for winter 2011-2012. When including the electricity consumption of the distribution pumps (0.3 kWh/m² or 3% of the total electricity consumption), SPF₄ drops to 3.0.

This value is modest considering the quality of the heat source (>10°C all year, because of the oversizing of the geothermal boreholes) and the fact that the heat demand is restricted to space heating, thus at middle temperatures. For individual applications (including DHW

production), Erb et al. (2004) reported a SPF4 of 3.5 (average on 94 installations) and Miara et al. (2010) a SPF4 of 3.8 (average on 56 installations): the value of 3.0 measured here is lower than that observed for smaller systems, whereas no DHW (=at high temperature) has to be produced in our case. It has to be noticed that the potential for substantial improvements is minor, since many optimisations have already been implemented during winter 2010-2011: the system performance will probably not increase much in the coming years.

Regardless the quality of the machine, the performance of a HP system mainly depends on the temperature difference between heat source and sink. The common performance of the studied system can be explained by the fact that the HP produces heat at higher temperature (about 10K) than required by the distribution, because of three main factors:

- The presence of the heat exchanger within the condenser circuit implies a temperature drop of 5K, which requires the HP to produce warmer to reach the set point in the tank.
- The hydraulic configuration of the system forces the fluid to go through the storage tank before going to the distribution and also to return to the HP evaporator. This implies a mixing inside the tank: the return water warms up with the water in the tank before arriving at the HP evaporator.
- High return temperatures from the distribution due to high flows in the circuits: as the temperature difference in the condenser is constant (see 3.2.3), the more the input temperature is high, the more the output temperature is high and the system performance is low. Lower return temperatures (reached by lowering the distribution flows) would improve the system performance but a hydraulic balance of the whole circuit has to be established first.

However, even if the performance is lower than expected, an important point that can be noted is the reliability of the system: very few failures and no breakdown were observed during the monitoring period.

3.4 Discussion

This experience highlights the importance of the design choices, especially in the hydraulic architecture of the system:

- Storage tank in series with the HP: no possibility for direct distribution (i.e. without passing through the tank), with a temperature in the tank higher than required by the distribution.
- Presence of a heat exchanger on the condenser side (intermediate circuit for cooling mode): induces a temperature drop.

This configuration impacts the operation and performance of the system during its whole life, which would not be the case for a conventional system (gas or oil boiler), less affected by the temperature levels.

An adequate sizing is also very important when dealing with HP systems: (1) for technical reasons; as seen in 3.2.4, oversizing of the HP and/or undersizing of the storage tank lead to a large number of short cycles of operation, which risks to early damage the HP (2) for economic reasons, since the investment costs are important in the case of HP systems, and highly depend on the capacity. This is a major difference with conventional systems, for which oversizing the boiler does not strongly impact the operation of the system neither the heat price (since the fuel price holds the largest share).

This work also draws attention to the necessity for HP systems of a careful operation and monitoring in order to ensure high performance: a HP system will probably operate even with default settings, but it will clearly not be optimised. However, it should be noticed that the control possibilities of HP systems are often restricted by the manufacturers (only certain settings can be modified by the user for security reasons).

Another point that can be raised is that presently, when use is made of HP systems, a lot of care is taken to the heat source side (basically to increase its temperature), but very little to the heat sink side (attempt to decrease its temperature), whereas the impact on the

performance is “symmetrical” (i.e. decrease the sink temperature by 1K is equivalent to increase the source temperature by 1K) and the cost is generally lower. Thereby, the optimisation of the building distribution circuit in terms of temperature and flows is usually neglected while it is highly profitable to the HP system. Indeed, distribution temperatures and flows in heating systems are often higher than necessary and could be decreased since the radiators are generally oversized. However, it requires a hydraulic balance in the circuit to avoid some radiators to be cold. For all these points, HP systems are very different from conventional boilers and they should never be considered as such (neither in the design nor in the operation phase).

Returning to the studied system, even if its performance is modest, the electricity consumption remains below 10 kWh/m²/yr (which is low for Switzerland) thanks to the excellent performance of the new thermal envelope. The impact of a potential optimisation of the system SPF, e.g. from 3 to 4, would only generate a reduction in the electricity consumption of 2 kWh/m²/yr. Thus for existing buildings with high heat demand, the optimisation of the system performance is essential, but for new or strongly renovated buildings with low heat demand, the most important issue is probably the cost optimisation, which can imply compromises on technical aspects (e.g. efforts focused on the sink side rather than on the source side).

4 CONCLUSION

An existing tertiary building in Geneva, expanded and renovated in 2007 (~4'000 heated m²), was equipped with two geothermal heat pumps for space heating. The technical facilities have been fully instrumented during 2 years in order to monitor their performance.

First of all, the building heat demand reaches a very low value after renovation (27 kWh/m²/yr), similar to that observed in new buildings at Minergie standard. Concerning the heating system, it should be emphasized that it is very reliable, since no breakdown and very few failures were observed during the monitoring period. The installations are clearly oversized (factor 2) since most of the time one heat pump alone is able to cover the energy needs of the building. This results in high evaporator input temperatures (>10°C all year), since the boreholes were sized for two heat pumps operating together.

The system SPF was 3 during year 2011-2012, which is a modest performance considering (1) the quality of the heat source (2) the fact that the heat demand is only space heating (no domestic hot water), thus at lower temperature. This can partly be explained by the fact that the heat pump operates at around 10K higher than required by the distribution, due to the hydraulic configuration of the system (storage tank in series with the heat pump and presence of an unnecessary heat exchanger on the condenser side). However, the electricity consumption of the system remains low (<10 kWh/m²/yr) since the building demand is low. The share of the conveying devices is estimated at 11% (mainly for the electric pump on boreholes side), and the heat pump SPF raises to 3.5 if the electricity for the pumps is not taken into account.

Concerning the future issues of heat pump systems, as technologies can be considered mature, no major enhancement in their performance can be expected; however, the integration of heat pumps in the whole energy system needs further improvements as it affects the operation of the system throughout its life. Especially, best practices in design (hydraulic architecture, sizing) and operation (control of temperature levels, in particular on heat sink side (building distribution)) should be better disseminated. Moreover, the issue is different for buildings presenting a high heat demand (existing) or a low heat demand (new or renovated): in the first case, the technical optimisation is essential to decrease the electricity consumption, but in the second case, as the electricity consumption is already low, economical optimisation is probably a more important stake to avoid spending a lot of money to produce little heat.

5 ACKNOWLEDGEMENTS

We are grateful to Paul Previdoli (owner of the studied building), to Tech Building (in charge of the operation of the system) and to Groupe H (in charge of the building transformation) for their technical support to this study. This work was funded by "Office cantonal de l'énergie de l'Etat de Genève" (OCEN).

6 REFERENCES

Bertram, E., Glembin, J. and Rockendorf, G. 2012. "Unglazed PVT collectors as additional heat source in heat pump systems with borehole heat exchanger", *Energy Procedia*, 30(0), pp. 414-423.

Erb, M., Hubacher, P. and Ehrbar, M. 2004. "Feldanalyse von Wärmepumpenanlagen FAWA 1996-2003 - Final report", 100 p.

Loose, A., Drück, H., Hanke, N. and Thole, F. 2012. "Field test for performance monitoring of combined solar thermal and heat pump systems", ISES Solar World Congress, Kassel (Germany), 12 p.

Mermoud, F., Khoury, J. and Lachal, B.M. 2012. "Suivi énergétique du bâtiment 40-42 de l'avenue du Gros-Chêne à Onex (GE), rénové selon le standard MINERGIE - Aspects techniques et économiques", University of Geneva, 137 p. <http://archive-ouverte.unige.ch/unige:23005>.

Miara, M., Danny, G., Kramer, T., Oltersdorf, T. and Wapler, J. 2010. "Wärmepumpen Effizienz – Messtechnische Untersuchung von Wärmepumpenanlagen zur Analyse und Bewertung der Effizienz im realen Betrieb", 154 p.

Trillat-Berdal, V., Souyri, B. and Fraisse, G. 2006. "Experimental study of a ground-coupled heat pump combined with thermal solar collectors", *Energy and Buildings*, 38(12), pp. 1477-1484.

Trillat-Berdal, V., Souyri, B. and Achard, G. 2007. "Coupling of geothermal heat pumps with thermal solar collectors", *Applied Thermal Engineering*, 27(10), pp. 1750-1755.

Wang, X., Zheng, M., Zhang, W., Zhang, S. and Yang, T. 2010. "Experimental study of a solar-assisted ground-coupled heat pump system with solar seasonal thermal storage in severe cold areas", *Energy and Buildings*, 42(11), pp. 2104-2110.

Zraggen, J.-M. 2010. "Bâtiments résidentiels locatifs à haute performance énergétique : objectifs et réalités", University of Geneva, 177 p.

Zottl, A., Nordman, R., Coevoet, M., Riviere, P., Miara, M., Benou, A. and Riederer, P. 2012 "SEPOMO-Build Project: Concept for evaluation of SPF - A defined methodology for calculation of the seasonal performance factor and a definition which devices of the system have to be included in this calculation. Heat pumps with hydronic heating systems", Intelligent Energy Europe, 18 p.